

The right choice for the ultimate yield!

LS ELECTRIC strives to maximize your profits in gratitude for choosing us as your partner.

AC Variable Speed Drive

LSLV-H100 series

User's Manual

0.75-18.5kW [200V] 0.75-500kW [400V]

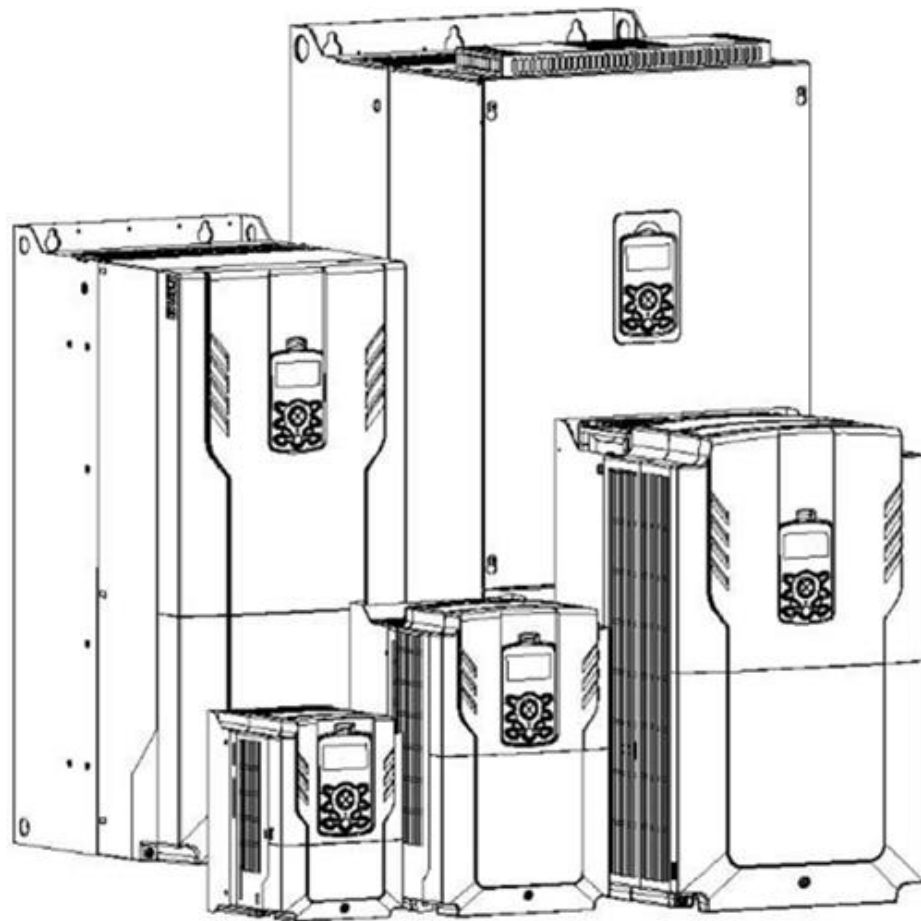

Safety Instructions

- Read this manual carefully before installing, wiring, operating, servicing or inspecting this equipment.
- Keep this manual within easy reach for quick reference.

LS[→]**ELECTRIC**

This operation manual is intended for users with basic knowledge of electricity and electric devices.

* LSLV-H100 is the official name for the H100 series inverters.

* The H100 series software may be updated without prior notice for better performance. To check the latest software, visit our website at <http://www.lselectric.co.kr>.

Safety Information

Read and follow all safety instructions in this manual precisely to avoid unsafe operating conditions, property damage, personal injury, or death.

Safety symbols in this manual

Danger

Indicates an imminently hazardous situation which, if not avoided, will result in severe injury or death.

Warning

Indicates a potentially hazardous situation which, if not avoided, could result in injury or death.

Caution

Indicates a potentially hazardous situation that, if not avoided, could result in minor injury or property damage.

Safety information

Danger

- Do not open the cover of the equipment while it is on or operating. Likewise, do not operate the inverter while the cover is open. Exposure of high voltage terminals or charging area to the external environment may result in an electric shock. Do not remove any covers or touch the internal circuit boards (PCBs) or electrical contacts on the product when the power is on or during operation. Doing so may result in serious injury, death, or serious property damage.
- Do not open the cover of the equipment even when the power supply to the inverter has been turned off unless it is necessary for maintenance or regular inspection. Opening the cover may result in an electric shock even when the power supply is off.
- The equipment may hold charge long after the power supply has been turned off. Use a multi-meter to make sure that there is no voltage before working on the inverter, motor or motor cable.
- Supply earthing system: TT, TN, not suitable for corner-earthed systems

Warning

- This equipment must be grounded for safe and proper operation.
- Do not supply power to a faulty inverter. If you find that the inverter is faulty, disconnect the power supply and have the inverter professionally repaired.
- The inverter becomes hot during operation. Avoid touching the inverter until it has cooled to avoid burns.

- Do not allow foreign objects, such as screws, metal chips, debris, water, or oil to get inside the inverter. Allowing foreign objects inside the inverter may cause the inverter to malfunction or result in a fire.
- Do not operate the inverter with wet hands. Doing so may result in electric shock.

⚠ Caution

- Do not modify the interior workings of the inverter. Doing so will void the warranty.
- The inverter is designed for 3-phase motor operation. Do not use the inverter to operate a single phase motor.
- Do not place heavy objects on top of electric cables. Doing so may damage the cable and result in an electric shock.

Note

Maximum allowed prospective short-circuit current at the input power connection is defined in IEC 60439-1 as 100 kA. LSLV-H100 is suitable for use in a circuit capable of delivering not more than 100kA RMS at the drive's maximum rated voltage, depending on the selected MCCB. RMS symmetrical amperes for recommended MCCB are the following table.

Remarque

Le courant maximum de court-circuit présumé autorisé au connecteur d'alimentation électrique est défini dans la norme IEC 60439-1 comme égal à 100 kA. Selon le MCCB sélectionné, la série LSLV-H100 peut être utilisée sur des circuits pouvant fournir un courant RMS symétrique de 100 kA maximum en ampères à la tension nominale maximale du variateur. Le tableau suivant indique le MCCB recommandé selon le courant RMS symétrique en ampères.

| Working Voltage | UTE100 (E/N) | UTS150 (N/H/L) | UTS250 (N/H/L) | UTS400 (N/H/L) |
|-----------------|--------------|----------------|----------------|----------------|
| 240V(50/60Hz) | 50/65kA | 65/100/150kA | 65/100/150kA | 65/100/150kA |
| 480V(50/60Hz) | 25/35kA | 35/65/100kA | 35/65/100kA | 35/65/100kA |

| Working Voltage | ABS33c | ABS53c | ABS63c | ABS103c | ABS203c | ABS403c |
|-----------------|--------|--------|--------|---------|---------|---------|
| 240V(50/60Hz) | 30kA | 35kA | 35kA | 85kA | 85kA | 75kA |
| 480V(50/60Hz) | 7.5kA | 10kA | 10kA | 26kA | 26kA | 35kA |

Quick Reference Table

The following table contains situations frequently encountered by users while working with inverters. Refer to the typical and practical situations in the table to quickly and easily locate answers to your questions.

| Situation | Reference |
|---|-------------------------------------|
| I want to configure the inverter to start operating as soon as the power source is applied. | <u>p.17</u> |
| I want to configure the motor's parameters. | <u>p.210</u> |
| Something seems to be wrong with the inverter or the motor. | <u>p.330, p.528</u> |
| What is auto tuning? | <u>p.210</u> |
| What are the recommended wiring lengths? | <u>p.40</u> |
| The motor is too noisy. | <u>p.240</u> |
| I want to apply PID control on my system. | <u>p.158</u> |
| What are the factory default settings for P1–P7 multi-function terminals? | <u>p.38</u> |
| I want to view all of the parameters I have modified. | <u>p.249</u> |
| I want to review recent fault trip and warning histories. | <u>p.58</u> |
| I want to change the inverter's operation frequency using a potentiometer. | <u>p.88</u> |
| I want to install a frequency meter using an analog terminal. | <u>p.38</u> |
| I want to display the supply current to motor. | <u>p.54</u> |
| I want to operate the inverter using a multi-step speed configuration. | <u>p.101</u> |
| The motor runs too hot. | <u>p.307</u> |
| The inverter is too hot. | <u>p.320</u> |
| The cooling fan does not work. | <u>p.535</u> |
| I want to change the items that are monitored on the keypad. | <u>p.302</u> |
| I want to display the supply current to motor. | <u>p.302</u> |

Table of Contents

| | | |
|----------|---|-----------|
| 1 | Preparing the Installation..... | 1 |
| 1.1 | Product Identification..... | 1 |
| 1.2 | Part Names..... | 3 |
| 1.3 | Installation Considerations..... | 10 |
| 1.4 | Selecting and Preparing a Site for Installation | 11 |
| 1.5 | Cable Selection | 14 |
| 2 | Installing the Inverter | 17 |
| 2.1 | Mounting the Inverter | 19 |
| 2.2 | Enabling the RTC (Real-Time Clock) Battery..... | 23 |
| 2.3 | Cable Wiring | 25 |
| 2.4 | Post-Installation Checklist..... | 48 |
| 2.5 | Test Run..... | 50 |
| 3 | Perform Basic Operations | 52 |
| 3.1 | About the Keypad..... | 52 |
| 3.1.1 | Operation Keys | 52 |
| 3.1.2 | About the Display..... | 54 |
| 3.1.3 | Display Modes | 58 |
| 3.2 | Learning to Use the Keypad..... | 61 |
| 3.2.1 | Display Mode Selection..... | 61 |
| 3.2.2 | Operation Modes | 62 |
| 3.2.3 | Switching between Groups in Parameter Display Mode | 64 |
| 3.2.4 | Switching between Groups in User & Macro Mode | 65 |
| 3.2.5 | Navigating through the Codes (Functions) | 66 |
| 3.2.6 | Navigating Directly to Different Codes..... | 68 |
| 3.2.7 | Parameter Settings available in Monitor Mode..... | 70 |
| 3.2.8 | Setting the Monitor Display Items | 72 |
| 3.2.9 | Selecting the Status Bar Display Items | 73 |
| 3.3 | Fault Monitoring..... | 75 |
| 3.3.1 | Monitoring Faults during Inverter Operation | 75 |
| 3.3.2 | Monitoring Multiple Fault Trips | 76 |
| 3.4 | Parameter Initialization..... | 77 |
| 4 | Learning Basic Features..... | 78 |
| 4.1 | Switching between the Operation Modes (HAND / AUTO / OFF) | 81 |
| 4.2 | Setting Frequency Reference | 86 |
| 4.2.1 | Keypad as the Source (KeyPad-1 setting)..... | 87 |

| | | |
|--------|--|-----|
| 4.2.2 | Keypad as the Source (KeyPad-2 setting) | 87 |
| 4.2.3 | V1 Terminal as the Source | 87 |
| 4.2.4 | Setting a Frequency Reference with Input Voltage (Terminal I2) | 96 |
| 4.2.5 | Setting a Frequency with TI Pulse Input | 97 |
| 4.2.6 | Setting a Frequency Reference via RS-485 Communication | 99 |
| 4.3 | Frequency Hold by Analog Input | 100 |
| 4.4 | Changing the Displayed Units (Hz↔Rpm) | 101 |
| 4.5 | Setting Multi-step Frequency | 101 |
| 4.6 | Command Source Configuration | 103 |
| 4.6.1 | The Keypad as a Command Input Device | 103 |
| 4.6.2 | Terminal Block as a Command Input Device (Fwd/Rev run commands) | 104 |
| 4.6.3 | Terminal Block as a Command Input Device (Run and Rotation Direction Commands) | 105 |
| 4.6.4 | RS-485 Communication as a Command Input Device | 106 |
| 4.7 | Forward or Reverse Run Prevention | 107 |
| 4.8 | Power-on Run | 108 |
| 4.9 | Reset and Restart | 110 |
| 4.10 | Setting Acceleration and Deceleration Times | 111 |
| 4.10.1 | Acc/Dec Time Based on Maximum Frequency | 111 |
| 4.10.2 | Acc/Dec Time Based on Operation Frequency | 113 |
| 4.10.3 | Multi-step Acc/Dec Time Configuration | 113 |
| 4.10.4 | Configuring Acc/Dec Time Switch Frequency | 115 |
| 4.11 | Acc/Dec Pattern Configuration | 117 |
| 4.12 | Stopping the Acc/Dec Operation | 119 |
| 4.13 | V/F (Voltage/Frequency) Control | 121 |
| 4.13.1 | Linear V/F Pattern Operation | 121 |
| 4.13.2 | Square Reduction V/F Pattern Operation | 122 |
| 4.13.3 | User V/F Pattern Operation | 123 |
| 4.14 | Torque Boost | 125 |
| 4.14.1 | Manual Torque Boost | 125 |
| 4.14.2 | Auto Torque Boost | 126 |
| 4.14.3 | Auto Torque Boost 2 (No Motor Parameter Tuning Required) | 126 |
| 4.15 | Output Voltage Setting | 127 |
| 4.16 | Start Mode Setting | 128 |
| 4.16.1 | Acceleration Start | 128 |
| 4.16.2 | Start After DC Braking | 128 |

| | | |
|----------|--|------------|
| 4.17 | Stop Mode Setting..... | 129 |
| 4.17.1 | Deceleration Stop | 129 |
| 4.17.2 | Stop After DC Braking | 130 |
| 4.17.3 | Free Run Stop..... | 131 |
| 4.17.4 | Power Braking..... | 132 |
| 4.18 | Frequency Limit..... | 133 |
| 4.18.1 | Frequency Limit Using Maximum Frequency and Start Frequency | 133 |
| 4.18.2 | Frequency Limit Using Upper and Lower Limit Frequency Values..... | 134 |
| 4.18.3 | Frequency Jump..... | 136 |
| 4.19 | 2 nd Operation Mode Setting..... | 137 |
| 4.20 | Multi-function Input Terminal Control..... | 138 |
| 4.21 | Multi-function Input Terminal On/Off Delay Control..... | 140 |
| 5 | Learning Advanced Features..... | 141 |
| 5.1 | Operating with Auxiliary References | 143 |
| 5.2 | Jog Operation | 148 |
| 5.2.1 | Jog Operation 1-Forward Jog by Multi-function Terminal | 148 |
| 5.2.2 | Jog Operation 2-Forward/Reverse Jog by Multi-function Terminal..... | 149 |
| 5.3 | Up-down Operation..... | 150 |
| 5.4 | 3- Wire Operation | 152 |
| 5.5 | Safe Operation Mode..... | 153 |
| 5.6 | Dwell Operation | 155 |
| 5.7 | Slip Compensation Operation | 157 |
| 5.8 | PID Control | 158 |
| 5.8.1 | PID Basic Operation | 159 |
| 5.8.2 | Soft Fill Operation | 173 |
| 5.8.3 | PID Sleep Mode..... | 175 |
| 5.8.4 | PID Switching (PID Openloop) | 177 |
| 5.9 | External PID..... | 178 |
| 5.10 | Damper Operation..... | 187 |
| 5.11 | Lubrication Operation..... | 189 |
| 5.12 | Flow Compensation | 190 |
| 5.13 | Payback Counter..... | 191 |
| 5.14 | Pump Clean Operation | 192 |
| 5.15 | Start & End Ramp Operation..... | 197 |
| 5.16 | Decelerating Valve Ramping | 198 |
| 5.17 | Load Tuning..... | 199 |

| | | |
|--------|---|-----|
| 5.18 | Level Detection | 202 |
| 5.19 | Pipe Break Detection | 206 |
| 5.20 | Pre-heating Function | 208 |
| 5.21 | Auto Tuning | 210 |
| 5.22 | Time Event Scheduling | 213 |
| 5.23 | Kinetic Energy Buffering | 227 |
| 5.24 | Anti-hunting Regulation (Resonance Prevention) | 229 |
| 5.25 | Fire Mode Operation | 230 |
| 5.26 | Energy Saving Operation | 232 |
| 5.26.1 | Manual Energy Saving Operation | 232 |
| 5.26.2 | Automatic Energy Saving Operation | 233 |
| 5.27 | Speed Search Operation | 234 |
| 5.28 | Auto Restart Settings | 238 |
| 5.29 | Operational Noise Settings (Carrier Frequency Settings) | 240 |
| 5.30 | 2 nd Motor Operation | 241 |
| 5.31 | Supply Power Transition | 243 |
| 5.32 | Cooling Fan Control | 244 |
| 5.33 | Input Power Frequency and Voltage Settings | 245 |
| 5.34 | Read, Write, and Save Parameters | 246 |
| 5.35 | Parameter Initialization | 246 |
| 5.36 | Parameter View Lock | 247 |
| 5.37 | Parameter Lock | 248 |
| 5.38 | Changed Parameter Display | 249 |
| 5.39 | User Group | 250 |
| 5.40 | Easy Start On | 251 |
| 5.41 | Config (CNF) Mode | 252 |
| 5.42 | Macro Selection | 254 |
| 5.43 | Timer Settings | 255 |
| 5.44 | Multiple Motor Control (MMC) | 256 |
| 5.44.1 | Multiple Motor Control (MMC) Basic Sequence | 263 |
| 5.44.2 | Standby Motor | 268 |
| 5.44.3 | Auto Change | 269 |
| 5.44.4 | Interlock | 275 |
| 5.44.5 | Aux Motor Time Change | 279 |
| 5.44.6 | Regular Bypass | 280 |
| 5.44.7 | Aux Motor PID Compensation | 281 |
| 5.44.8 | Master Follower | 282 |
| 5.45 | Multi-function Output On/Off Control | 288 |

| | | |
|----------|--|------------|
| 5.46 | Press Regeneration Prevention | 289 |
| 5.47 | Analog Output..... | 290 |
| 5.47.1 | Voltage and Current Analog Output..... | 291 |
| 5.47.2 | Analog Pulse Output..... | 293 |
| 5.48 | Digital Output | 296 |
| 5.48.1 | Multi-function Output Terminal and Relay Settings..... | 296 |
| 5.48.2 | Fault Trip Output using Multi-function Output Terminal and Relay ... | 300 |
| 5.48.3 | Multi-function Output Terminal Delay Time Settings..... | 301 |
| 5.49 | Operation State Monitor..... | 302 |
| 5.50 | Operation Time Monitor | 304 |
| 5.51 | PowerOn Resume Using the Communication | 305 |
| 5.52 | Display current date / time / day using Multi key..... | 306 |
| 6 | Learning Protection Features | 307 |
| 6.1 | Motor Protection | 307 |
| 6.1.1 | Electronic Thermal Motor Overheating Prevention (ETH) | 307 |
| 6.1.2 | Motor Over Heat Sensor | 309 |
| 6.1.3 | Overload Early Warning and Trip..... | 311 |
| 6.1.4 | Stall Prevention and Flux Braking..... | 314 |
| 6.2 | Inverter and Sequence Protection | 318 |
| 6.2.1 | Open-phase Protection | 318 |
| 6.2.2 | External Trip Signal..... | 319 |
| 6.2.3 | Inverter Overload Protection (IOLT) | 320 |
| 6.2.4 | Speed Command Loss | 320 |
| 6.2.5 | Dynamic Braking (DB) Resistor Configuration | 324 |
| 6.2.6 | Low Battery Voltage Warning..... | 325 |
| 6.3 | Under load Fault Trip and Warning | 326 |
| 6.3.1 | Fan Fault Detection | 327 |
| 6.3.2 | Low Voltage Fault Trip..... | 327 |
| 6.3.3 | Selecting Low Voltage 2 Fault During Operation..... | 328 |
| 6.3.4 | Output Block via the Multi-function Terminal | 328 |
| 6.3.5 | Trip Status Reset | 329 |
| 6.3.6 | Operation Mode for Option Card Trip | 329 |
| 6.3.7 | No Motor Trip | 330 |
| 6.3.8 | Broken Belt..... | 332 |
| 6.4 | Parts Life Expectancy | 333 |
| 6.4.1 | Main Capacitor Life Estimation | 333 |
| 6.4.2 | Fan Life Estimation | 334 |
| 6.5 | Fault/Warning List..... | 336 |
| 7 | RS-485 Communication Features | 339 |
| 7.1 | Communication Standards | 339 |

| | | |
|----------|--|------------|
| 7.2 | Communication System Configuration | 340 |
| 7.2.1 | Communication Line Connection | 340 |
| 7.2.2 | Setting Communication Parameters | 341 |
| 7.2.3 | Setting Operation Command and Frequency..... | 342 |
| 7.2.4 | Command Loss Protective Operation | 343 |
| 7.3 | LS INV 485/Modbus-RTU Communication | 345 |
| 7.3.1 | Setting Virtual Multi-function Input | 345 |
| 7.3.2 | Saving Parameters Defined by Communication | 345 |
| 7.3.3 | Total Memory Map for Communication | 346 |
| 7.3.4 | Parameter Group for Data Transmission | 346 |
| 7.3.5 | Parameter Group for User/Macro Group | 348 |
| 7.3.6 | LS INV 485 Protocol..... | 349 |
| 7.3.7 | Modbus-RTU Protocol..... | 354 |
| 7.3.8 | Compatible Common Area Parameter | 358 |
| 7.3.9 | H100 Expansion Common Area Parameter | 362 |
| 7.4 | BACnet Communication | 377 |
| 7.4.1 | What is BACnet Communication? | 377 |
| 7.4.2 | BACnet Communication Standards | 377 |
| 7.4.3 | BACnet Quick Communication Start..... | 377 |
| 7.4.4 | Protocol Implementation..... | 379 |
| 7.4.5 | Object Map | 380 |
| 7.5 | Metasys-N2 Communication | 388 |
| 7.5.1 | Metasys-N2 Quick Communication Start..... | 388 |
| 7.5.2 | Metasys-N2 Communication Standard | 388 |
| 7.5.3 | Metasys-N2 Protocol I/O Point Map | 389 |
| 8 | Table of Functions..... | 392 |
| 8.1 | Drive Group (DRV)..... | 393 |
| 8.2 | Basic Function Group (BAS) | 398 |
| 8.3 | Expanded Function Group (ADV) | 404 |
| 8.4 | Control Function Group (CON) | 411 |
| 8.5 | Input Terminal Group (IN) | 414 |
| 8.6 | Output Terminal Block Function Group (OUT) | 423 |
| 8.7 | Communication Function Group (COM)..... | 429 |
| 8.8 | Advanced Function Group(PID Functions) | 436 |
| 8.9 | EPID Function Group (EPI) | 447 |
| 8.10 | Application 1 Function Group (AP1) | 454 |
| 8.11 | Application 2 Function Group (AP2) | 461 |
| 8.12 | Application 3 Function Group (AP3) | 467 |

| | | |
|-----------|--|------------|
| 8.13 | Protection Function Group (PRT)..... | 474 |
| 8.14 | 2nd Motor Function Group (M2)..... | 484 |
| 8.15 | Trip (TRIP Last-x) and Config (CNF) Mode..... | 488 |
| | 8.15.1 Trip Mode (TRP Last-x)..... | 488 |
| | 8.15.2 Config Mode (CNF)..... | 488 |
| 8.16 | Macro Groups..... | 494 |
| | 8.16.1 Compressor (MC1) Group..... | 494 |
| | 8.16.2 Supply Fan (MC2) Group..... | 496 |
| | 8.16.3 Exhaust Fan (MC3) Group..... | 498 |
| | 8.16.4 Cooling Tower (MC4) Group..... | 507 |
| | 8.16.5 Circulation Pump (MC5) Group..... | 509 |
| | 8.16.6 Vacuum Pump (MC6) Group..... | 513 |
| | 8.16.7 Constant Torque (MC7) Group..... | 520 |
| 9 | Troubleshooting..... | 523 |
| 9.1 | Trip and Warning..... | 523 |
| | 9.1.1 Fault Trips..... | 523 |
| | 9.1.2 Warning Message..... | 526 |
| 9.2 | Troubleshooting Fault Trips..... | 528 |
| 9.3 | Troubleshooting Other Faults..... | 531 |
| 10 | Maintenance..... | 537 |
| 10.1 | Regular Inspection Lists..... | 537 |
| | 10.1.1 Daily Inspection..... | 537 |
| | 10.1.2 Annual Inspection..... | 538 |
| | 10.1.3 Bi-annual Inspection..... | 540 |
| 10.2 | Real Time Clock (RTC) Battery Replacement..... | 541 |
| 10.3 | Storage and Disposal..... | 545 |
| | 10.3.1 Storage..... | 545 |
| | 10.3.2 Disposal..... | 545 |
| 11 | Technical Specification..... | 546 |
| 11.1 | Input and Output Specifications..... | 546 |
| 11.2 | Product Specification Details..... | 551 |
| 11.3 | External Dimensions..... | 556 |
| 11.4 | Peripheral Devices..... | 561 |
| 11.5 | Fuse and Reactors Specifications..... | 563 |
| 11.6 | Terminal Screw Specifications..... | 565 |
| 11.7 | Dynamic breaking unit (DBU) and Resistors..... | 567 |
| | 11.7.1 Dynamic breaking unit (DBU)..... | 567 |
| | 11.7.2 Terminal arrangement..... | 569 |
| | 11.7.3 Dynamic Breaking (DB)Unit & DB resistor basic wiring..... | 571 |

| | |
|--|------------|
| 11.7.4 Dimensions | 572 |
| 11.7.5 Display Functions | 576 |
| 11.7.6 DB Resistors | 576 |
| 11.8 Inverter Continuous Rated Current Derating..... | 578 |
| 12 Applying Drives to Single-phase Input Application..... | 581 |
| 12.1 Introduction | 581 |
| 12.2 Power(HP), Input Current and Output Current..... | 582 |
| 12.3 Input Frequency and Voltage Tolerance | 583 |
| 12.4 Wiring | 584 |
| 12.5 Precautions for 1-phase input to 3-phase drive..... | 584 |
| Product Warranty | 585 |
| UL mark..... | 587 |
| EAC mark..... | 587 |
| Index | 591 |

1 Preparing the Installation

This chapter provides details on product identification, part names, correct installation and cable specifications. To install the inverter correctly and safely, carefully read and follow the instructions.

1.1 Product Identification

The H100 Inverter is manufactured in a range of product groups based on drive capacity and power source specifications. Product name and specifications are detailed on the rating plate. Check the rating plate before installing the product and make sure that the product meets your requirements. For more detailed product specifications, refer to [11.1 Input and Output Specifications](#) on page [546](#).

Note

Check the product name, open the packaging, and then confirm that the product is free from defects. Contact your supplier if you have any issues or questions about your product.



LSLV0055H100-4COFN

INPUT 380-480V 3 Phase 50/60Hz
 HD: 11.0A, ND: 14.7A

OUTPUT 0-Input V 3 Phase 0.01-400Hz
 HD: 12A, ND: 16A
 9.1kVA

Ser. No 55025310146
 Inspected by D. K. YU
 KCC-REM-LSR-XXXXXXX

Model name

Power source specifications

Output specifications

LSLV 0055 H100 - 4CEFN

| | |
|-----------------------|--------------|
| Motor capacity | |
| 0008 - 0.75kW | 0550 - 55kW |
| 0015 - 1.5kW | 0750 - 75kW |
| 0022 - 2.2kW | 0900 - 90kW |
| 0037 - 3.7kW | 1100 - 110kW |
| 0055 - 5.5kW | 1320 - 132kW |
| 0075 - 7.5kW | 1600 - 160kW |
| 0110 - 11kW | 1850 - 185kW |
| 0150 - 15kW | 2200 - 220kW |
| 0185 - 18.5kW | 2500 - 250kW |
| 0220 - 22kW | 3150 - 315kW |
| 0330 - 30kW | 3550 - 355kW |
| 0370 - 37kW | 4000 - 400kW |
| 0450 - 45kW | 5000 - 500kW |

Series name _____

Input voltage

2 - 3-phase 200V _____

4 - 3-phase 400V _____

Keypad type

C - LCD Keypad _____

UL type

O - UL Open _____

E - UL Type1 _____

EMC filter

F : Built-in EMC _____

N : No Built-in EMC _____

Reactor

D - Built-in DCL _____

N - No Built-in Reactor _____

Note

The H100 75/90 kW, 400 V inverters satisfy the EMC standard EN61800-3 without installation of optional EMC filters.

1.2 Part Names

The illustration below displays part names. Details may vary between product groups.

0.75–30 kW (3-Phase)

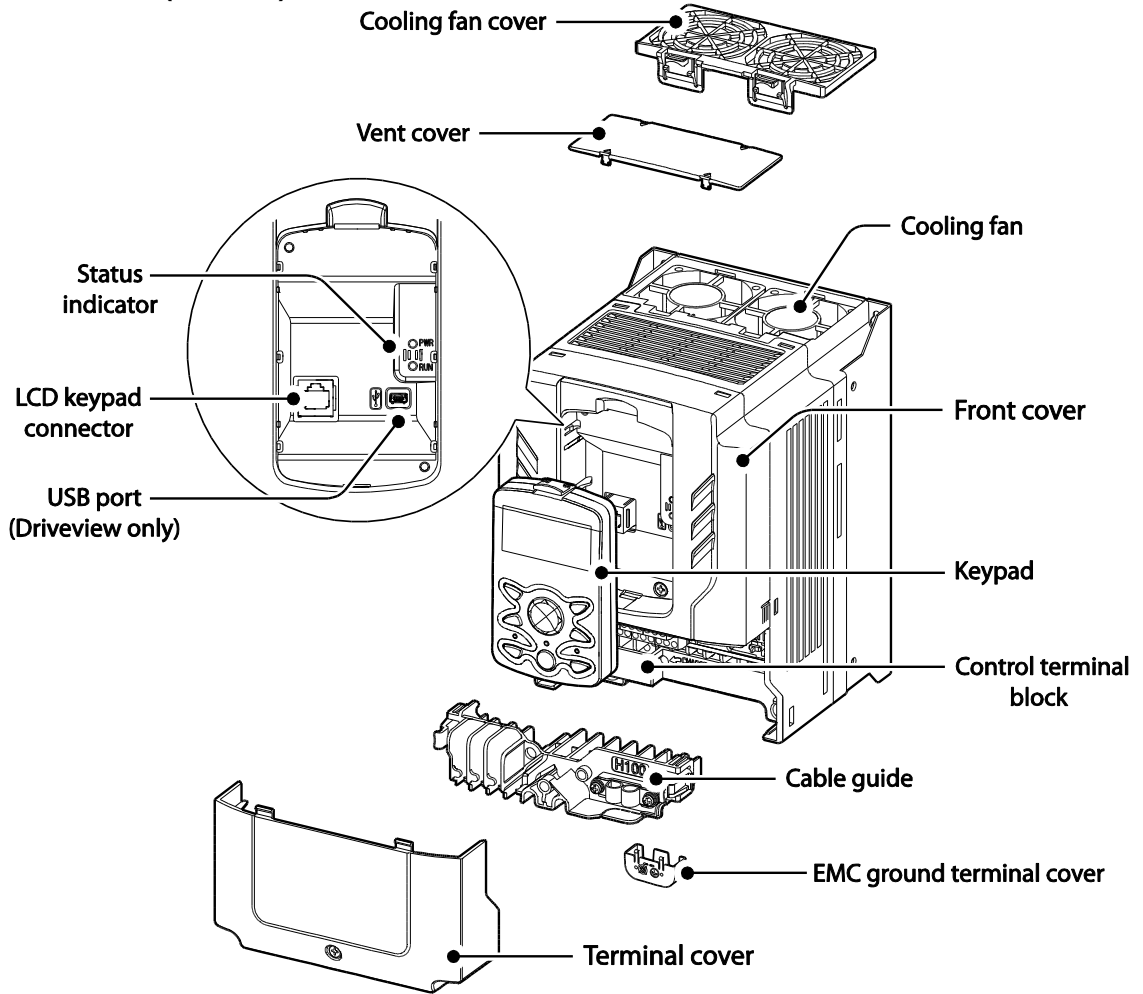

37–90 kW (3-Phase)

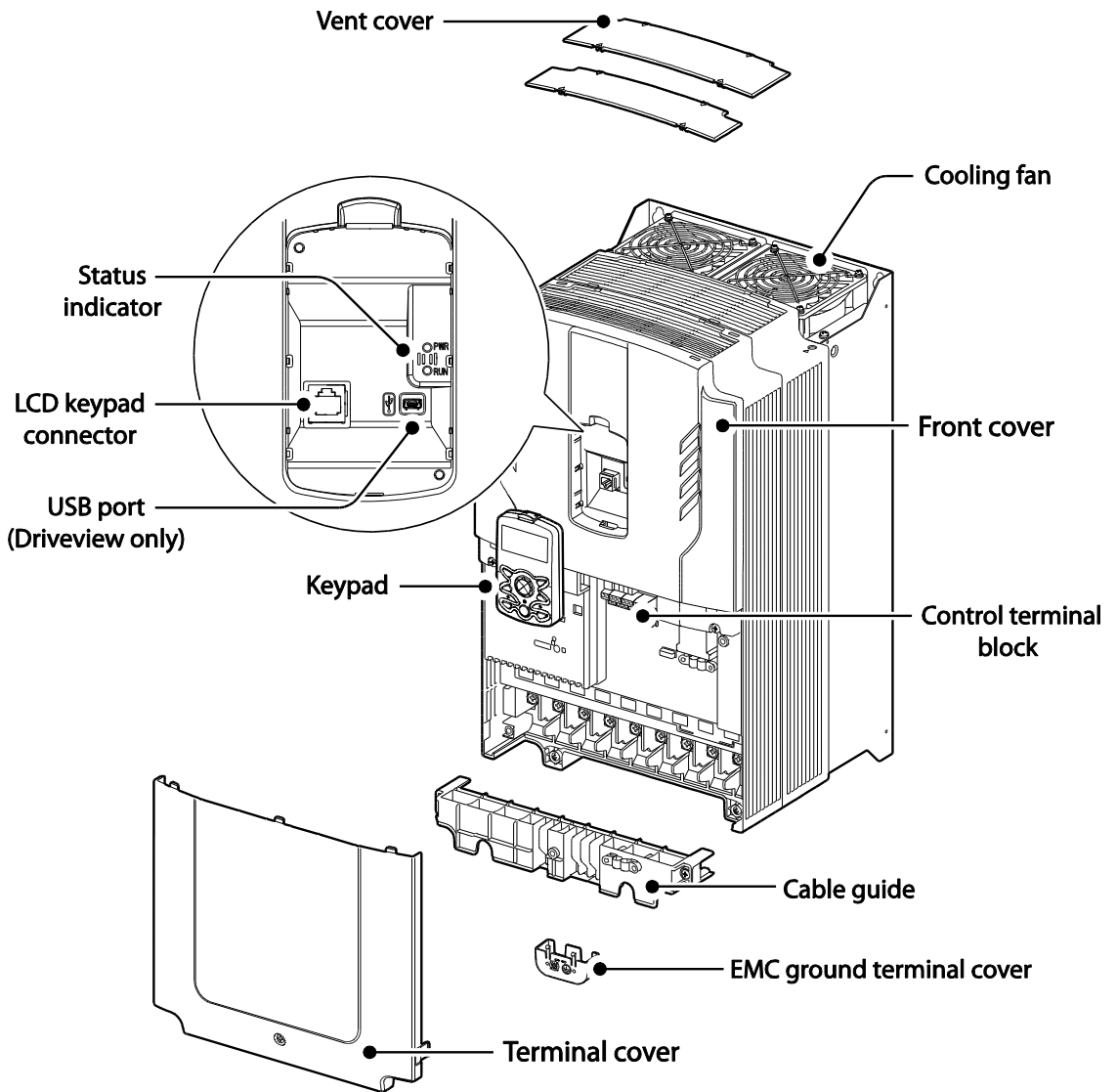

110–132 kW (3-Phase)

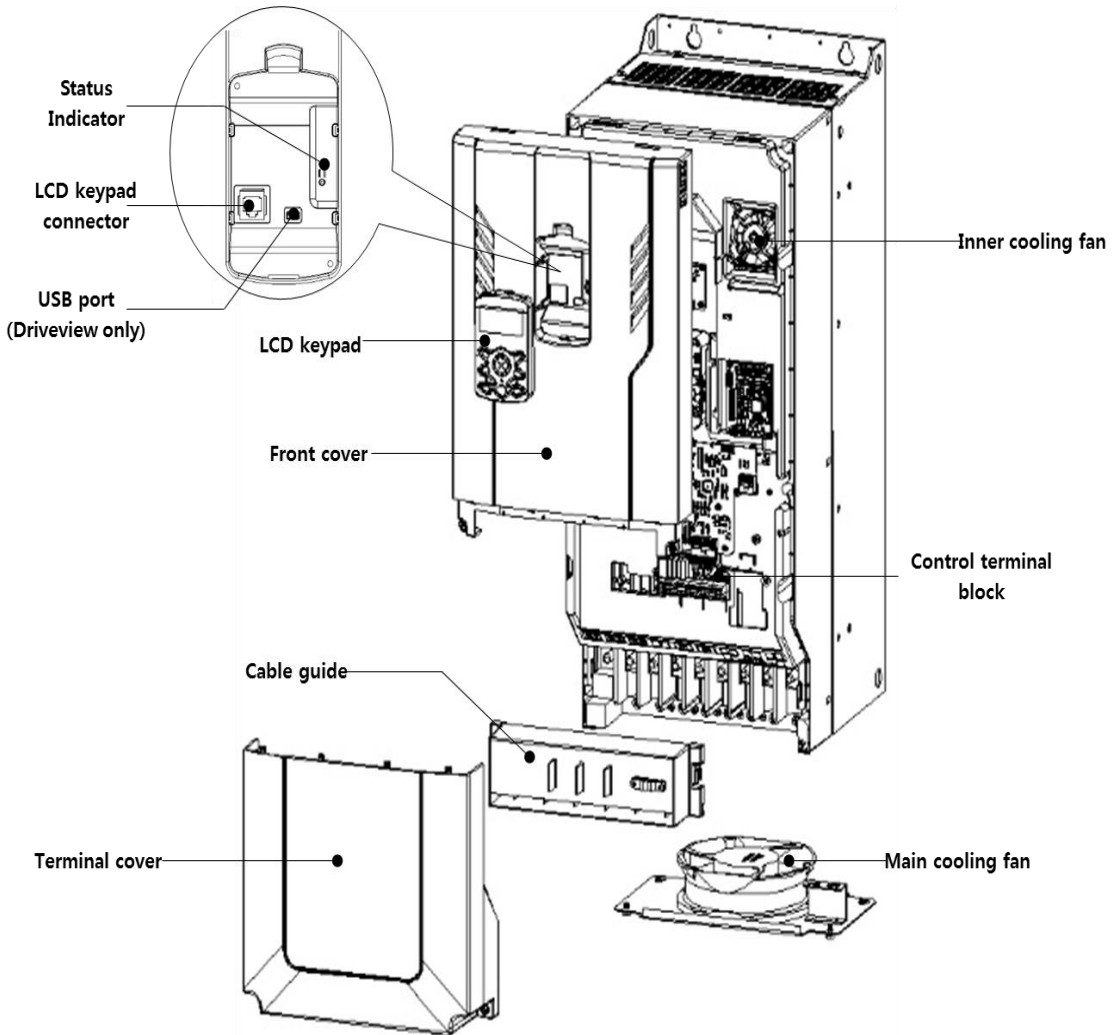

160–185 kW (3-Phase)

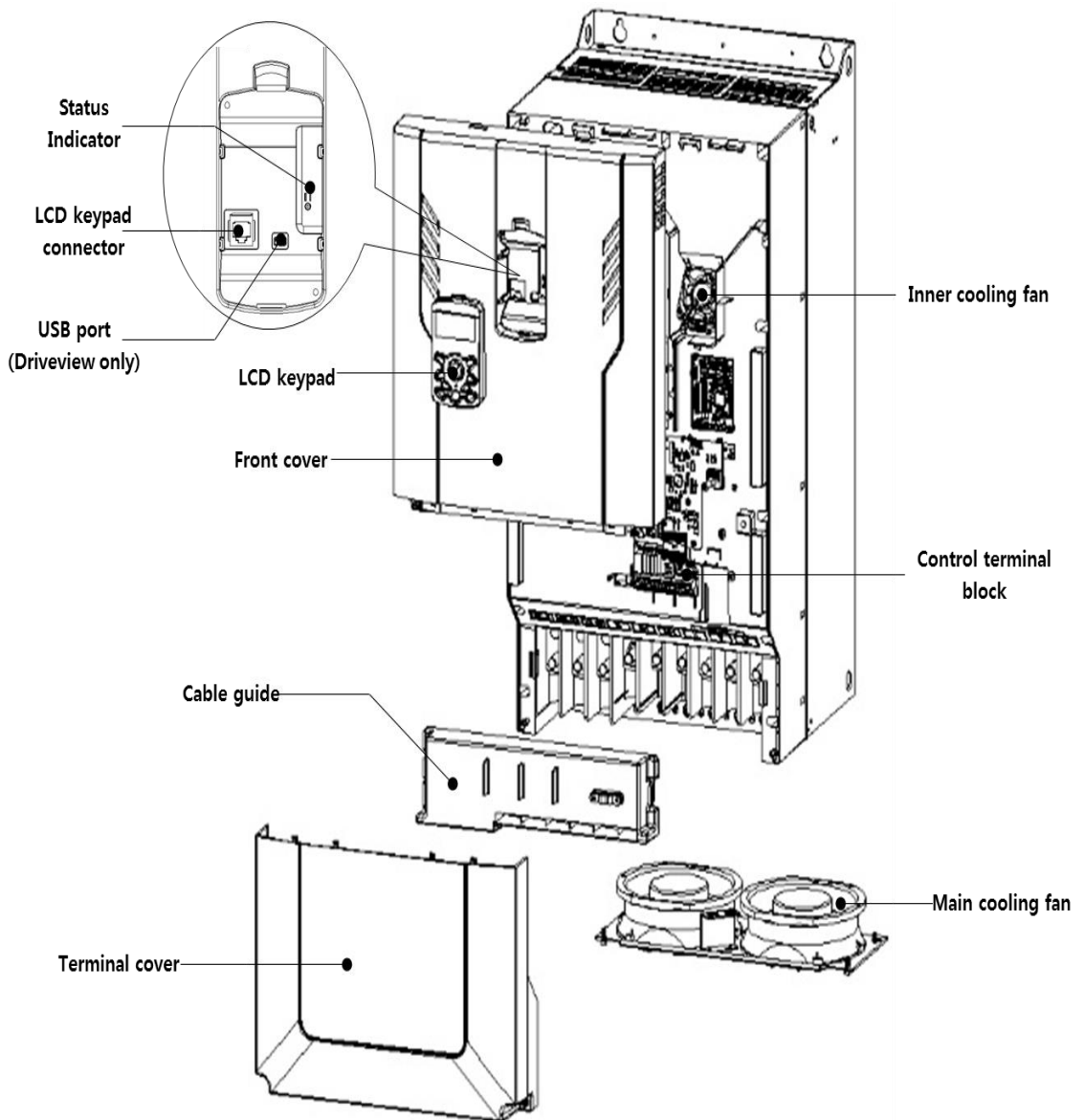

220–250 kW (3-Phase)

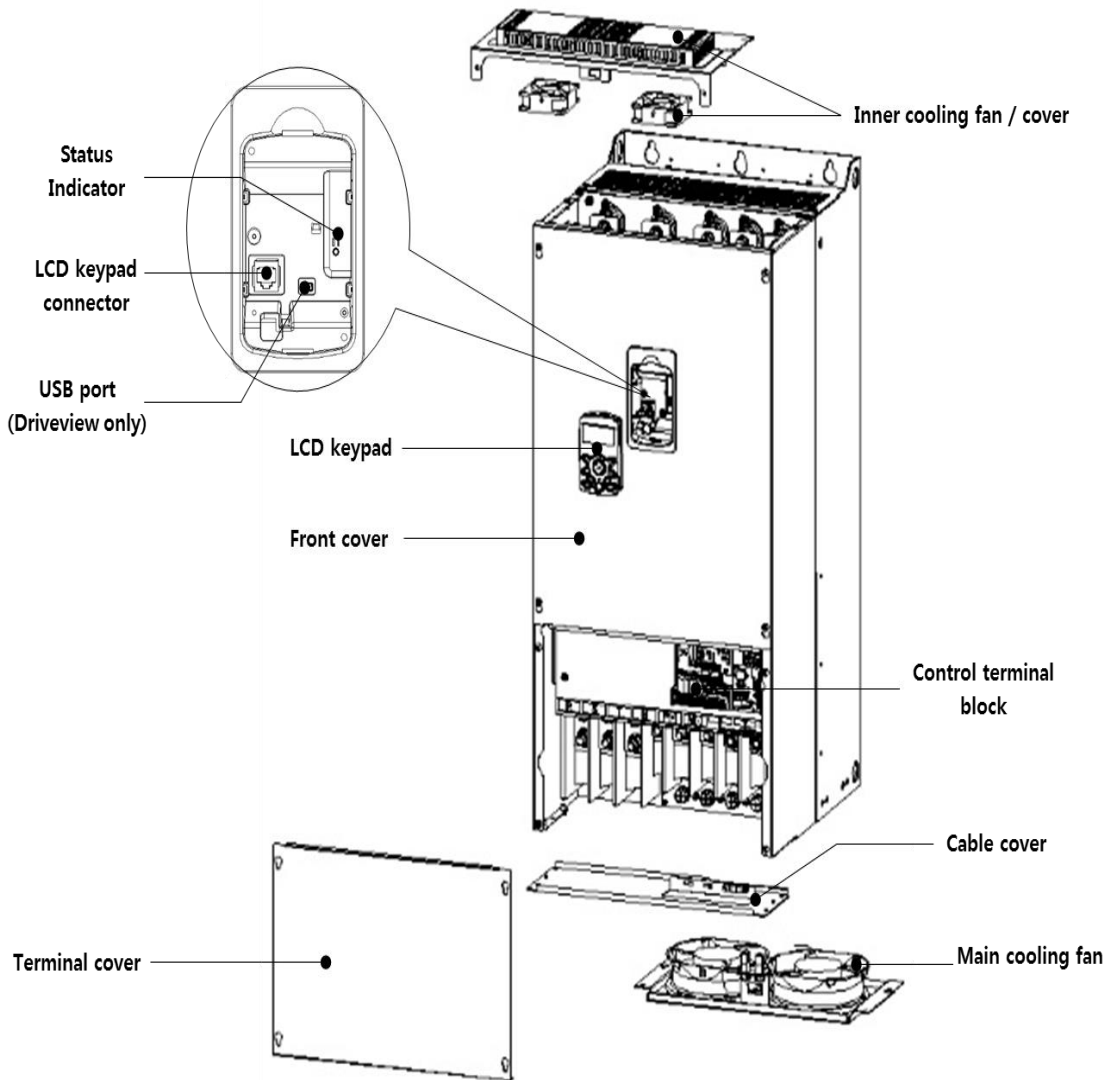

315–400 kW (3-Phase)

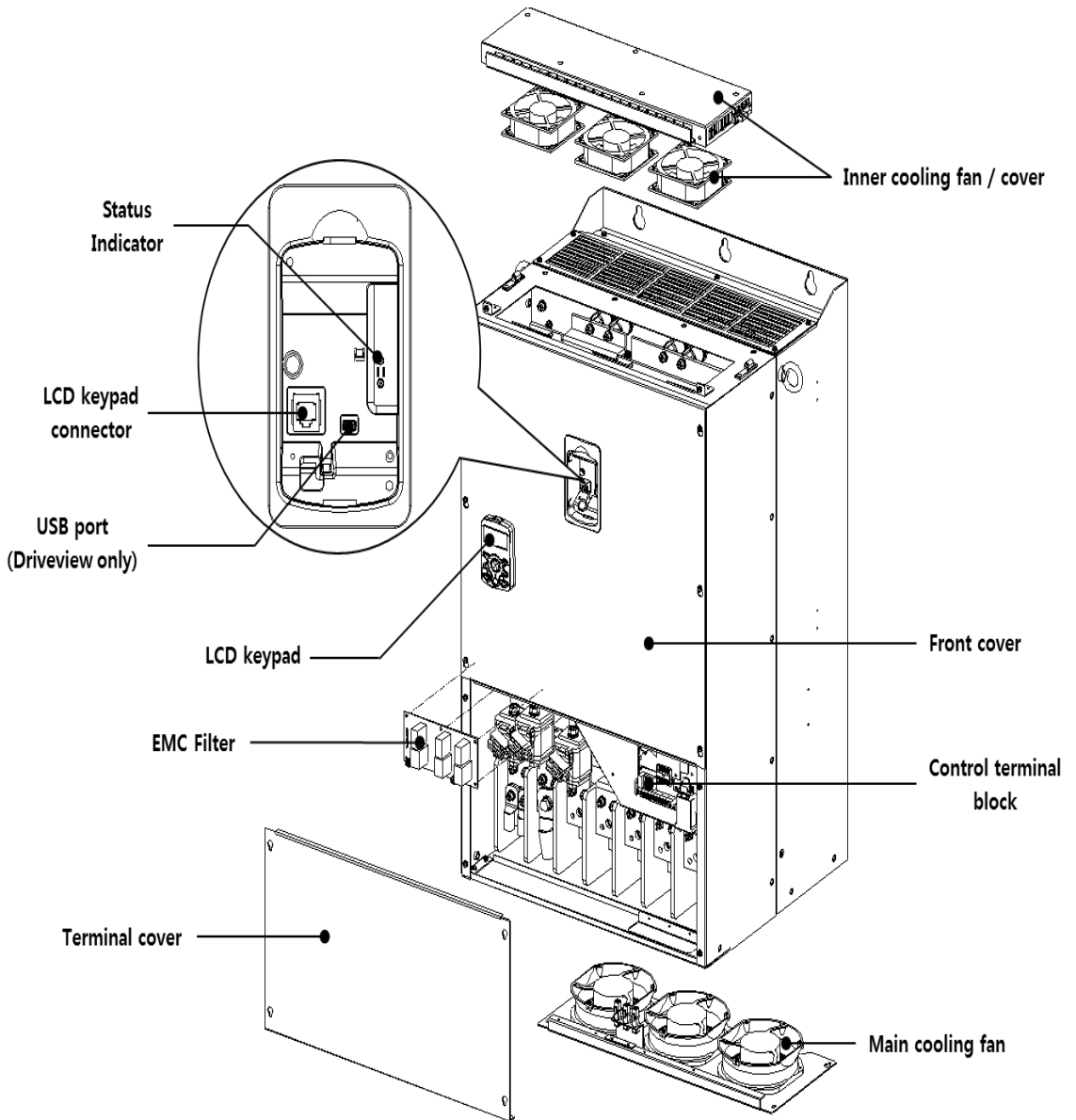

500 kW (3-Phase)

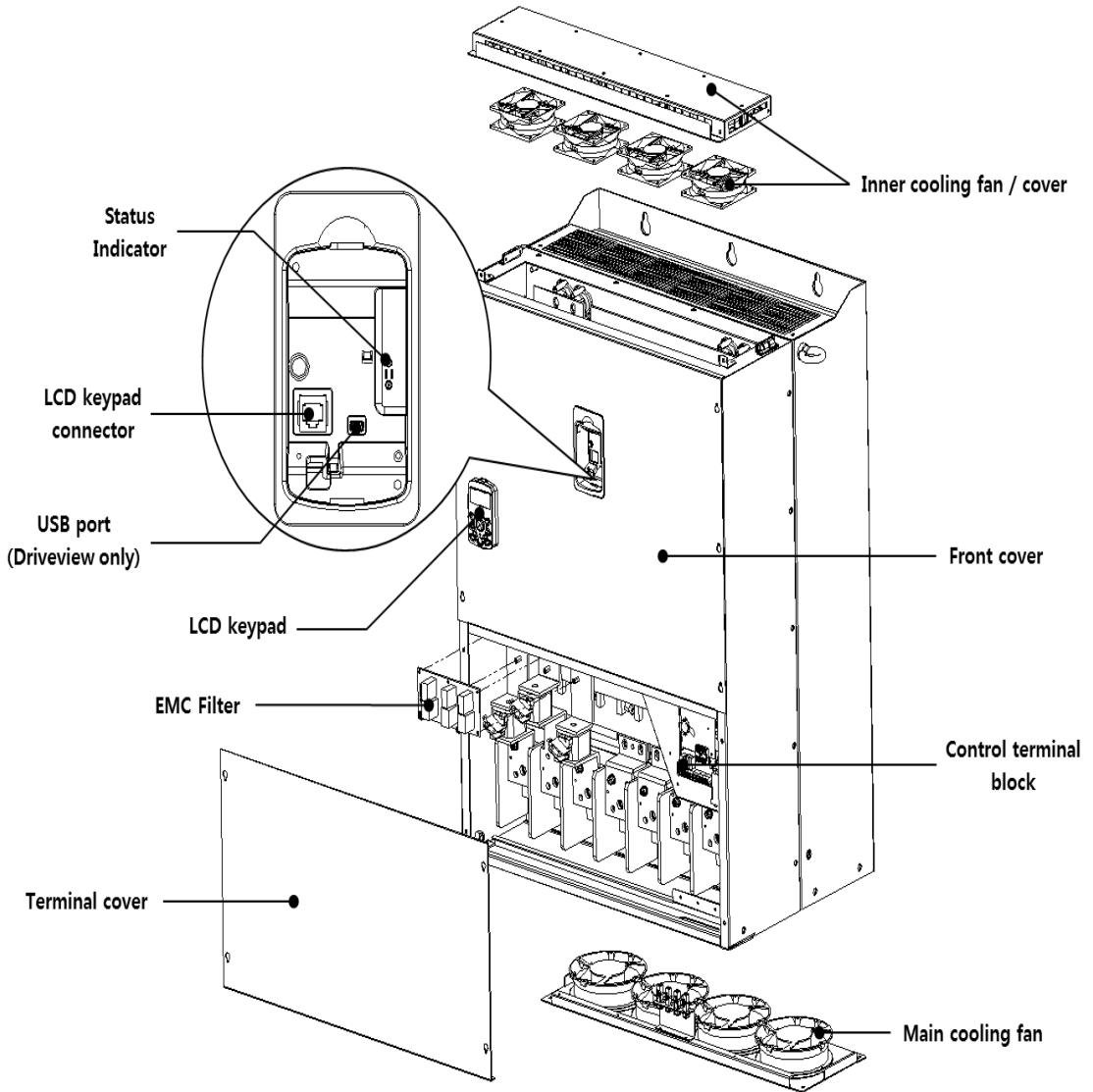

1.3 Installation Considerations

Inverters are composed of various precision, electronic devices, and therefore the installation environment can significantly impact the lifespan and reliability of the product. The table below details the ideal operation and installation conditions for the inverter.

| Items | Description |
|-----------------------|---|
| Ambient Temperature* | -10 °C–50 °C (40 °C and above, 2.5% / °C Current Derating search. 50 °C 75% of the rated current of the drive if possible) |
| Ambient Humidity | 95% relative humidity (no condensation) |
| Storage Temperature | - 4–149 °F (-20–65 °C) |
| Environmental Factors | An environment free from corrosive or flammable gases, oil residue or dust |
| Altitude | Maximum 3,280 ft (1,000m) above sea level for standard operation. After that the driver rated voltage and the rated output current derating by 1% for every extra 328 ft (100m) up to 13,123 ft (4,000m). |
| Vibration | less than 1.0 G (9.8m/sec ²) |
| Air Pressure | 70 –106 kPa |

* The ambient temperature is the temperature measured at a point 2" (5 cm) from the surface of the inverter.

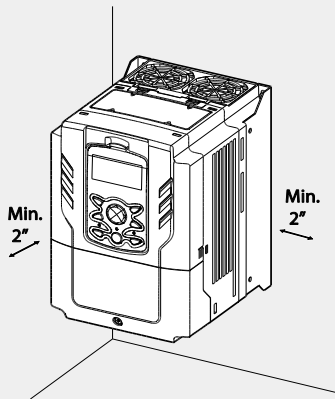

⚠ Caution

Do not allow the ambient temperature to exceed the allowable range while operating the inverter.

1.4 Selecting and Preparing a Site for Installation

When selecting an installation location consider the following points:

- The inverter must be installed on a wall that can support the inverter's weight.
- The location must be free from vibration. Vibration can adversely affect the operation of the inverter.
- The inverter can become very hot during operation. Install the inverter on a surface that is fire-resistant or flame-retardant and with sufficient clearance around the inverter to allow air to circulate. The illustrations below detail the required installation clearances.

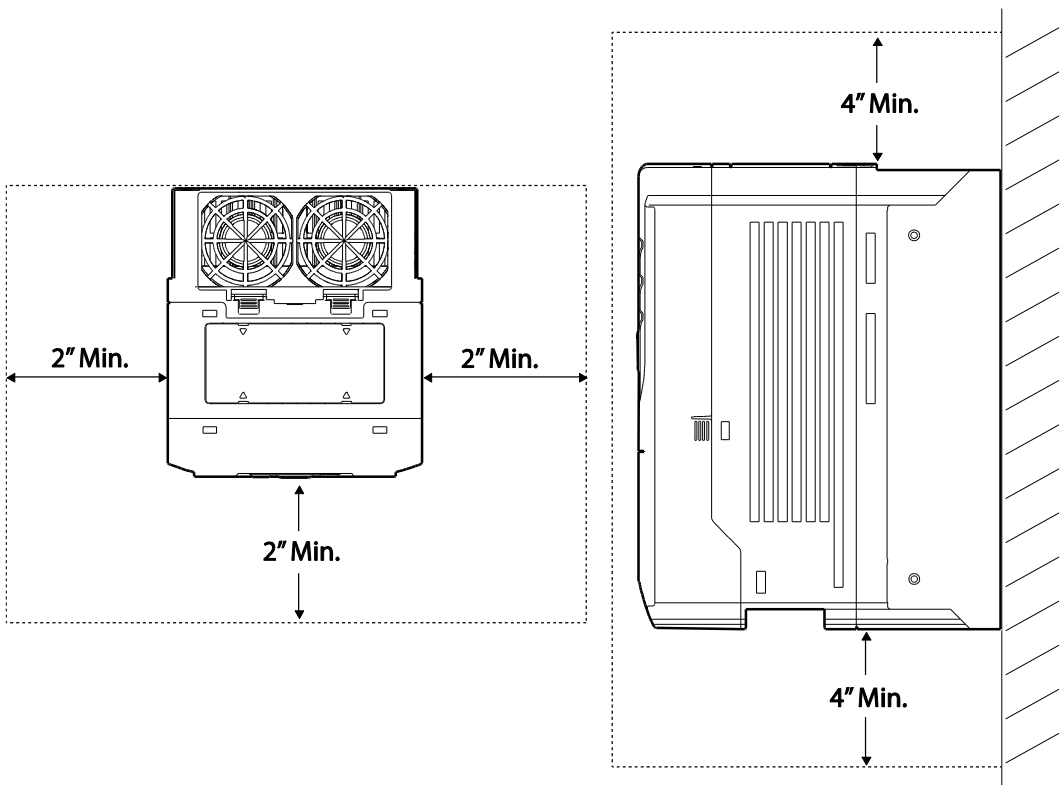

Preparing the Installation

- Ensure sufficient air circulation is provided around the inverter when it is installed. If the inverter is to be installed inside a panel, enclosure, or cabinet rack, carefully consider the position of the inverter's cooling fan and the ventilation louver. The cooling fan must be positioned to efficiently transfer the heat generated by the operation of the inverter.

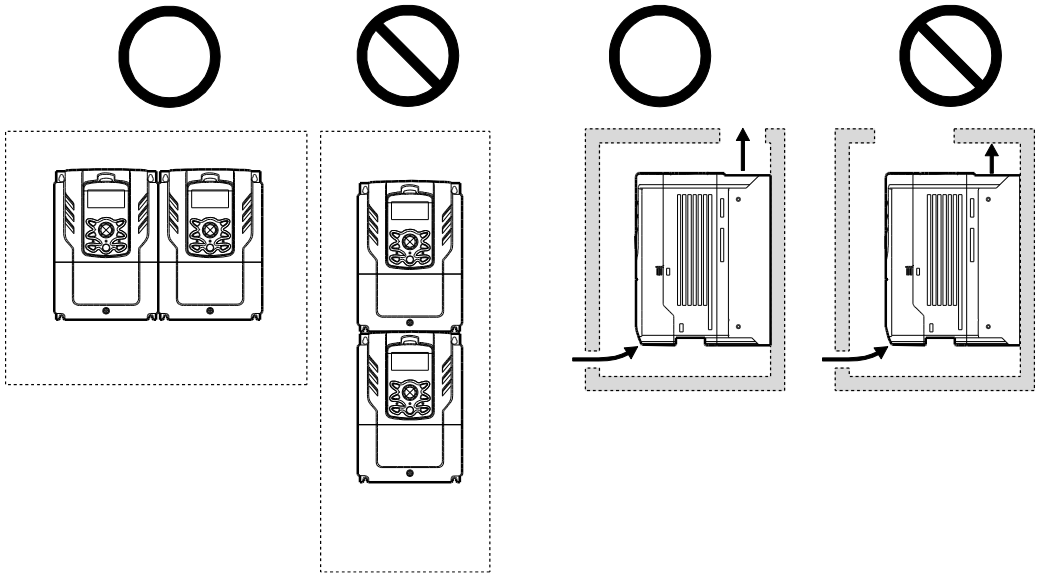

- If you are installing multiple inverters in one location, arrange them side-by-side and remove the vent covers. Use a flat head screwdriver to remove the vent covers. Only the H100 inverters rated for up to 30 kW may be installed side-by-side.

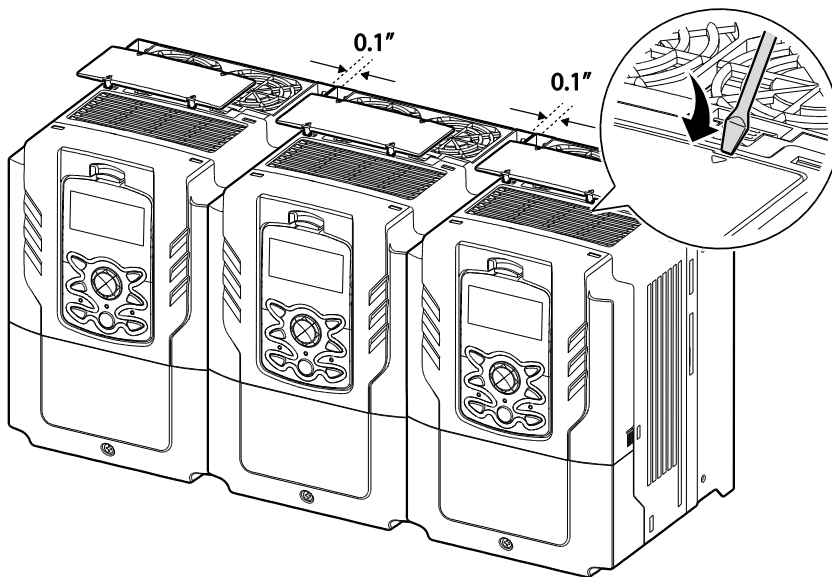

Note

- The vent covers must be removed for side-by-side installations.
- Side-by-side installation cannot be used for the H100 inverters rated for 37 kW and above.
- For the H100 inverters rated for 37 kW and above, if the installation site satisfies the UL Open Type requirements and there is no danger of foreign objects getting inside the inverter and causing trouble, the vent cover may be removed to improve cooling efficiency.
- If you are installing multiple inverters of different ratings, provide sufficient clearance to meet the clearance specifications of the larger inverter. The H100 inverters rated for up to 30 kW may be installed side-by-side.

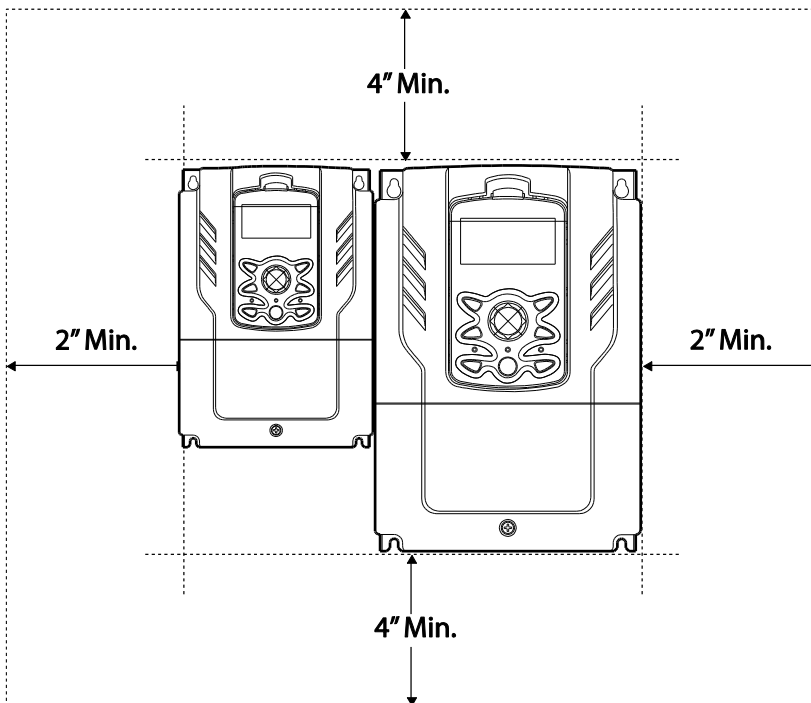

1.5 Cable Selection

When you install power and signal cables in the terminal blocks, only use cables that meet the required specification for the safe and reliable operation of the product. Refer to the following information to assist you with cable selection.

⚠ Caution

- Wherever possible use cables with the largest cross-sectional area for mains power wiring, to ensure that voltage drop does not exceed 2%.
- Use copper cables rated for 600 V, 75 °C for power terminal wiring.
- Use copper cables rated for 300 V, 75 °C for control terminal wiring.
- The inverters in the range between 15 and 90 kW must be grounded conveniently with fixed connections.
- The inverters in the range between 5,5kW and 11kW must be grounded with and industrial connector according to IEC 60309.
- The minimum size of the protective earthing conductor shall comply with the local safety regulations for high protective earthing conductor current equipment.
- Only one conductor per terminal should be simultaneously connected

Ground Cable and Power Cable Specifications

| Load (kW) | Ground Wire | | Input/Output Power Wire | | | | |
|------------------|-----------------|-----|-------------------------|-------|-------|-------|----|
| | mm ² | AWG | mm ² | | AWG | | |
| | | | R/S/T | U/V/W | R/S/T | U/V/W | |
| 3-Phase 200 V | 0.75 | 3.5 | 12 | 1.5 | 1.5 | 16 | 16 |
| | 1.5 | | | | | | |
| | 2.2 | | | | | | |
| | 3.7 | 10 | 10 | 2.5 | 2.5 | 14 | 14 |
| | 5.5 | | | 4 | 4 | 12 | 12 |
| | 7.5 | | | 6 | 6 | 10 | 10 |
| | 11 | 14 | 6 | 10 | 10 | 8 | 8 |
| | 15 | | | 16 | 16 | 6 | 6 |
| | 18.5 | | | 25 | 22 | 4 | 4 |
| 3-Phase 400 V | 0.75 | 2 | 14 | 1.5 | 1.5 | 16 | 16 |
| | 1.5 | | | | | | |
| | 2.2 | | | | | | |

| Load (kW) | Ground Wire | | Input/Output Power Wire | | | |
|-----------|-----------------|-----------------|-------------------------|-----------------|-------------------|-------------------|
| | mm ² | AWG | mm ² | | AWG | |
| | | | R/S/T | U/V/W | R/S/T | U/V/W |
| 3.7 | | | | | | |
| 5.5 | 4 | 12 | 2.5 | 2.5 | 14 | 14 |
| 7.5 | | | 4 | 2.5 | 12 | 14 |
| 11 | | | 4 | 4 | 12 | 12 |
| 15 | 16 | 9 | 6 | 6 | 10 | 10 |
| 18.5 | | | 16 | 10 | 6 | 8 |
| 22 | 14 | 6 | 16 | 10 | 6 | 8 |
| 30 | | | 25 | 16 | 4 | 6 |
| 37 | | | 25 | 4 | 25 | 25 |
| 45 | 25 | 25 | | | 4 | 4 |
| 55 | 50 | 50 | | | 1/0 | 1/0 |
| 75 | 38 | 2 | 70 | 70 | 1/0 | 1/0 |
| 90 | | | 70 | 70 | 1/0 | 1/0 |
| 110 | 50X2 | 1X2 | 70X2 | 70X2 | 1/0 x2 300 | 1/0 x2 300 |
| 132 | | | 95X2 | 95X2 | 2/0 x2 400 | 2/0 x2 400 |
| 160 | 50X2 70X2 | 1/0 x2 | 95X2 | 95X2 | 4/0 x2 | 4/0 x2 |
| 185 | 70x2 95x2 | 3/0 x2 | 120X2 | 120X2 | 250 x2 | 250 x2 |
| 220 | 95x2 | 250x2 | 150X2 | 150X2 | 300 x2 | 300 x2 |
| 250 | | 300 x2 | 185X2 | 185X2 | 350 x2 | 350 x2 |
| 315 | 60X4 150X2 | 2/0 x4, | 120X4, 400X2 | 120X4, 400X2 | 250 x4 800 x2 | 250 x4 800 x2 |
| 355 | 70X4 150X2 | 3/0 x4 | | | | |
| 400 | 95X4 200X2 | 4/0 x4 | | | | |
| 500 | 120X4 350X2 | 4/0 x4 750X2 | 185X4, 630X2 | 185X4, 630X2 | 350 x4 1500 x2 | 350 x4 1500 x2 |

* Lugs of the field wiring must be UL approved.

Signal (Control) Cable Specifications

| Terminals | Wire thickness ¹⁾ | |
|----------------------------------|------------------------------|-------|
| | mm ² | AWG |
| P1-P7/CM/VR/V1/I2/24/T1 | 0.33-1.25 | 16-22 |
| AO1/AO2/CM/Q1/EG | 0.33-2.0 | 14-22 |
| A1/B1/C1/A2/C2/A3/C3/A4/C4/A5/C5 | 0.33-2.0 | 14-22 |
| S+,S-,SG | 0.75 | 18 |

1) Use STP (shielded twisted-pair) cables for signal wiring.

2 Installing the Inverter

This chapter describes the physical and electrical installation of the H100 series inverters, including mounting and wiring of the product. Refer to the flowchart and basic configuration diagram provided below to understand the procedures and installation instructions to be followed to install the product correctly.

Installation Flowchart

The following flowchart lists the sequence to be followed during installation. The steps cover equipment installation and testing of the product. More information on each step is referenced in the steps.

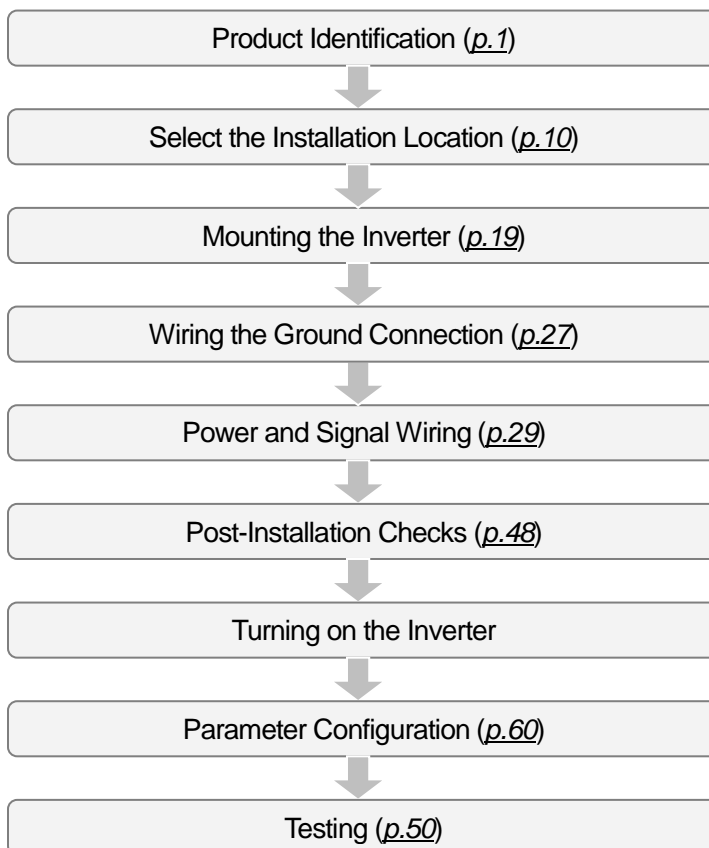

Basic configuration diagram

The reference diagram below shows a typical system configuration showing the inverter and peripheral devices.

Prior to installing the inverter, ensure that the product is suitable for the application (power rating, capacity, etc). Ensure that all of the required peripherals and optional devices (resistor brakes, contactors, noise filters, etc.) are available. For more details on peripheral devices, refer to [11.4 Peripheral Devices](#) on page 561.

200[V] : 0.75~18.5kW, 400[V] : 0.75~30kW

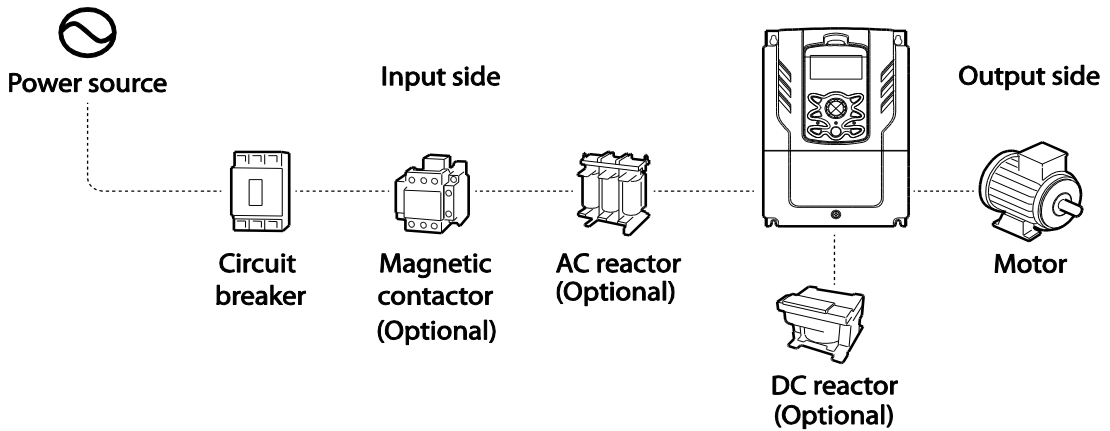

400[V] : 37~500kW

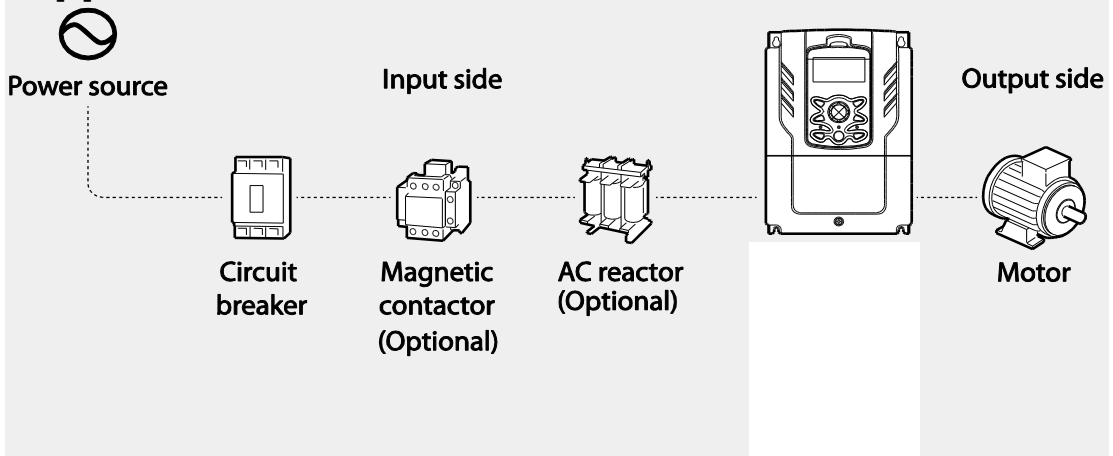

⚠ Caution

- Figures in this manual are shown with covers or circuit breakers removed to show a more detailed view of the installation arrangements. Install covers and circuit breakers before operating the inverter. Operate the product according to the instructions in this manual.
- Do not start or stop the inverter using a magnetic contactor installed on the input power supply.
- If the inverter is damaged and loses control, the machine may cause a dangerous situation. Install an additional safety device such as an emergency brake to prevent these situations.
- High levels of current draw during power-on can affect the system. Ensure that correctly rated circuit breakers are installed to operate safely during power-on situations.
- Reactors can be installed to improve the power factor. Note that reactors may be installed within 32.8 ft (10 m) from the power source if the input power exceeds 600 kVA. Refer to 11.5 Fuse and Reactors Specifications on page 563 and carefully select a reactor that meets the requirements.

2.1 Mounting the Inverter

Mount the inverter on a wall or inside a panel following the procedures provided below. Before installation, ensure that there is sufficient space to meet the clearance specifications, and that there are no obstacles impeding the cooling fan's air flow.

Select a wall or panel suitable to support the installation. Refer to 11.3 External Dimensions on page 556 and check the inverter's mounting bracket dimensions.

- 1 Use a level to draw a horizontal line on the mounting surface, and then carefully mark the fixing points.
- 2 Drill the two upper mounting bolt holes, and then install the mounting bolts. Do not fully tighten the bolts at this time. Fully tighten the mounting bolts after the inverter has been mounted.
- 3 Mount the inverter on the wall or inside a panel using the two upper bolts, and then fully tighten the upper mounting bolts.

200[V] : 0.75~18.5kW, 400[V] : 0.75~185kW

Installing the Inverter

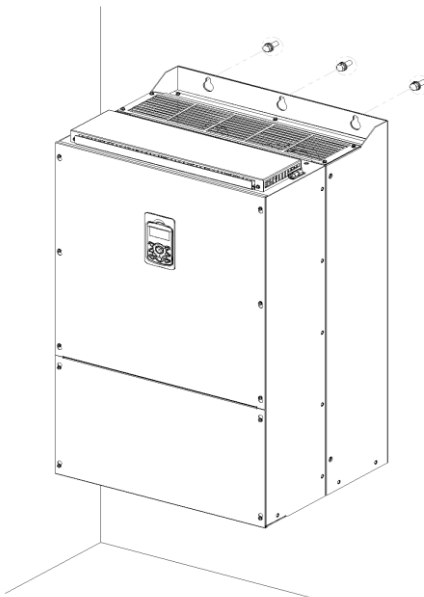
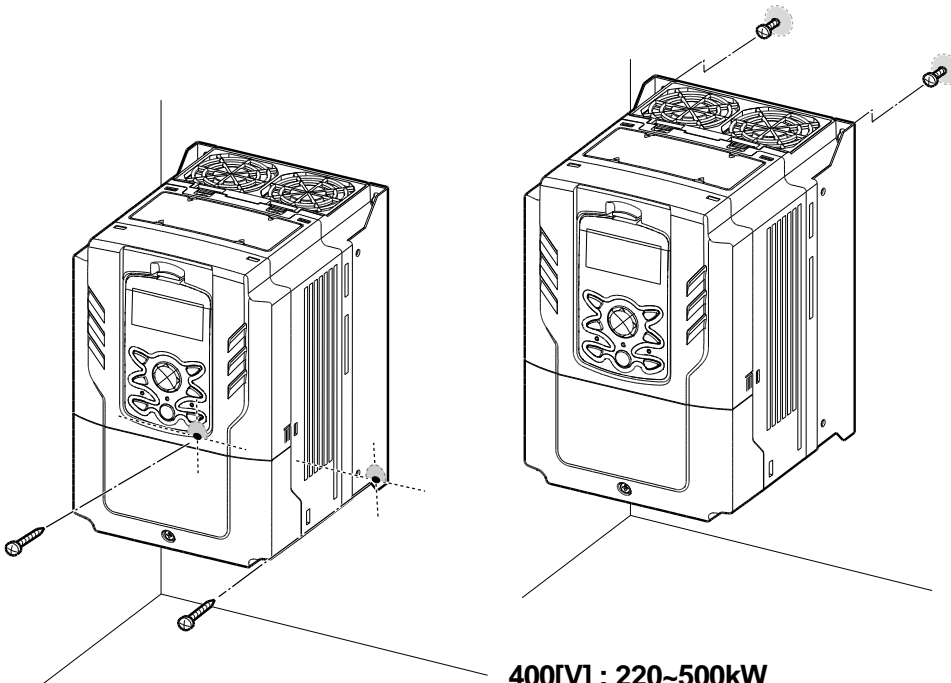

- 4 Install the two lower mounting bolts. Ensure that the inverter is placed flat on the mounting surface, and that the installation surface can securely support the weight of the inverter.

400[V] : 220~500kW



⚠ Caution

- Do not transport the inverter by lifting with the inverter's covers or plastic surfaces. The inverter may tip over if covers break, causing injuries or damage to the product. Always support the inverter using the metal frames when moving it.
- Hi-capacity inverters are very heavy and bulky. Use an appropriate transport method that is suitable for the weight.
- Do not install the inverter on the floor or mount it sideways against a wall. The inverter must be installed vertically, on a wall or inside a panel, with its rear flat on the mounting surface.

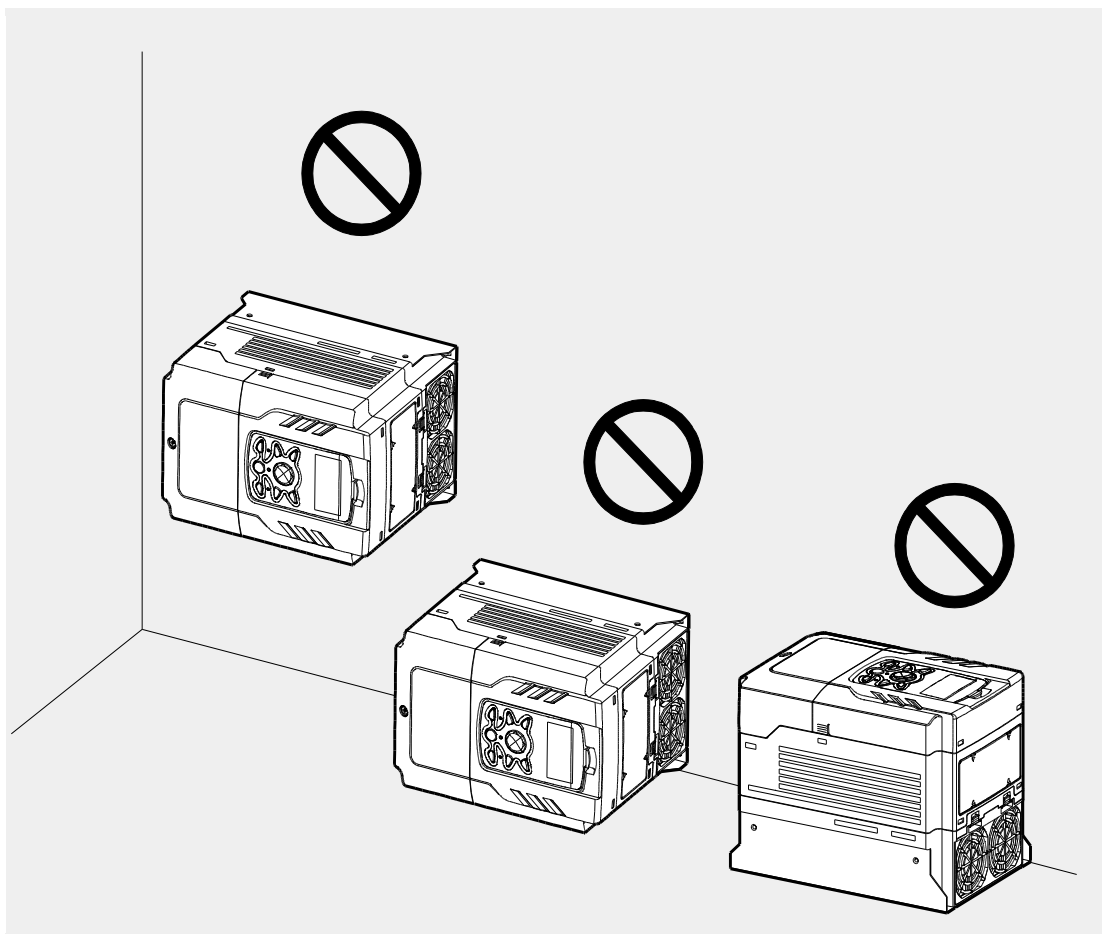

2.2 Enabling the RTC (Real-Time Clock) Battery

The H100 series inverter comes from the factory with a CR2032 lithium-manganese battery pre-installed on the I/O PCB. The battery powers the inverter's built-in RTC. The battery is installed with a protective insulation strip to prevent battery discharge; remove this protective film before installing and using the inverter.

⚠ Caution

ESD (Electrostatic discharge) from the human body may damage sensitive electronic components on the PCB. Therefore, be extremely careful not to touch the PCB or the components on the PCB with bare hands while you work on the I/O PCB.

To prevent damage to the PCB from ESD, touch a metal object with your hands to discharge any electricity before working on the PCB, or wear an anti-static wrist strap and ground it on a metal object.

Follow the instructions below to remove the protective insulation strip and enable the RTC feature on the H100 series inverters.

- 1 Turn off the inverter and make sure that DC link voltage has dropped to a safe level.
- 2 Loosen the screw on the power cover then remove the power cover.

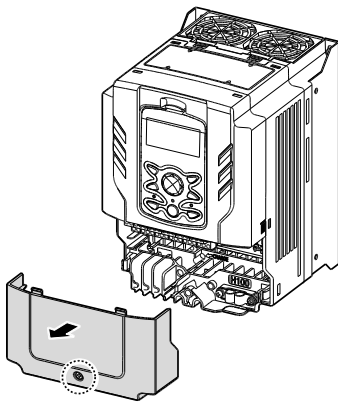

0.75–30 kW Models

110~185kW Models

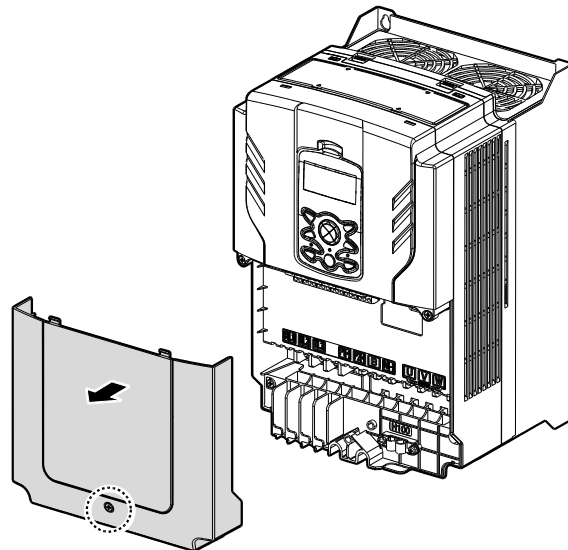

37–90 kW Models

220~500kW Models

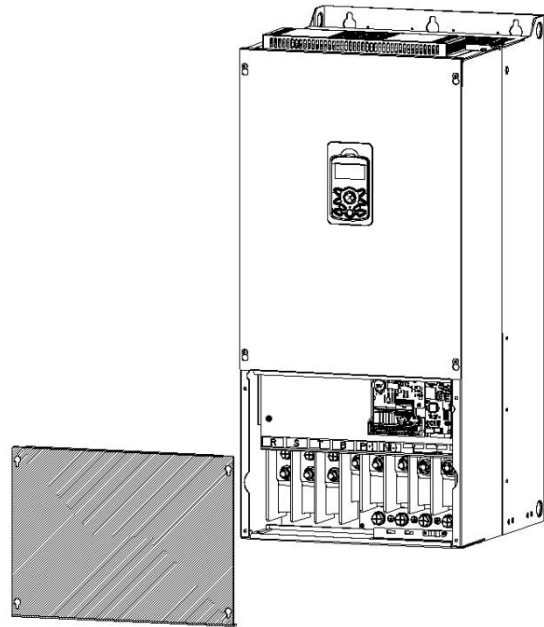
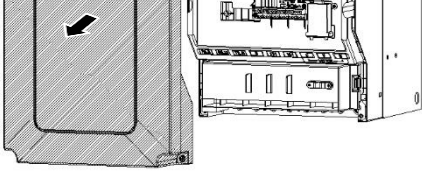

- 3 Remove the keypad from the inverter body.

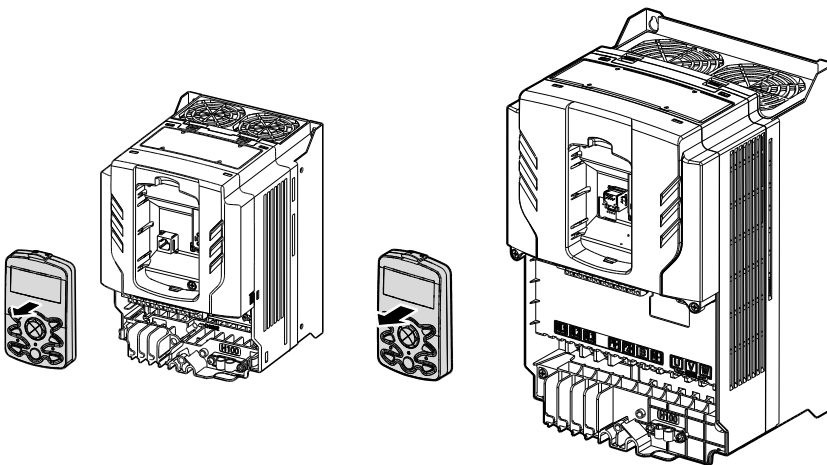

0.75–30 kW Models

37–90 kW Models

- 4 Loosen the screws securing the front cover, and remove the front cover by lifting it. The main PCB is exposed.

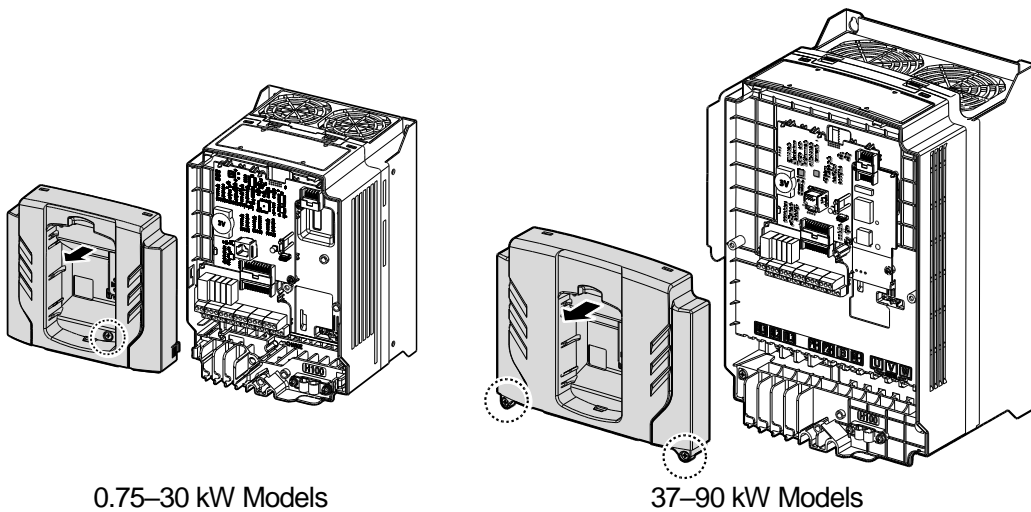

0.75–30 kW Models

37–90 kW Models

- 5 Locate the RTC battery holder on the I/O PCB, and remove the protective insulation strip by gently pulling it.

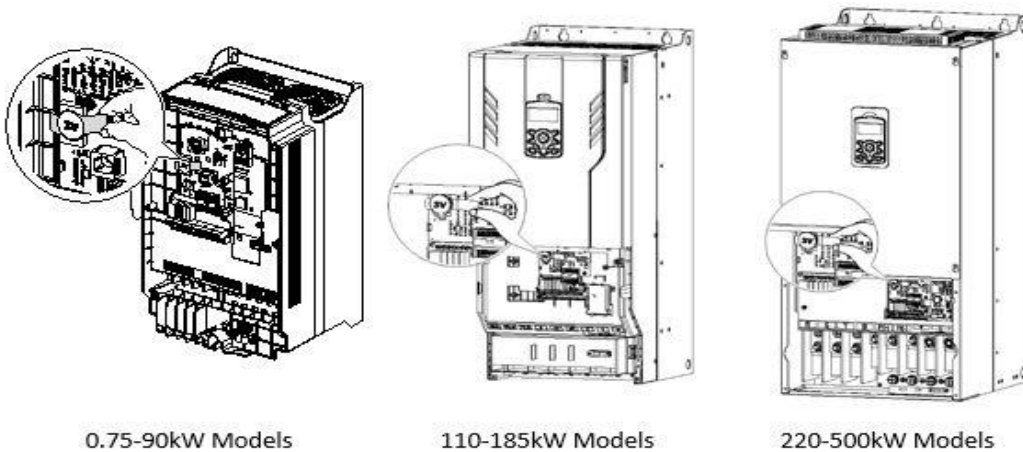

0.75–90kW Models

110–185kW Models

220–500kW Models

- 6 Reattach the front cover, the power cover, and the keypad back onto the inverter body
- 7 For detailed information on the RTC battery, refer to the battery specifications on page [541](#).

⚠ Caution

Ensure that the inverter is turned off and DC link voltage has dropped to a safe level before opening the terminal cover and installing the RTC battery.

2.3 Cable Wiring

Open the terminal cover, remove the cable guides, and then install the ground connection as specified. Complete the cable connections by connecting an appropriately rated cable to the terminals on the power and control terminal blocks.

Read the following information carefully before carrying out wiring connections to the inverter. All warning instructions must be followed.

⚠ Caution

- Install the inverter before carrying out wiring connections.
- Ensure that no small metal debris, such as wire clippings, remain inside the inverter. Metal debris in the inverter may cause inverter failure.
- Tighten terminal screws to their specified torque. Loose terminal block screws may allow the cables to disconnect and cause a short circuit or inverter failure. Refer to page [565](#).
- Do not place heavy objects on top of electric cables. Heavy objects may damage the cable and result in electric shock.
- Use cables with the largest cross-sectional area, appropriate for power terminal wiring, to ensure that voltage drops do not exceed 2%.
- Use copper cables rated at 600 V, 75 °C for power terminal wiring.
- Use copper cables rated at 300 V, 75 °C for control terminal wiring.
- If you need to re-wire the terminals due to wiring-related faults, ensure that the inverter keypad display is turned off and the charge lamp under the terminal cover is off before working on wiring connections. The inverter may hold a high voltage electric charge long after the power supply has been turned off.
- The accessible connections and parts listed below are of protective class 0. It means that the protection of these circuits relies only upon basic insulation and becomes hazardous in the event of a failure of the basic insulation. Therefore, devices connected to these circuits must provide electrical-shock protection as if the device was connected to supply mains voltage. In addition, during installation these parts must be considered, in relation with electrical-shock, as supply mains voltage circuits.

[Class 0 circuits]

➔ MULTI FUNCTION INPUT : P1-P7, CM

➔ ANALOG INPUT : VR, V1, I2, TI

➔ ANALOG OUTPUT : AO1, AO2, TO

- CONTACT : Q1, EG, 24,A1, C1, B1, A2~5, C2~5, S+, S-, SG

Step 1 Terminal Cover and Cable Guide

The terminal cover and cable guide must be removed to install cables. Refer to the following procedures to remove the covers and cable guide. The steps to remove these

parts may vary depending on the inverter model.

- 1 Loosen the bolt that secures the terminal cover. Then remove the cover by lifting it from the bottom and away from the front.

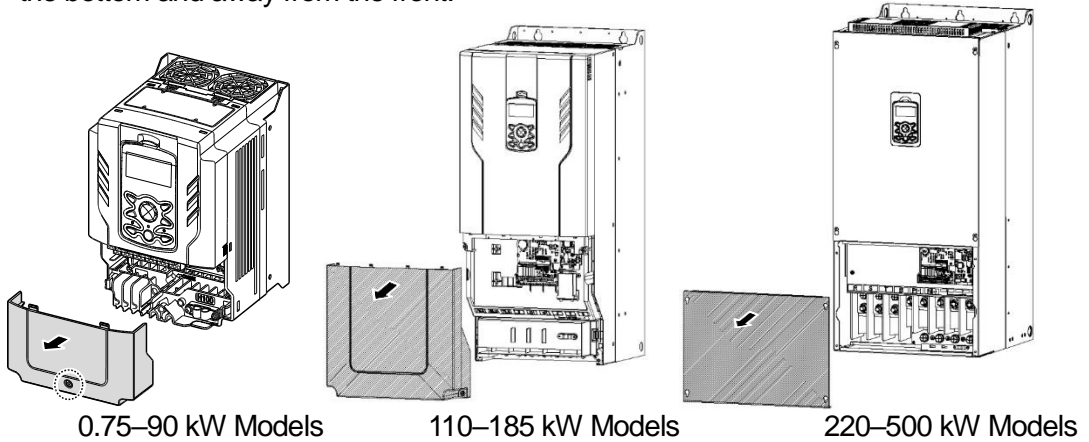

- 2 Push and hold the levers on both sides of the cable guide (❶) and then remove the cable guide by pulling it directly away from the front of the inverter (❷). In some models (37~90kW) where the cable guide is secured by a bolt, remove the bolt first.

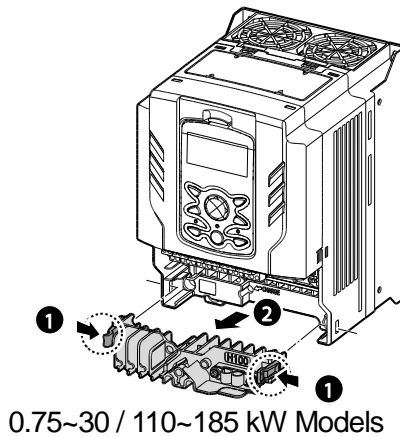

- 3 Connect the cables to the power terminals and the control terminals. For cable specifications, refer to 1.5 Cable Selection on page 14.

Step 2 Ground Connection

Remove the terminal cover(s) and cable guide. Then follow the instructions below to install the ground connection for the inverter.

- 1 Locate the ground terminal and connect an appropriately rated ground cable to the terminals. Refer to *1.5 Cable Selection* on page 14 to find the appropriate cable specification for your installation.

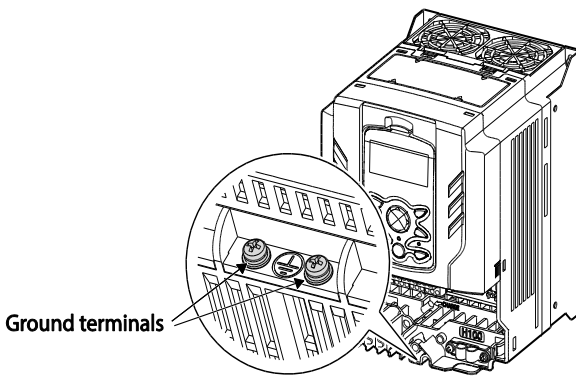

0.75–30 kW (3-Phase)

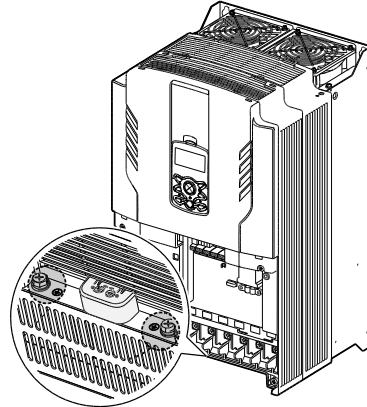

37–90 kW (3-Phase)

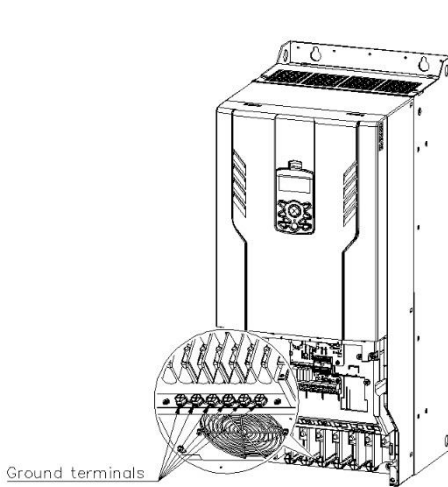

110–185kW (3-Phase)

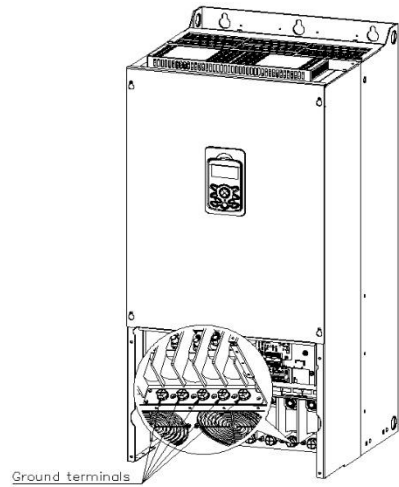

220-250kW (3-Phase)

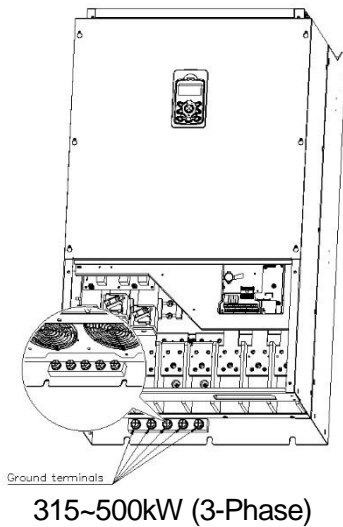

2 Connect the other ends of the ground cables to the supply earth (ground) terminal

Note

- 200 V products require Class 3 grounding. Resistance to ground must be $\leq 100 \Omega$.
- 400 V products require Special Class 3 grounding. Resistance to ground must be $\leq 10 \Omega$.

⚠ Warning

Install ground connections for the inverter and the motor by following the correct specifications to ensure safe and accurate operation. Using the inverter and the motor without the specified grounding connections may result in electric shock.

This product can cause a D.C current in the protective earthing conductor. If a RCD or monitoring (RCM) device is used for protection, only RCD or RCM of Type B is allowed on supply side of this product.

Step 3 Power Terminal Wiring

The following illustration shows the terminal layout on the power terminal block. Refer to the detailed descriptions to understand the function and location of each terminal before making wiring connections. Ensure that the cables selected meet or exceed the specifications in [1.5 Cable Selection](#) on page [14](#) before installing them.

⚠ Caution

- Apply rated torques to the terminal screws. Loose screws may cause short circuits and

malfunctions. Tightening the screw too much may damage the terminals and cause short circuits and malfunctions.

- Use copper wires only with 600 V, 75 °C rating for the power terminal wiring, and 300 V, 75 °C rating for the control terminal wiring.
- Power supply wirings must be connected to the R, S, and T terminals. Connecting them to the U, V, W terminals causes internal damages to the inverter. Motor should be connected to the U, V, and W Terminals. Arrangement of the phase sequence is not necessary.
- Equipment must only be fitted to the closed electric operating areas.

Attention

- Appliquer des couples de marche aux vis des bornes. Des vis desserrées peuvent provoquer des courts-circuits et des dysfonctionnements. Ne pas trop serrer la vis, car cela risque d'endommager les bornes et de provoquer des courts-circuits et des dysfonctionnements.
- Utiliser uniquement des fils de cuivre avec une valeur nominale de 600 V, 90 °C pour le câblage de la borne d'alimentation, et une valeur nominale de 300 V, 75 °C pour le câblage de la borne de commande.
- Les câblages de l'alimentation électrique doivent être connectés aux bornes R, S et T. Leur connexion aux bornes U, V et W provoque des dommages internes à l'onduleur. Le moteur doit être raccordé aux bornes U, V et W. L'arrangement de l'ordre de phase n'est pas nécessaire.

0.75–30 kW (3-Phase)

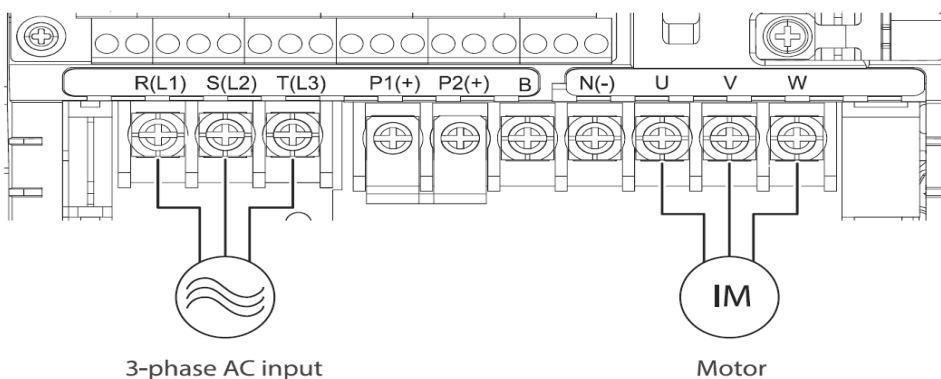
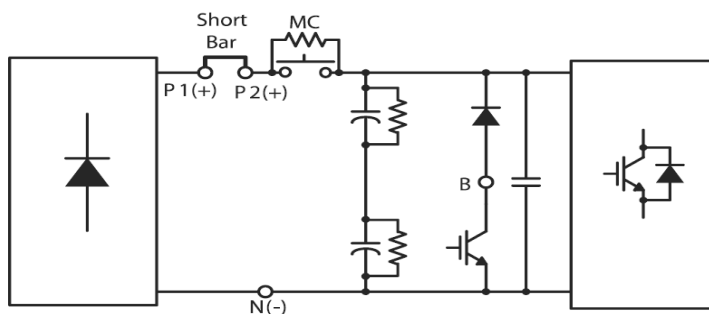

3-phase AC input

Motor

Power Terminal Labels and Descriptions

| Terminal Labels | Name | Description |
|-----------------------|--------------------------|--|
| R(L1) / S(L2) / T(L3) | AC power input terminal | Mains supply AC power connections. |
| P2(+)/ N(-) | DC link terminal | DC voltage terminals. |
| P1(+)/ P2(+) | DC Reactor terminal | DC Reactor wiring connection. (When you use the DC Reactor, must remove short-bar) |
| P2(+)/ B | Brake resistor terminals | Brake resistor wiring connection. |
| U / V / W | Motor output terminals | 3-phase induction motor wiring connections. |

37–90 kW (3-Phase)

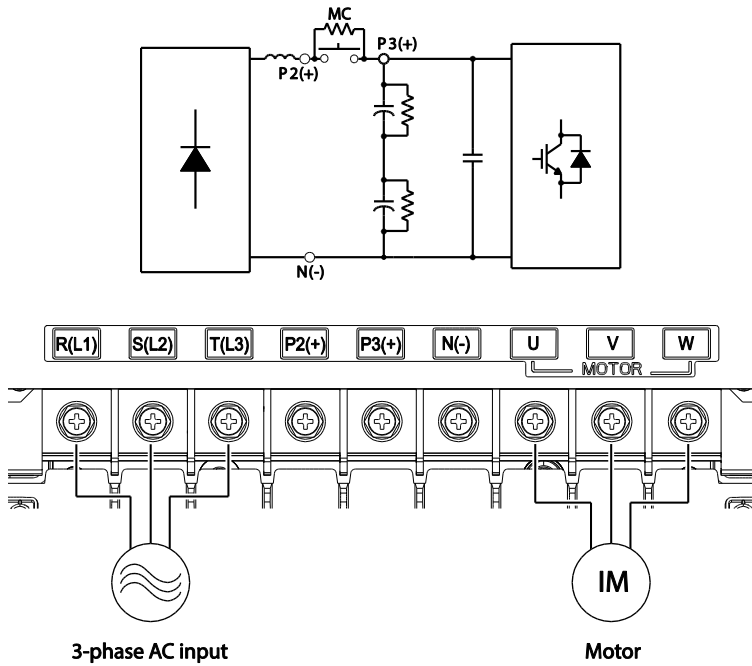

Power Terminal Labels and Descriptions

| Terminal Labels | Name | Description |
|-----------------------|-------------------------|---|
| R(L1) / S(L2) / T(L3) | AC power input terminal | Mains supply AC power connections. |
| P2(+)/ N(-) | DC link terminal | DC voltage terminals. |
| P3(+)/ N(-) | Brake unit terminals | Brake unit wiring connection. |
| U / V / W | Motor output terminals | 3-phase induction motor wiring connections. |

110–250kW (3-Phase)

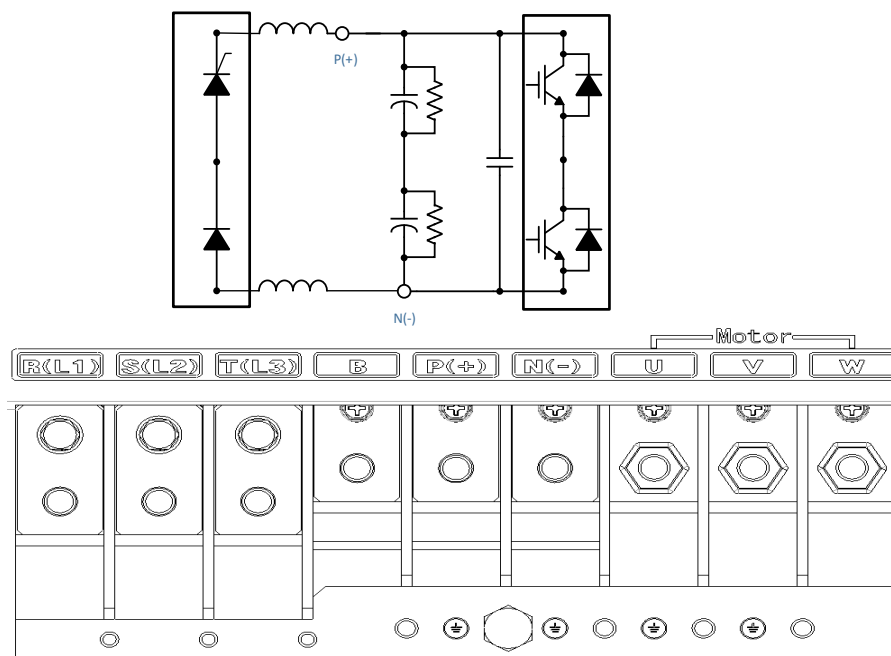

Power Terminal Labels and Descriptions

| Terminal Labels | Name | Description |
|-----------------------|--|---|
| R(L1) / S(L2) / T(L3) | AC power input terminal | Mains supply AC power connections. |
| B | - | It can not be used because it does not provide a braking module |
| P(+)/N(-) | DC link terminal (or Brake unit terminals) | DC voltage terminals. (or Brake unit wiring connection) |
| U / V / W | Motor output terminals | 3-phase induction motor wiring connections. |

315–500kW (3-Phase)

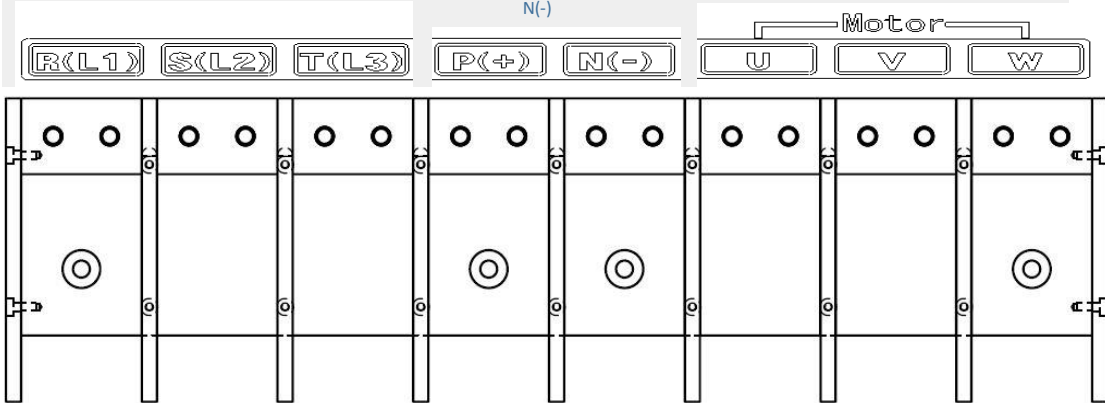
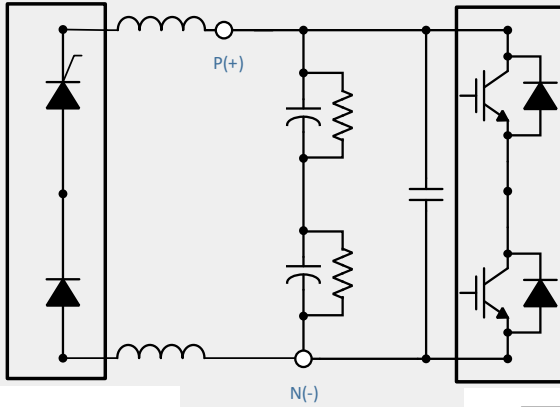

| Terminal Labels | Name | Description |
|-----------------------|---|--|
| R(L1) / S(L2) / T(L3) | AC power input terminal | Mains supply AC power connections. |
| P(+)/N(-) | DC link terminal (or Brake unit terminals) | DC voltage terminals. (or Brake unit wiring connection) |
| U / V / W | Motor output terminals | 3-phase induction motor wiring connections. |

Note

- Apply a DC input to the P2 (+) and N (-) terminals to operate the inverter on DC voltage input.
- Use STP (Shielded Twisted Pair) cables to connect a remotely located motor with the inverter. Do not use 3 core cables.
- Make sure that the total cable length does not exceed 492 ft (150 m). For inverters < = 3.7 kW capacity, ensure that the total cable length does not exceed 165 ft (50 m).
- Long cable runs can cause reduced motor torque in low frequency applications due to voltage drop. Long cable runs also increase a circuit’s susceptibility to stray capacitance and may trigger over-current protection devices or result in malfunction of equipment connected to the inverter.
- Voltage drop is calculated by using the following formula:
- Voltage Drop (V) = [$\sqrt{3}$ X cable resistance (mΩ/m) X cable length (m) X current (A)] / 1000
- Use cables with the largest possible cross-sectional area to ensure that voltage drop is minimized over long cable runs. Lowering the carrier frequency and installing a micro surge filter may also help to reduce voltage drop.

| Distance | < 165 ft (50 m) | < 330 ft (100 m) | > 330 ft (100 m) |
|---------------------------|-----------------|------------------|------------------|
| Allowed Carrier Frequency | <15 kHz | <5 kHz | <2.5 kHz |

 **Warning**

Do not connect power to the inverter until installation has been fully completed and the inverter is ready to be operated. Doing so may result in electric shock.

 **Caution**

- Power supply cables must be connected to the R, S, and T terminals. Connecting power cables to other terminals will damage the inverter.
- Use insulated ring lugs when connecting cables to R/S/T and U/V/W terminals.
- The inverter’s power terminal connections can cause harmonics that may interfere with other communication devices located near to the inverter. To reduce interference the installation of noise filters or line filters may be required.
- To avoid circuit interruption or damaging connected equipment, do not install phase-advanced condensers, surge protection, or electronic noise filters on the output side of the inverter.
- Connect the MC to the output of the inverter and avoid MC ON / OFF state during operation.
(It may cause inverter trip and burn-out.)

Step 4 Control Terminal Wiring

The illustrations below show the detailed layout of control wiring terminals and control board switches. Refer to the detailed information provided below and [1.5 Cable Selection](#) on page 14 before installing control terminal wiring and ensure that the cables used meet the required specifications.

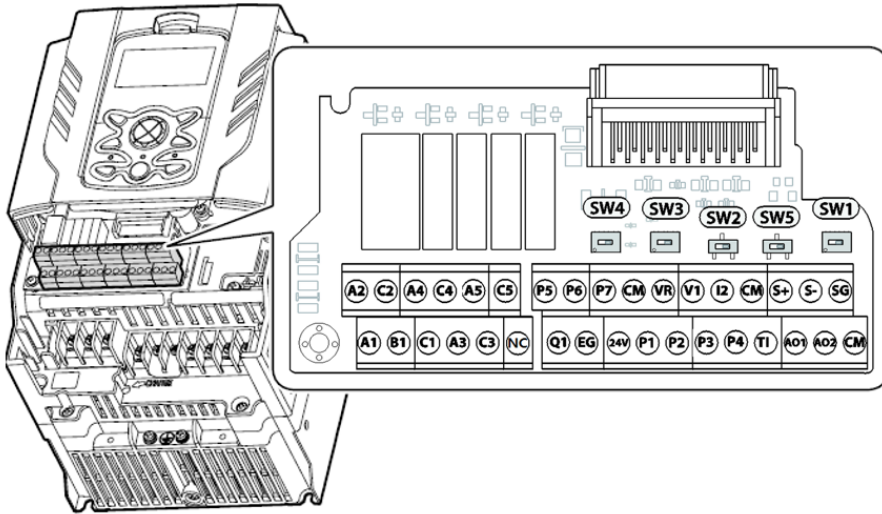

Switch Symbols and Description

| Switch | Description | Factory Default |
|--------|---|-----------------|
| SW1 | Terminating Resistor selection switch (Left: On, Right: Off) | Right: OFF |
| SW2 | NPN/PNP mode selection switch (Left: PNP, Right: NPN) | Right: NPN |
| SW3 | V1/T1 (PTC) mode selection switch (Left: V1, Right: T1) | Left: V1 |
| SW4 | analog voltage/current input terminal selection switch (Left: I2, Right: V2) | Left: I2 |
| SW5 | analog voltage/current output terminal selection switch (Left: VO, Right: IO) | Left: VO |

Input and Output Control Terminal Block Wiring Diagram

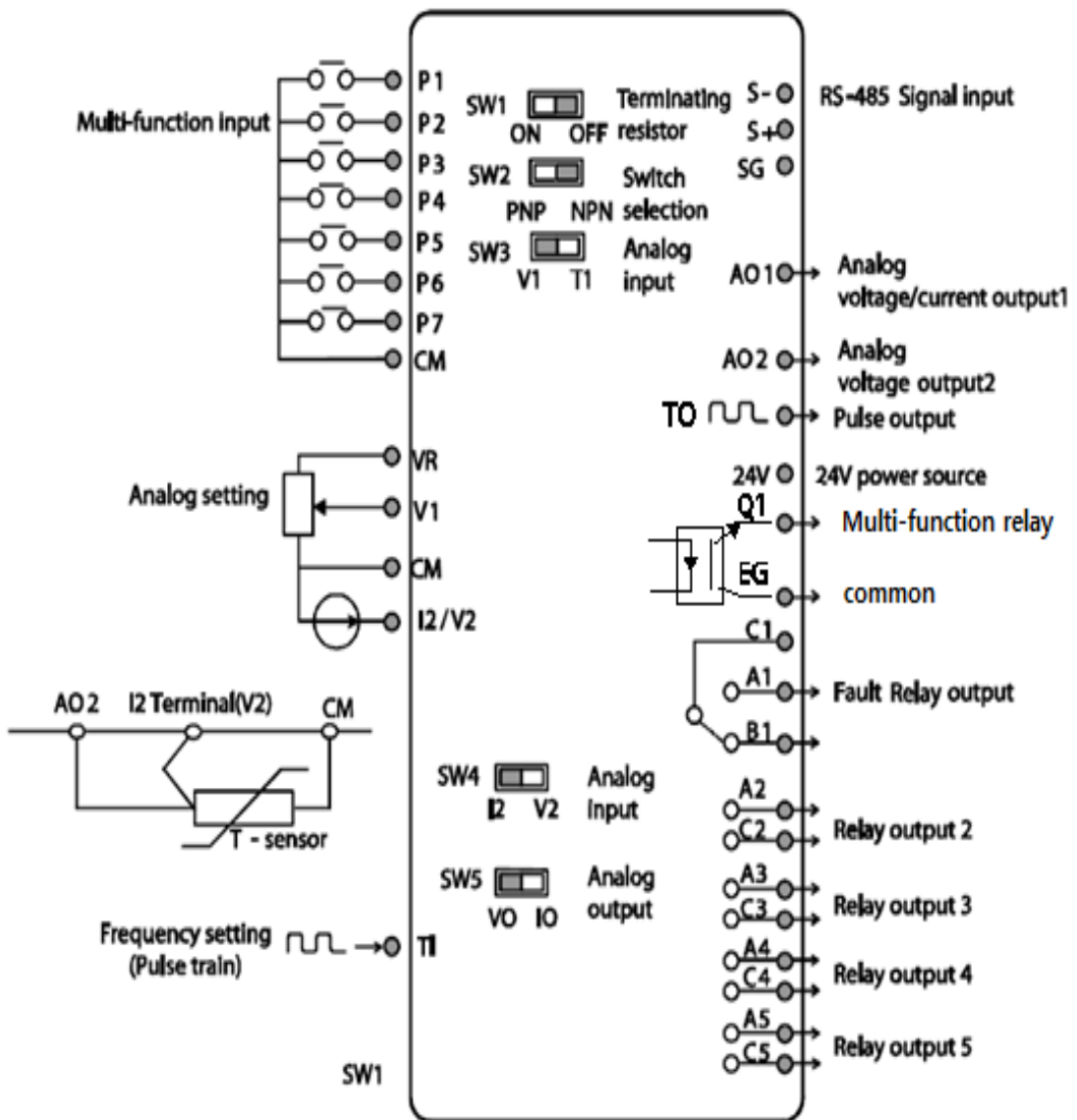

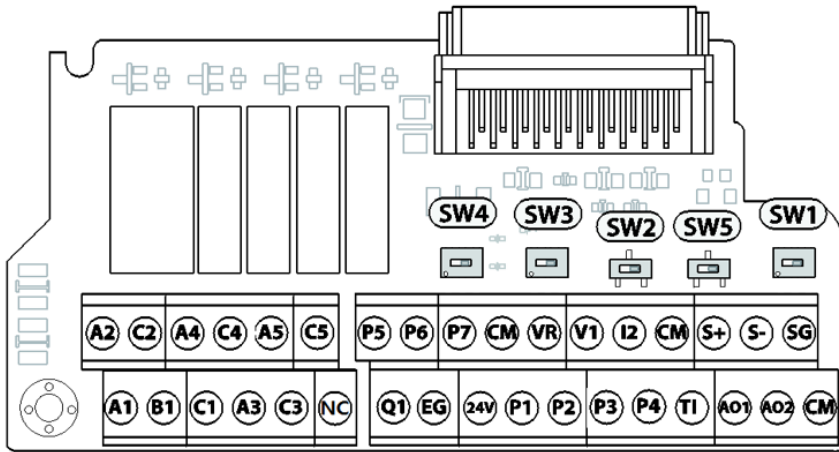

Input Terminal Labels and Descriptions

| Function | Label | Name | Description |
|---------------------------------------|-------|---------------------------------------|---|
| Multi-function terminal configuration | P1–P5 | Multi-function Input 1-7 | Configurable for multi-function input terminals. Factory default terminals and setup are as follows : P1: Fx P2: Rx P3: BX P4: RST P5: Speed-L P6: Speed-M P7: Speed-H |
| | CM | Common Sequence | Common terminal for contact input and analog input / output terminals. All three CM terminals are the same circuit. Please use it where wiring is easy. |
| Analog input configuration | VR | Potentiometer power supply | Used to setup or modify a frequency reference via analog voltage or current input. Maximum Voltage Output: 12 V Maximum Current Output: 12 mA Potentiometer : 1–10k Ω |
| | V1 | Voltage input for frequency reference | Used to setup or modify a frequency reference via analog voltage input terminal. Unipolar: 0–10 V(12 V Max) |

| Function | Label | Name | Description |
|----------|-------|---|--|
| | | | Bipolar: -10–10 V(±12 V Max) |
| | V2/I2 | Voltage/current input for frequency reference input | Used to setup or modify a frequency reference via analog voltage or current input terminals. Switch between voltage (V2) and current (I2) modes using a control board switch (SW4). Input current: 0–20 mA Maximum Input current: 24 mA Input resistance 249 Ω |
| | TI | Pulse input for frequency reference input (pulse train) | Setup or modify frequency references using pulse inputs from 0 to 32 kHz. Low Level: 0–0.8 V, High Level: 3.5–12 V |

Output/Communication Terminal Labels and Descriptions

| Function | Label | Name | Description |
|-------------------|-------|--|--|
| Analog output | AO | Voltage/Current Output | Used to send inverter output information to external devices: output frequency, output current, output voltage, or a DC voltage. Operate switch (SW5) to select the signal output type (voltage or current) at the AO terminal. Output Signal Specifications: Output voltage: 0–10 V Maximum output voltage/current: 12 V/10 mA Output current: 0–20 mA Maximum output current: 24 mA Factory default output: Frequency |
| Terminal Contacts | Q1 | Multi-function (Open Collector) Pulse Output | Selects a multi-function output signal or pulse output, output frequency, output current, output voltage, DC voltage by selecting one of the outputs. DC 26 V, 50 mA or less Pulse output terminal Output frequency: 0–32 kHz Output voltage: 0–12 V |
| | EG | Common | Common ground contact for an open collector (with external power source) |

| Function | Label | Name | Description |
|----------|----------------------------------|---------------------------------------|--|
| | 24 | 24 V power supply | -Maximum output current: 100 mA -Do not use this terminal for any purpose other than supplying power to a PNP mode circuit configuration (e.g. supplying power to other external devices). |
| | A1/C1/B1 | Fault relay output A,B contact | Sends out alarm signals when the inverter's safety features are activated. (N.O.: AC250 V \leq 2 A , DC 30 V \leq 3 A N.C.: AC250 V \leq 1 A , DC 30 V \leq 1 A) Fault condition: A1 and C1 contacts are connected (B1 and C1 open connection) Normal operation: B1 and C1 contacts are connected (A1 and C1 open connection) Factory default: Frequency |
| | A2/C2 A3/C3 A4/C4 A5/C5 | Multi-function relay output A contact | Defined in the inverter signal features such as output via the multi-function output terminal. (AC 250 V \leq 5 A, DC 30 V \leq 5 A). |
| | S+/S- /SG | RS-485 signal line | Used to send or receive RS-485 signals. Refer to 7RS-485 Communication Features on page 339 for more details. |

Note

- While making wiring connections at the control terminals ensure that the total cable length does not exceed 165 ft (50 m).
- Ensure that the length of any safety related wiring does not exceed 100 ft (30 m).
- Ensure that the cable length between the keypad and the inverter does not exceed 10 ft (3.04 m). Cable connections longer than 10 ft (3.04 m) may cause signal errors.
- Use ferrite material to protect signal cables from electro-magnetic interference.
- Take care when supporting cables using cable ties, to apply the cable ties no closer than 6 inches from the inverter. This provides sufficient access to fully close the terminal cover.

Step 5 PNP/NPN Mode Selection

The H100 inverter supports both PNP (Source) and NPN (Sink) modes for sequence inputs at the terminal. Select an appropriate mode to suit requirements using the PNP/NPN selection switch (SW2) on the control board. Refer to the following information for detailed applications.

PNP Mode (Source)

Select PNP using the PNP/NPN selection switch (SW2). Note that the factory default setting is NPN mode. CM is the common ground terminal for all analog inputs at the terminal, and P24 is 24 V internal source. If you are using an external 24 V source, build a circuit that connects the external source (-) and the CM terminal.

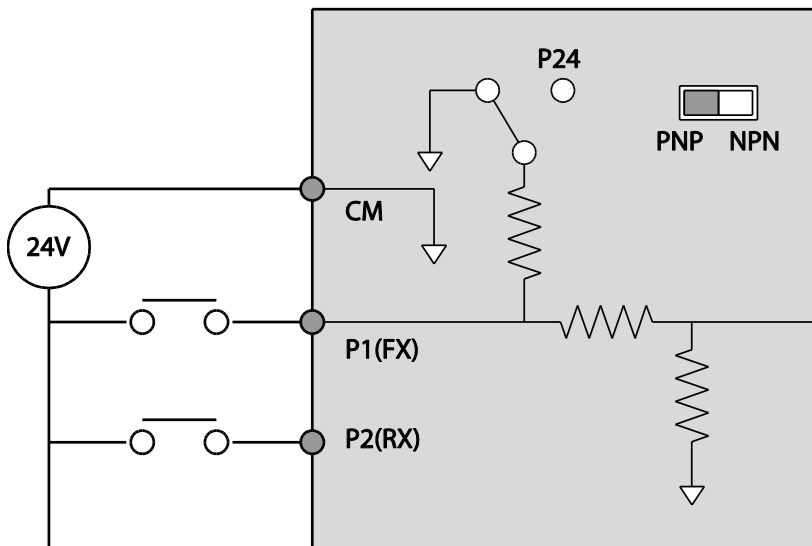

NPN Mode (Sink)

Select NPN using the PNP/NPN selection switch (SW2). Note that the factory default setting is NPN mode. CM is the common ground terminal for all analog inputs at the terminal, and P24 is 24 V internal source.

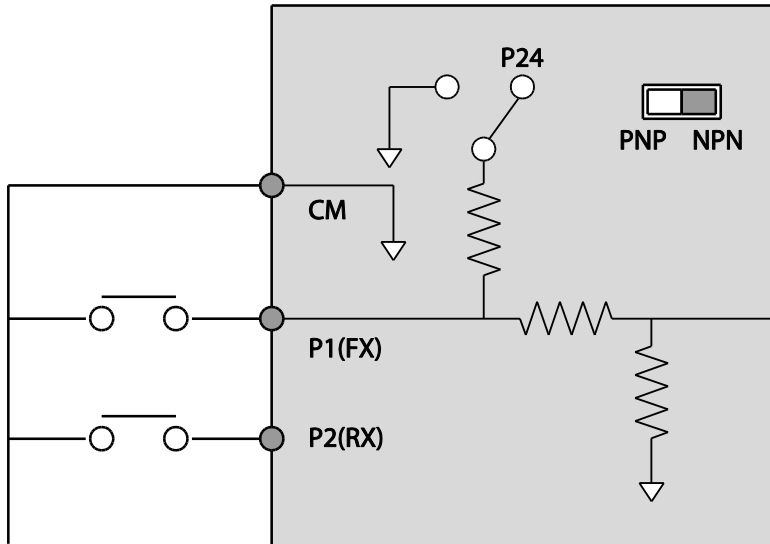

Step 6 Disabling the EMC Filter for Power Sources with Asymmetrical Grounding

H100, 400 V 0.75–55 kW, 110~500kW(3 phase) inverters have EMC filters built-in and activated as a factory default design. An EMC filter prevents electromagnetic interference by reducing radio emissions from the inverter. EMC filter use is not always recommended, as it increases leakage current. If an inverter uses a power source with an asymmetrical grounding connection, the EMC filter must be turned off.

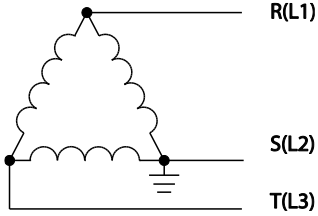
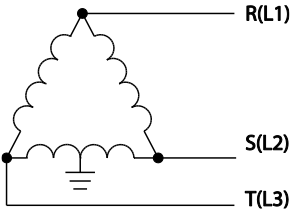
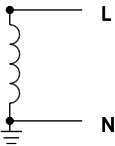
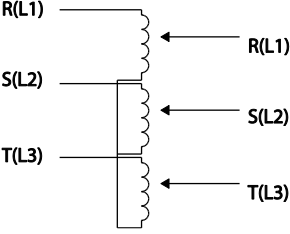
| Asymmetrical Grounding Connection | | | |
|--|--|--|---|
| One phase of a delta connection is grounded (TN Systems) |  | Intermediate grounding point on one phase of a delta connection (TN Systems) |  |
| The end of a single phase is grounded (TN Systems) |  | A 3-phase connection without grounding (TN Systems) |  |

⚠ Danger



- Do not activate the EMC filter if the inverter uses a power source with an asymmetrical grounding structure (corner-earthed systems), for example a grounded delta connection. Personal injury or death by electric shock may result.
- Wait at least 10 minutes before opening the covers and exposing the terminal connections. Before starting work on the inverter, test the connections to ensure all DC voltage has been fully discharged. Personal injury or death by electric shock may result.

Before using the inverter, confirm the power supply's grounding system. Disable the EMC filter if the power source has an asymmetrical grounding connection.

Disabling the Built-in EMC Filter for 0.75–30 kW (3-Phase) Inverters

Refer to the figures below to locate the EMC filter on/off terminal and replace the metal bolt with the plastic bolt. If the EMC filter is required in the future, reverse the steps and replace the plastic bolt with the metal bolt to reconnect the EMC filter.

If the EMC filter is required in the future, reverse the steps and replace the plastic bolt with the metal bolt to enable the EMC filter.

| Steel bolt | Plastic bolt |
|---|---|
|  |  |
| EMC ON | EMC OFF |

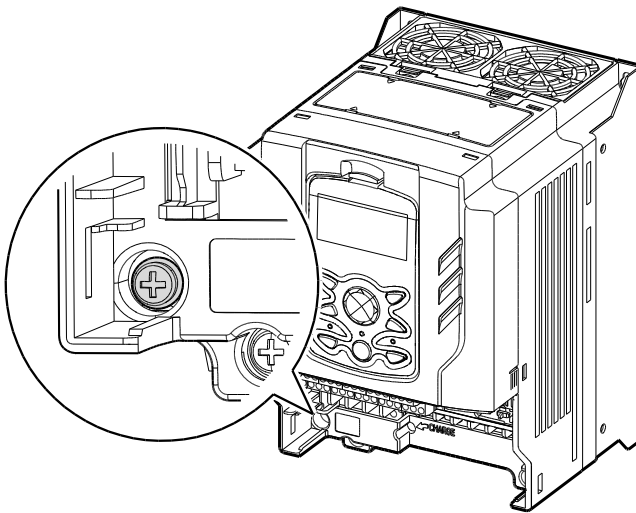

Disabling the Built-in EMC Filter for 37–55 kW (3–Phase) Inverters

Follow the instructions listed below to disable the EMC filters for the H100 inverters rated for 37–55 kW.

- 1 Remove the EMC ground cover located at the bottom of the inverter.

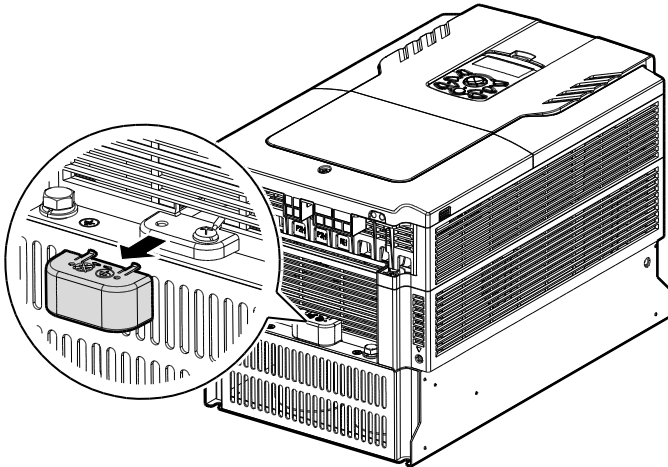

- 2 Remove the EMC ground cable from the right terminal (EMC filter-ON / factory default), and connect it to the left terminal (EMC filter-OFF / for power sources with asymmetrical grounding).

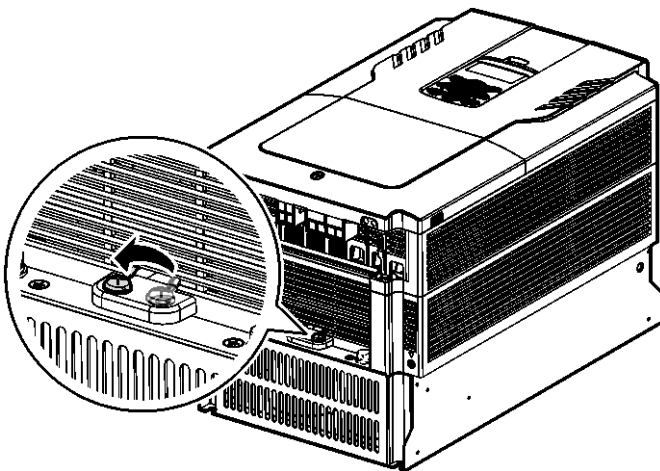

If the EMC filter is required in the future, reverse the steps and connect the EMC ground cable to the right terminal to enable the EMC filter.

Note

The terminal on the right is used to ENABLE the EMC filter (factory default). The terminal on the left is used to DISABLE the EMC filter (for power sources with asymmetrical grounding).

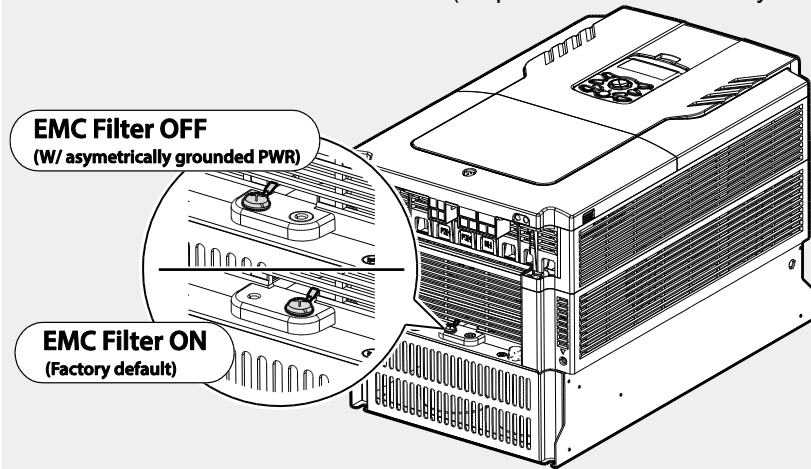

Disabling the Built-in EMC Filter for 110–500 kW (3–Phase) Inverters

Follow the instructions listed below to disable the EMC filters for the H100 inverters rated for 110–500 kW.

- 1 Remove the front cover located at the top of the inverter.
- 2 Remove the EMC ground cable from the right terminal (EMC filter-ON / factory default), and connect it to the left terminal (EMC filter-OFF / for power sources with asymmetrical grounding).

110–132 kW (3-Phase)

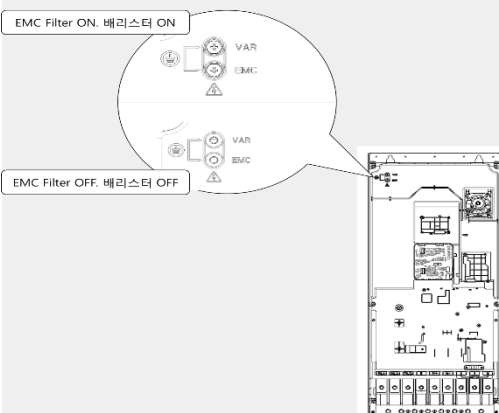

160–185 kW (3-Phase)

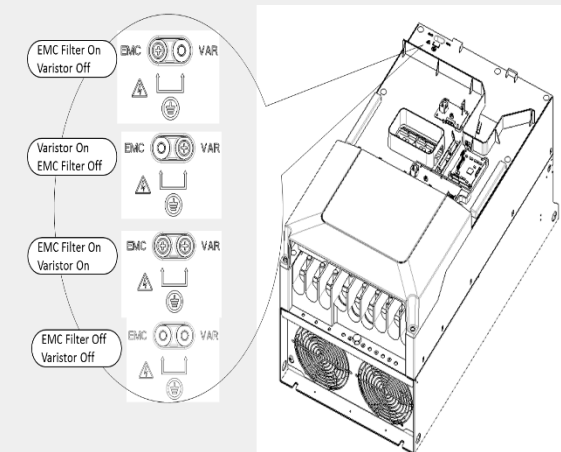

220–250 kW (3-Phase)

315–500 kW(3-Phase)

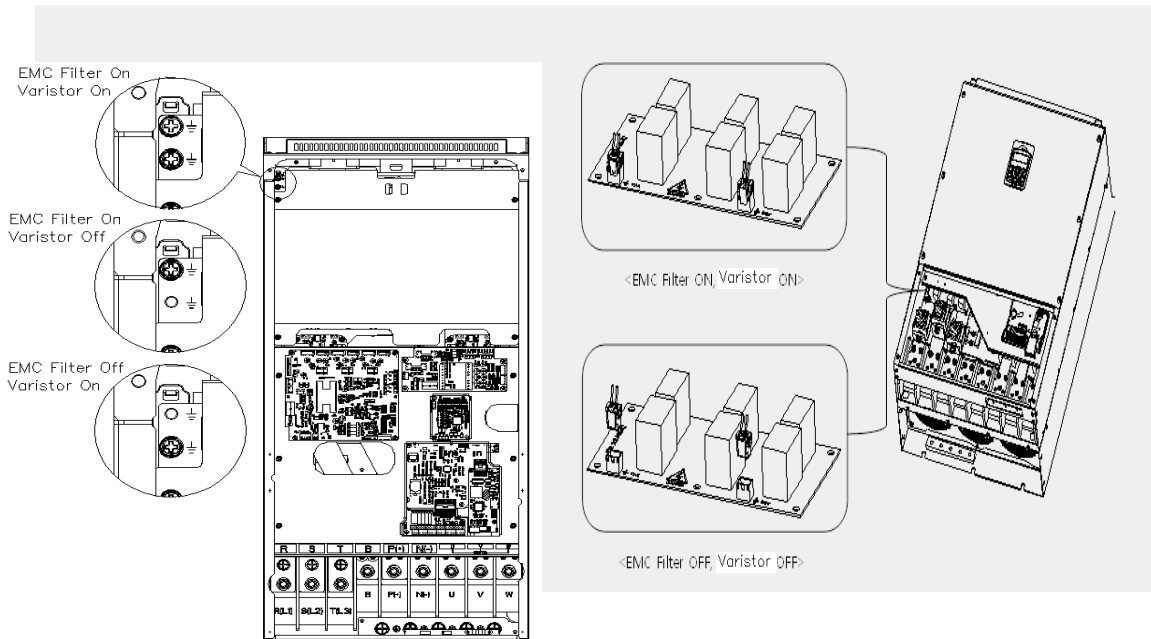

Step 7 Re-assembling the Covers and Routing Bracket

Re-assemble the cable routing bracket and the covers after completing the wiring and basic configurations. Note that the assembly procedure may vary according to the product group or frame size of the product.

2.4 Post-Installation Checklist

After completing the installation, check the items in the following table to make sure that the inverter has been safely and correctly installed.

| Items | Check Point | Ref. | Result |
|--|--|------------------------------|--------|
| Installation Location/Power I/O Verification | Is the installation location appropriate? | <u>p.10</u> | |
| | Does the environment meet the inverter's operating conditions? | <u>p.11</u> | |
| | Does the power source match the inverter's rated input? | <u>p.546</u> | |
| | Is the inverter's rated output sufficient to supply the equipment? (Degraded performance will result in certain circumstances. Refer to <u>11.8 Inverter Continuous Rated Current Derating</u> on page <u>578</u> for details.) | <u>p.546</u> | |
| Power Terminal Wiring | Is a circuit breaker installed on the input side of the inverter? | <u>p.18</u> | |
| | Is the circuit breaker correctly rated? | <u>p.561</u> | |
| | Are the power source cables correctly connected to the R/S/T terminals of the inverter? (Caution: connecting the power source to the U/V/W terminals may damage the inverter.) | <u>p.29</u> | |
| | Are the motor output cables connected in the correct phase rotation (U/V/W)? (Caution: motors will rotate in reverse direction if three phase cables are not wired in the correct rotation.) | <u>p.29</u> | |
| | Are the cables used in the power terminal connections correctly rated? | <u>p.14</u> | |
| | Is the inverter grounded correctly? | <u>p.27</u> | |
| | Are the power terminal screws and the ground terminal screws tightened to their specified torques? | <u>p.29</u> | |
| | Are the overload protection circuits installed correctly on the motors (if multiple motors are run using one inverter)? | - | |
| | Is the inverter separated from the power source by a magnetic contactor (if a braking resistor is in use)? | <u>p.18</u> | |

| Items | Check Point | Ref. | Result |
|-------------------------|---|--------------|--------|
| | Are advanced-phase capacitors, surge protection and electromagnetic interference filters installed correctly? (These devices MUST not be installed on the output side of the inverter.) | <u>p.29</u> | |
| Control Terminal Wiring | Are STP (shielded twisted pair) cables used for control terminal wiring? | - | |
| | Is the shielding of the STP wiring properly grounded? | - | |
| | If 3-wire operation is required, are the multi-function input terminals defined prior to the installation of the control wiring connections? | <u>p.36</u> | |
| | Are the control cables properly wired? | <u>p.36</u> | |
| | Are the control terminal screws tightened to their specified torques? | <u>p.21</u> | |
| | Is the total cable length of all control wiring < 165 ft (100 m)? | <u>p.40</u> | |
| | Is the total length of safety wiring < 100 ft (30 m)? | <u>p.40</u> | |
| Miscellaneous | Are optional cards connected correctly? | - | |
| | Is there any debris left inside the inverter? | <u>p.21</u> | |
| | Are any cables contacting adjacent terminals, creating a potential short circuit risk? | - | |
| | Are the control terminal connections separated from the power terminal connections? | - | |
| | Have the capacitors been replaced if they have been in use for > 2 years? | - | |
| | Has a fuse been installed for the power source? | <u>p.563</u> | |
| | Are the connections to the motor separated from other connections? | - | |

Note

STP (Shielded Twisted Pair) cable has a highly conductive, shielded screen around twisted cable pairs. STP cables protect conductors from electromagnetic interference.

2.5 Test Run

After the post-installation checklist has been completed, follow the instructions below to test the inverter.

- 1 Turn on the power supply to the inverter. Ensure that the keypad display light is on.
- 2 Select the command source.
- 3 Set a frequency reference, and then check the following:
 - If V1 is selected as the frequency reference source, does the reference change according to the input voltage at VR?
 - If V2 is selected as the frequency reference source, is the voltage/current selector switch (SW4) set to 'voltage', and does the reference change according to the input voltage?
 - If I2 is selected as the frequency reference source, is the voltage/current selector switch (SW4) set to 'current', and does the reference change according to the input current?
- 4 Set the acceleration and deceleration time.
- 5 Start the motor and check the following:
 - Ensure that the motor rotates in the correct direction (refer to the note below).
 - Ensure that the motor accelerates and decelerates according to the set times, and that the motor speed reaches the frequency reference.

Note

If the forward command (Fx) is on, the motor should rotate counterclockwise when viewed from the load side of the motor. If the motor rotates in the reverse direction, switch the cables at the U and V terminals.

Remarque

Si la commande avant (Fx) est activée, le moteur doit tourner dans le sens anti-horaire si on le regarde côté charge du moteur. Si le moteur tourne dans le sens inverse, inverser les câbles aux bornes U et V.

Verifying the Motor Rotation

- 1 On the keypad, set DRV-07 to '1 (Keypad)'.
- 2 Set a frequency reference.
- 3 If the inverter is in OFF mode, press the [AUTO] key twice on the keypad to operate the inverter in the forward (Fx) direction.
- 4 If the inverter is operating in AUTO mode, press the [AUTO] key once on the keypad to operate the inverter in the forward (Fx) direction.
- 5 Observe the motor's rotation from the load side and ensure that the motor rotates counterclockwise (forward).

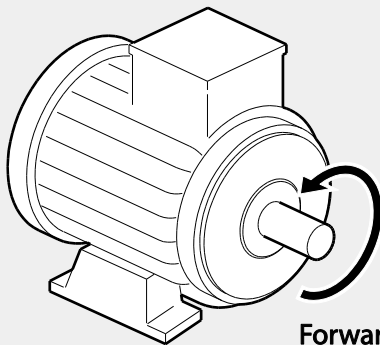
**⚠ Caution**

- Check the parameter settings before running the inverter. Parameter settings may have to be adjusted depending on the load.
- To avoid damaging the inverter, do not supply the inverter with an input voltage that exceeds the rated voltage for the equipment.
- Before running the motor at maximum speed, confirm the motor's rated capacity. As inverters can be used to easily increase motor speed, use caution to ensure that motor speeds do not accidentally exceed the motor's rated capacity.

3 Perform Basic Operations

This chapter describes the keypad layout and functions. It also introduces parameter groups and codes required to perform basic operations. The chapter also outlines the correct operation of the inverter before advancing to more complex applications. Examples are provided to demonstrate how the inverter actually operates.







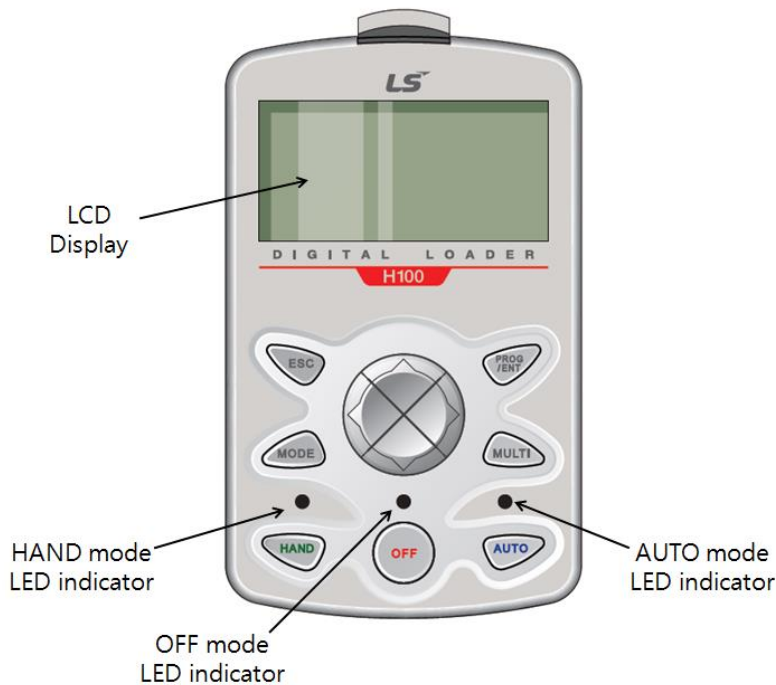

3.1 About the Keypad

The keypad is composed of two main components – the display and the operation (input) keys. Refer to the following illustration to identify part names and functions.

3.1.1 Operation Keys

The following table lists the names and functions of the keypad's operation keys.



| Key | Name | Description |
|---|---------------------------|--|
|  | [MODE] Key | Used to switch between modes. |
|  | [PROG / Ent] Key | Used to select, confirm, or save a parameter value. |
|  | [Up] key [Down] key | Switch between codes or increase or decrease parameter values. |
| | [Left] key [Right] key | Switch between groups or move the cursor during parameter setup or modification. |
|  | [MULTI] Key | Used to perform special functions, such as user code registration. |
|  | [ESC] Key | Used to cancel an input during parameter setup. Pressing the [ESC] key before pressing the [PROG / ENT] key reverts the parameter value to the previously set value. Pressing the [ESC] key while editing the codes in any function group makes the keypad display the first code of the function group. Pressing the [ESC] key while moving through the modes makes the keypad display Monitor mode. |
|  | [HAND] Key | Used to switch to HAND (local/manual) operation mode. |
|  | [OFF] Key | Used to switch to OFF (standby) mode or to reset the inverter faults. |
|  | [AUTO] Key | Used to switch to AUTO (remote) operation mode. |

3.1.2 About the Display

Monitor mode display

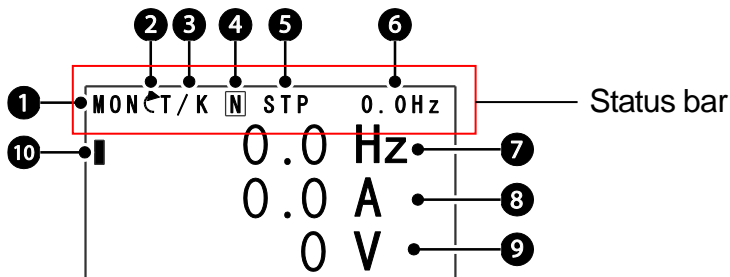

The following table lists display icons and their names/functions.

| No. | Name | Description |
|-----|--------------------------------------|--|
| 1 | Operation mode | Displays one of the following inverter modes: Mon: Monitor mode PAR: Parameter mode U&M: User defined and Macro mode TRP: Trip mode CNF: Config mode |
| 2 | Rotational direction | Displays the motor's rotational direction: - Fx or Rx. |
| 3 | Command Source / Frequency reference | Displays a combination of a command source and a frequency reference. Command source K: Keypad O: Optional Fieldbus module A: Application option E: Time event R: Built-in RS-485 communication T: Terminal block Frequency reference source K: Keypad V: V1 terminal X: I2 terminal P: Pulse terminal U: Up operation frequency (Up-down operation) D: Down operation frequency (Up-down operation) S: Stop operation frequency (Up-down operation) O: Optional Fieldbus module J: Jog frequency R: Built-in RS-485 frequency |

| No. | Name | Description |
|-----|---|---|
| | | 1–7: Multi-step frequency |
| 4 | Multi-function key (UserGrp SelKey) configuration | The multi function key (the [MULTI] key) on the keypad is used to register or delete User group parameters in Parameter mode. |
| 5 | Operating status | Displays one of the following operation states: STP: Stop FWD: Forward operation REV: Reverse operation C: Forward command given ↷: Reverse command given DC: DC output WAN: Warning STL: Stall SPS: Speed search OSS: S/W over current protection is on OSH: H/W overcurrent protection TUN: Auto tuning PHT: Pre-heat FIR: Fire mode operation SLP: Sleep mode operation LTS: Load tuning CAP: Capacity diagnostics PCL: Pump clean |
| 6 | Status display item | Status bar display item |
| 7 | Monitor mode item 1 | Monitor mode display item 1 |
| 8 | Monitor mode item 2 | Monitor mode display item 2 |
| 9 | Monitor mode item 3 | Monitor mode display item 3 |
| 10 | Monitor mode cursor | Used to highlight currently selected items. |

Parameter edit mode display

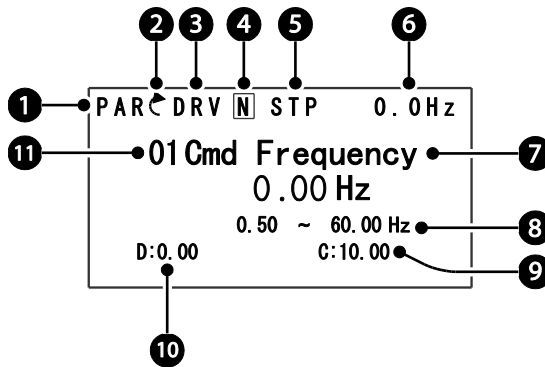

The following table lists display icons and their names/functions.

| No. | Name | Description |
|-----|--|---|
| 1 | Operation mode | Displays one of the following inverter modes: Mon: Monitor mode PAR: Parameter mode U&M: User defined and Macro mode TRP: Trip mode CNF: Config mode |
| 2 | Rotational direction | Displays the motor's rotational direction: - Fx or Rx. |
| 3 | Parameter group | Displays one of the following parameter group names: DRV: Drive group BAS: Basic group ADV: Advanced group CON: Control group IN: Input terminal group OUT: Output terminal group COM: Communication group PID: PID group EPI: External PID group AP1: Application 1 group AP2: Application 2 group AP3: Application 3 group PRT: Protection function group M2: 2nd motor group |
| 4 | Multi-function key (UserGrp SelKey)configuration | Used to register or delete User group parameters in Parameter mode. |

| No. | Name | Description |
|-----|-------------------|---|
| 5 | Operating status | Displays one of the following operation states: STP: Stop FWD: Forward operation REV: Reverse operation C: Forward command given ʁ: Reverse command given DC: DC output WAN: Warning STL: Stall SPS: Speed search OSS: S/W over current protection is on OSH: H/W overcurrent protection TUN: Auto tuning PHT: Pre-heat FIR: Fire mode operation SLP: Sleep mode operation LTS: Load tuning CAP: Capacity diagnostics PCL: Pump clean |
| 6 | Display item | Displays the value of a monitor display item selected at CNF-20 (Anytime Para). |
| 7 | Parameter value | Displays the parameter value of currently selected code. |
| 8 | Setting range | Displays the value range for the selected parameter. |
| 9 | Set value | Displays the currently set value for the code. |
| 10 | Default | Displays the factory default value for the code. |
| 11 | Code no. and name | Displays the number and name of the currently selected code. |

3.1.3 Display Modes

The H100 inverter uses 5 modes to monitor or configure different functions. The parameters in Parameter mode and User & Macro mode are divided into smaller groups of relevant functions.

Press the [MODE] key to navigate between groups

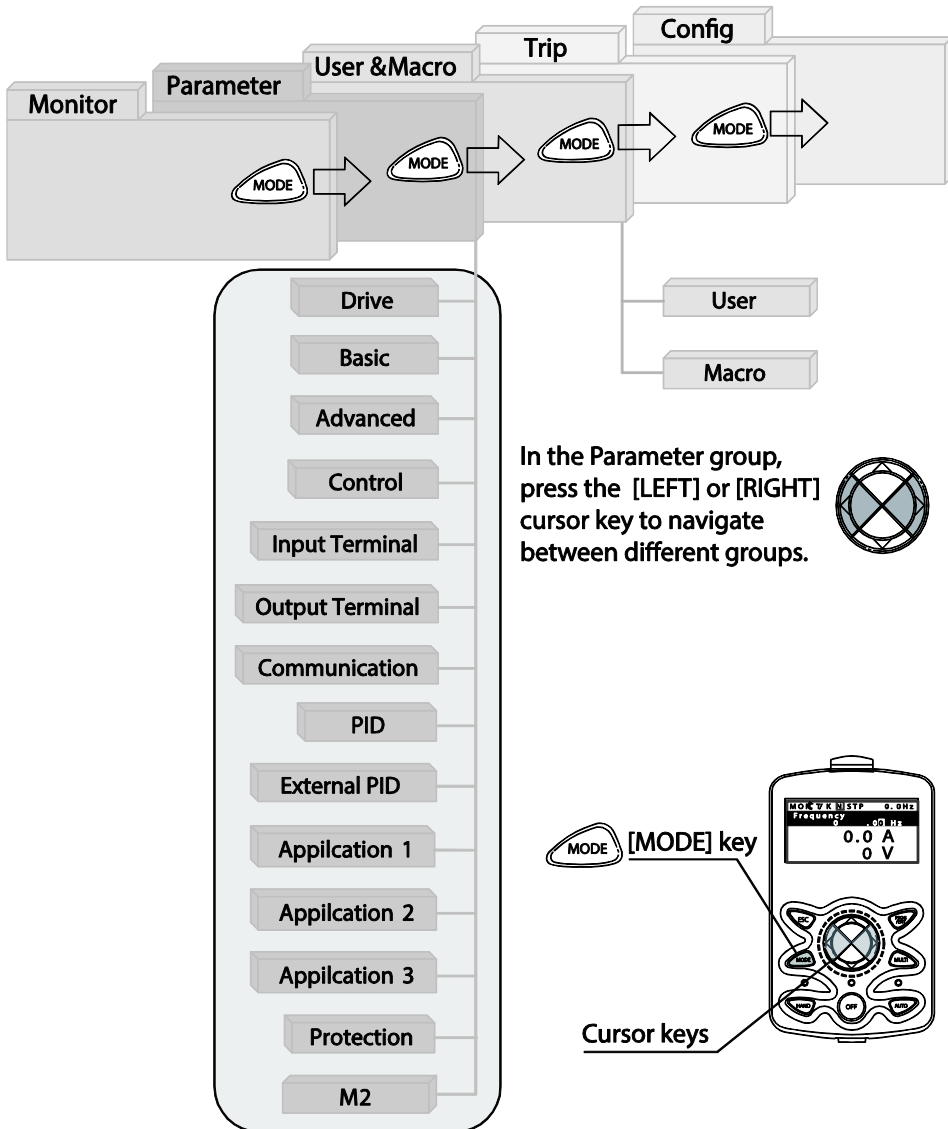

Table of Display Modes

The following table lists the 5 display modes used to control the inverter functions.

| Mode Name | Keypad Display | Description |
|-------------------|----------------|--|
| Monitor mode | MON | Displays the inverter's operation status information. In this mode, information including the inverter's frequency reference, operation frequency, output current, and voltage may be monitored. |
| Parameter mode | PAR | Used to configure the functions required to operate the inverter. These functions are divided into 14 groups based on purpose and complexity. |
| User & Macro mode | U&M | Used to define User groups and Macro groups. These user-definable groups allow specific functions of the inverter to be grouped and managed in separate groups. This mode is not displayed when you navigate through the modes if no user groups or Macro groups have been defined. |
| Trip mode | TRP | Used to monitor the inverter's fault trip information, including the previous fault trip history. When a fault trip occurs during inverter operation, the operation frequency, output current, and output voltage of the inverter at the time of the fault may be monitored. This mode is not displayed if the inverter is not at fault and fault trip history does not exist. |
| Config mode | CNF | Used to configure the inverter features that are not directly related to the operation of the inverter. The settings you can configure in the Config mode include keypad display language options, monitor mode environment settings, communication module display settings, and parameter duplication and initialization. |

Parameter Setting Mode

The following table lists the functions groups under Parameter mode.

| Function Group Name | Keypad Display | Description |
|---------------------------|----------------|---|
| Drive | DRV | Configures basic operation parameters. These include jog operation, motor capacity evaluation, and torque boost. |
| Basic | BAS | Configures basic operation parameters. These parameters include motor parameters and multi-step frequency parameters. |
| Advanced | ADV | Configures acceleration or deceleration patterns, frequency limits, energy saving features, and, regeneration prevention features. |
| Control | CON | Configures the features related to speed search and KEB (kinetic energy buffering). |
| Input Terminal | IN | Configures input terminal-related features, including digital multi-functional inputs and analog inputs. |
| Output Terminal | OUT | Configures output terminal-related features, including digital multi-functional outputs and analog outputs. |
| Communication | COM | Configures the USB-related features and communication features for the RS-485, Modbus-RTU, LS Bus, Metasys N2, and BACnet. Optional communication module related features may be configured as well, if one is installed. |
| PID process | PID | Configures the PID control-related features. |
| EPID process | EPI | Configures the external PID control-related features. |
| Application 1 | AP1 | Configures the Sleep Boost, SoftFill, and Multiple motor control (MMC) features related to the PID control. |
| Application 2 | AP2 | Configures the HVAC features by setting the features such as load tuning, pump cleaning, and pay back counter. |
| Application 3 | AP3 | Configures the time event-related features. |
| Protection | PRT | Configures motor and inverter protection features. |
| Motor 2 (Secondary motor) | M2 | Configures the secondary motor-related features. |

User & Macro Mode

| Function Group Name | Keypad Display | Description |
|---------------------|----------------|---|
| User | USR | Used to put the frequently accessed function parameters together into a group. User parameter groups can be configured using the multi-function key on the keypad. |
| Macro | MCx | Provides different factory-preset groups of functions based on the type of load. Groups MC1, MC2, or MC3 is displayed when the user selects the type of desired load. Macro groups can be selected in CNF mode. |

3.2 Learning to Use the Keypad

The keypad enables movement between groups and codes. It also enables users to select and configure functions. At code level, you can set parameter values to turn specific functions on or off or decide how the functions will be used. For detailed information on the codes in each function group, refer to 8 *Table of Functions* on page 392. Confirm the correct values (or the correct range of the values), then follow the examples below to configure the inverter with the keypad.

3.2.1 Display Mode Selection

The following figure illustrates how the display modes change when you press the [Mode] button on the keypad. You can continue to press the [Mode] key until you get to the desired mode.

User & Macro mode and Trip mode are not displayed when all the inverter settings are set to the factory default (User & Macro mode must be configured before it is displayed on the keypad, and Trip mode is displayed only when the inverter is at fault, or has previous trip fault history).

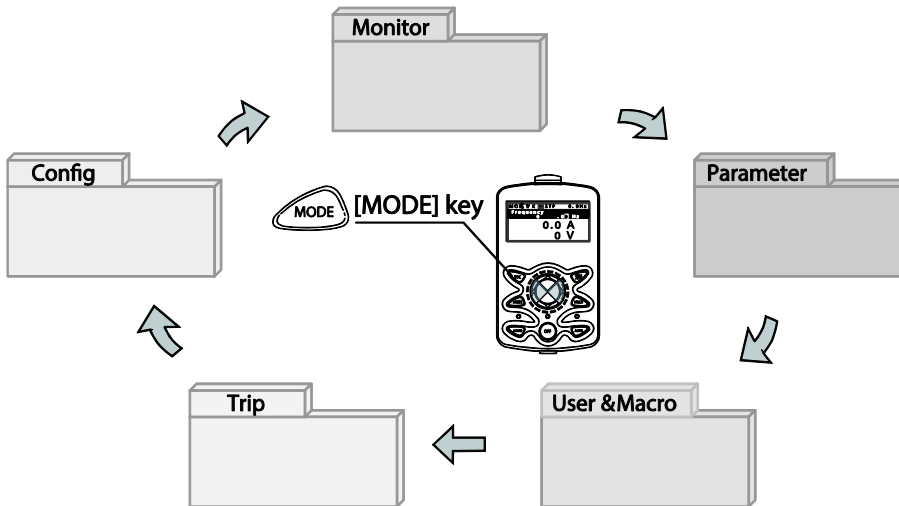

3.2.2 Operation Modes

The inverter is operable only when it is in HAND or AUTO mode. HAND mode is for local control using the keypad, while AUTO mode is for remote control via communication. On the other hand, the inverter stops operating when it is in OFF mode. Select one of the modes (HAND / AUTO / OFF) to operate the inverter or stop the operation.

Follow the examples below to learn how to switch between operation modes.

Operating the Inverter in HAND mode

- 1 Turn on the inverter. The inverter enters OFF mode and the OFF LED turns on.
- 2 Move to Parameter mode and set DRV-07 (frequency reference) to '0 (keypad)'.
- 3 Press the [HAND] key to enter HAND mode (local control mode). HAND mode LED turns on (the OFF LED turns off) and the inverter begins to operate.
- 4 Press the [OFF] key to stop the inverter operation. The inverter stops operating and the OFF LED turns on.

Operating the inverter in AUTO Mode

- 1 In OFF mode (when the OFF LED is on), move to Parameter mode and configure the command source at DRV-07 (frequency reference source).
- 2 Press the [AUTO] key to enter AUTO mode. In AUTO mode, the inverter operates based on the input from the command source set at DRV-07. For example, if DRV-07 (frequency reference source) is set to '0 (Keypad)', the frequency reference is set, and the run command is set to 'ON', the inverter starts operating as soon as the [AUTO] key on the keypad is pressed.
- 3 Press the [Auto] key again to stop the inverter operation using the keypad. In AUTO mode, the inverter begins or stops operating when the [AUTO] key is pressed.

Note

- You can stop the inverter operation by pressing the [OFF] key when the command source is set to 'Keypad.' In this case, however, the inverter enters OFF mode from AUTO mode.
- If the network communication is set as the command source, the inverter is operable only in AUTO mode. For example, if the run command is set to 'ON' via the network communication and the inverter is in OFF mode, the [AUTO] key must be pressed to start the inverter operation.
- The inverter is operable only in HAND and AUTO modes, but the Fire mode functions operate even when the inverter is in OFF mode.

3.2.3 Switching between Groups in Parameter Display Mode

After entering Parameter mode from Monitor mode, press the [Right] key to move to the next code. Press the [Left] key to go back to the previous code.

| | |
|--|---|
| <pre> MONCT/K N STP 0.0Hz Frequency 0.00 Hz 0.0 A 0 V </pre> | <p>The keypad OFF LED is turned OFF, and the keypad displays Monitor mode.</p> <ul style="list-style-type: none"> Press the [Mode] key to change the mode. |
| <pre> PARDRV N STP 0.0Hz 00 Jump Code 9 CODE 01 Cmd Frequency 0.00 Hz 02 Keypad Run Dir Forward </pre> | <p>Parameter mode is displayed.</p> <ul style="list-style-type: none"> The Drive group is currently selected. Press the [Right] key. |
| <pre> PARBAS N STP 0.0Hz 00 Jump Code 20 CODE 01 Aux Ref Src None 04 Cmd 2nd Src FX/RX-1 </pre> | <ul style="list-style-type: none"> The Basic group is selected. Press the [Right] key. |
| <pre> PARADV N STP 0.0Hz 00 Jump Code 24 CODE 01 Acc Pattern Linear 02 Dec Pattern Linear </pre> | <ul style="list-style-type: none"> The Advanced group is selected. Press the [Right] key 9 times. |
| <pre> PARPRT N STP 0.0Hz 00 Jump Code 40 CODE 05 Phase Loss Chk 06 IPO V Band 15 V </pre> | <ul style="list-style-type: none"> The Protection group is selected. Press the [Right] key. |

```

PAR←DRV [N] STP 0.0Hz
00 Jump Code          9 CODE
01 Cmd Frequency      0.00 Hz
02 Keypad Run Dir     Forward
    
```

- The Drive group is selected again.

3.2.4 Switching between Groups in User & Macro Mode

User & Macro mode is accessible only when the user codes are registered or when the macro features are selected. Refer to [8.16 Macro Groups](#) on page [494](#) for details about user code registration or macro group selection. After registering the user codes, or selecting a macro group, follow the examples below to access the User & Macro group.

```

MON←T/K [N] STP 0.0Hz
Frequency          0.00 Hz
0.0 A
0 V
    
```

- Monitor mode is displayed on the keypad.
- Press the [MODE] key twice.

```

U&M←USR [N] STP 0.0Hz
00 Jump Code          1 CODE
01 Cmd Frequency      0.00 Hz
02 Acc Time           20.0 sec
    
```

- User (USR) group in User & Macro mode is displayed.
- Press the [Right] key.

```

U&M←MC2 [N] STP 0.0Hz
00 Jump Code          1 CODE
01 Freq Ref Src       Keypad-1
02 Power-on Run       ----- No -----
    
```

- The Macro (MC2) group in User & Macro mode is displayed.
- Press the [Right] key.

```

U&M←USR [N] STP 0.0Hz
00 Jump Code          1 CODE
01 Cmd Frequency      0.00 Hz
02 Acc Time           20.0 sec
    
```

- User (USR) group in User & Macro mode is displayed again.

3.2.5 Navigating through the Codes (Functions)

Code Navigation in Monitor mode

The display items in Monitor mode are available only when the inverter is in AUTO mode. In Monitor mode, press the [Up] or [Down] key to move the cursor up or down. Different values, such as the operating frequency, the output current, or voltage are displayed according to the cursor position. The cursor does not move up or down in HAND mode or in OFF mode.

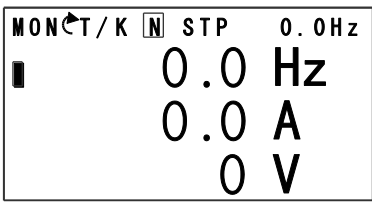
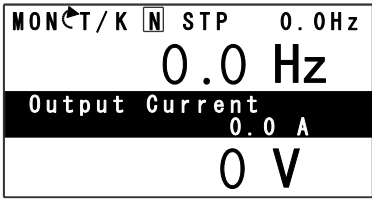
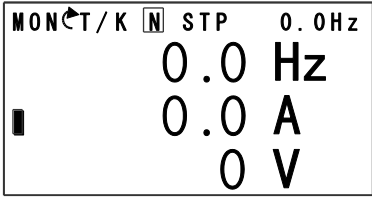
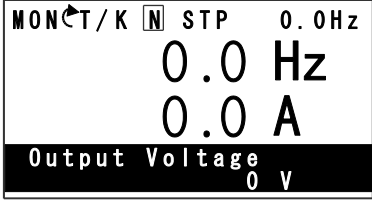
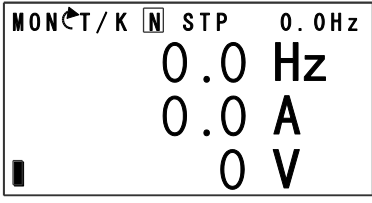
| | |
|--|---|
|  <p>MON ← T / K [N] STP 0.0 Hz 0.0 Hz 0.0 A 0 V</p> | <ul style="list-style-type: none"> • In AUTO mode, the cursor appears to the left of the frequency information. • Press the [Down] key. |
|  <p>MON ← T / K [N] STP 0.0 Hz 0.0 Hz Output Current 0.0 A 0 V</p> | <ul style="list-style-type: none"> • Information about the second item in Monitor mode (Output Current) is displayed. • Wait for 2 seconds until the information on the display disappears. |
|  <p>MON ← T / K [N] STP 0.0 Hz 0.0 Hz 0.0 A 0 V</p> | <ul style="list-style-type: none"> • Information about the second item in Monitor mode (Output Current) disappears and the cursor reappears to the left of the second item. • Press the [Down] key. |
|  <p>MON ← T / K [N] STP 0.0 Hz 0.0 Hz 0.0 A Output Voltage 0 V</p> | <ul style="list-style-type: none"> • Information about the third item in Monitor mode (Output Voltage) is displayed. • Wait for 2 seconds until the information on the display disappears. |
|  <p>MON ← T / K [N] STP 0.0 Hz 0.0 Hz 0.0 A 0 V</p> | <ul style="list-style-type: none"> • Information about the third item in Monitor mode (Output Voltage) disappears and the cursor appears to the left of the third item. • Press the [Up] key twice. |

| | | | | | |
|-----------|---|-----|-----|-----|---------|
| MON | ← | T/K | [N] | STP | 0.0Hz |
| Frequency | | | | | 0.00 Hz |
| 0.0 A | | | | | 0 V |

- Information about the first item in Monitor mode (Frequency) is displayed.
- Wait for 2 seconds until the information on the display disappears.

| | | | | | |
|-----|--------|-----|-----|-----|-------|
| MON | ← | T/K | [N] | STP | 0.0Hz |
| █ | 0.0 Hz | | | | |
| | 0.0 A | | | | |
| | 0 V | | | | |

- Information about the first item in Monitor mode (Frequency) disappears and the cursor appears to the left of the first item.
- Press the [Up] or [Down] key to move to a desired item and view the information.

Code Navigation in Parameter mode

The following examples show you how to move through codes in different function groups (Drive group and Basic group) in Parameter mode. In Parameter mode, press the [Up] or [Down] key to move to the desired functions.

| | |
|---|--|
| <pre> MONCT/K N STP 0.0Hz Frequency 0.00 Hz 0.0 A 0 V </pre> | <ul style="list-style-type: none"> • Display turns on when the inverter is powered on. Monitoring mode is displayed. • Press the [MODE] key. |
| <pre> PAR DRV N STP 0.0Hz 00 Jump Code 9 CODE 01 Cmd Frequency 0.00 Hz 02 Keypad Run Dir Forward </pre> | <ul style="list-style-type: none"> • Drive group (DRV) in Parameter mode is displayed. The first code in the Drive group (DRV 00 Jump Code) is currently selected. • If any other group is displayed, press the [MODE] key until the Drive group is displayed, or press the [ESC] key. |
| <pre> PAR DRV N STP 0.0Hz 00 Jump Code 9 CODE 01 Cmd Frequency 0.00 Hz 02 Keypad Run Dir Forward </pre> | <ul style="list-style-type: none"> • Press the [Down] key to move to the second code (DRV 01) of the Drive group. • Press the [Right] key to move to the next function group. |
| <pre> PAR BAS N STP 0.0Hz 00 Jump Code 20 CODE 01 Aux Ref Src None 04 Cmd 2nd Src FX/RX-1 </pre> | <ul style="list-style-type: none"> • The Basic group (BAS) is displayed. • Press the [Up] or [Down] key to move to the desired codes and configure the inverter functions. |

3.2.6 Navigating Directly to Different Codes

Parameter mode, User & Macro mode, and Config mode allow direct jumps to specific codes. The code used for this feature is called the Jump Code. The Jump Code is the first code of each mode. The Jump Code feature is convenient when navigating for a code in a function group that has many codes.

The following example shows how to navigate directly to code DRV- 09 from the initial code (DRV-00 Jump Code) in the Drive group.

| | |
|--|---|
| <pre> PAR DRV N STP 0.0Hz 00 Jump Code 9 CODE 01 Cmd Frequency 0.00 Hz 02 Keypad Run Dir Forward </pre> | <ul style="list-style-type: none"> The Drive group (DRV) is displayed in Parameter mode. Make sure that the first code in the Drive group (DRV 00 Jump Code) is currently selected. Press the [PROG/ENT] key. |
| <pre> PAR DRV N STP 0.0Hz 01 Jump Code CODE 1~99 CODE D: 9 C: 9 </pre> | <ul style="list-style-type: none"> The Code input screen is displayed and the cursor flashes. A flashing cursor indicates that it is waiting for user input. Press the [Up] key to increase the number to 16, and then press the [PROG/ENT] key to jump to code DRV-16. |
| <pre> PAR DRV N STP 0.0Hz 01 Jump Code CODE 1~99 CODE D: 9 C: 9 </pre> | <ul style="list-style-type: none"> DRV-16 (Fwd boost) is displayed. Press the [MODE] key to view the options available and use the [Up] or [Down] key to move to a desired option. |
| <pre> PAR DRV N STP 0.0Hz 16 Fwd Boost 2.0 % 17 Rev Boost 2.0 % 18 Base Freq 60.00 Hz </pre> | <ul style="list-style-type: none"> Press the [PROG/ENT] key to save the selection. The setting is saved and the code is displayed again. |
| <pre> PAR DRV N STP 0.0Hz 00 Jump Code 9 CODE 01 Cmd Frequency 0.00 Hz 02 Keypad Run Dir Forward </pre> | <ul style="list-style-type: none"> Press the ESC key to go back to the initial code of the Drive group (DRV-00). |

3.2.7 Parameter Settings available in Monitor Mode

The H100 inverter allows basic parameters, such as the frequency reference, to be modified in Monitor mode. When the inverter is in Hand or OFF mode, the frequency reference can be entered directly from the monitor screen. When the inverter is in AUTO mode, press the [PROG/ENT] key to access the input screen for a frequency reference.

Parameter setting in HAND/OFF mode

| | |
|--|---|
| <p>MON ← T / K N STP 0.0Hz Frequency 0.00 Hz 0.0 A 0 V</p> | <ul style="list-style-type: none"> • Ensure that the cursor is at the frequency reference item. If not, move the cursor to the frequency reference item. • When the cursor is at the frequency reference item, detailed information is displayed and the cursor flashes at the input line. A flashing cursor indicates that it is waiting for user input. |
| <p>MON ← T / K N STP 0.0Hz Frequency 0.00 Hz 0.0 A 0 V</p> | <ul style="list-style-type: none"> • Press the [Left] or [Right] key to change places. |
| <p>MON ← T / K N STP 0.0Hz Frequency 10.00 Hz 0.0 A 0 V</p> | <ul style="list-style-type: none"> • Press the [Up] or [Down] keys to increase or decrease the numbers, and then press the [Prog/ENT] key to save the change. |

Parameter setting in AUTO mode

| | |
|--|---|
| | <ul style="list-style-type: none"> • Ensure that the cursor is at the frequency reference item. If not, move the cursor to the frequency reference item. • While the cursor is at the frequency reference monitor item, press the [PROG/ENT] key to edit the frequency reference. |
| | <ul style="list-style-type: none"> • Detailed information is displayed and the cursor flashes at the input line. A flashing cursor indicates that it is waiting for user input. |
| | <ul style="list-style-type: none"> • Press the [Left] or [Right] key to move the cursor. |
| | <ul style="list-style-type: none"> • Press the [Up] or [Down] key to increase or decrease the numbers. • When you are done changing the frequency reference, press [PROG/ENT] key to finish setting the parameters. |
| | <ul style="list-style-type: none"> • The newly entered frequency reference is displayed. |

3.2.8 Setting the Monitor Display Items

In Monitor mode, 3 different items may be monitored at once. Certain monitor items, such as the frequency reference, are selectable. The display items to be displayed on the screen can be selected by the user in the Config (CNF) mode. However, in HAND mode or in OFF mode, the first display item is permanently fixed as the frequency reference. On the top-right corner of the keypad display's status bar, another frequency item is displayed. This item refers to the frequency reference when the inverter is not operating and the output frequency when the inverter is operating.

The following example shows how to configure the display items in HAND mode.

| | |
|--|--|
| <pre> MON ← / K [N] STP 0.0Hz Frequency 0.00 Hz 0.0 A 0 V </pre> | <ul style="list-style-type: none"> • Monitor mode is displayed on the keypad. The output frequency, output current, and output voltage are displayed (factory default). |
| <pre> CNF ← [N] STP 0.0Hz 21 Monitor Line-1 Frequency 22 Monitor Line-2 Output Current 23 Monitor Line-3 Output Voltage </pre> | <ul style="list-style-type: none"> • Go to the Config (CNF) mode. In the Config mode, codes CNF-21–23 are used to select the three monitoring display items. The currently selected display item and its setting are highlighted. |
| <pre> CNF ← [N] STP 0.0Hz 21 Monitor Line-1 Frequency 22 Monitor Line-2 Output Current 23 Monitor Line-3 Output Voltage </pre> | <ul style="list-style-type: none"> • To view the available display items and change the setting for the third monitoring display item, press the [Down] key to move to CNF-23 and press the [PROG/ENT] key. • The currently selected display item for CNF-23 (Monitor Line-3) is 'Output Voltage.' |
| <pre> CNF ← [N] STP 0.0Hz 23 Monitor Line-3 2 Output Current DC 3 Output Voltage 4 Output Power </pre> | <ul style="list-style-type: none"> • Press the [Up] or [Down] key to view the available display items. • Move to '4 Output Power' and press the [PROG/ENT] key to change the setting. |



- Press the [MODE] key to go back to Monitor mode. The third display item has been changed to the inverter output power (kW).

3.2.9 Selecting the Status Bar Display Items

On the top-right corner of the display, there is a monitoring display item. This monitoring item is displayed as long as the inverter is turned on, regardless of the mode the inverter is operating in. Configure this monitoring item to display the type of information that suits your needs.

This item can be configured only when the inverter is operating in AUTO mode. In HAND or OFF mode, this monitoring item displays frequency reference only.

The following example shows how to configure this monitoring item in AUTO mode.

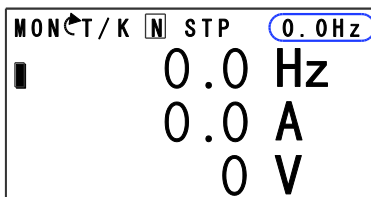

- Monitor mode is displayed.
- On the top-right edge of the display, the frequency reference is displayed (factory default).

Perform Basic Operations

| | |
|---|---|
| <pre> CNF ← [N] STP 0.0Hz 20 Anytime Para Frequency 21 Monitor Line-1 Frequency 22 Monitor Line-2 Output Current </pre> | <ul style="list-style-type: none"> Enter Config mode and go to CNF-20 to select the items to display. |
| <pre> CNF ← [N] STP 0.0Hz 20 AnyTime Para 0 Frequency DC 1 Speed 2 Output Current </pre> | <ul style="list-style-type: none"> Press the [PROG/ENT] key. The currently selected item is highlighted. |
| <pre> CNF ← [N] STP 0.0Hz 20 AnyTime Para 0 Frequency DC 1 Speed 2 Output Current </pre> | <ul style="list-style-type: none"> Press the [Down] key twice to move to '2 (Output Current)', and then press the [PROG/ENT] key to select it. |
| <pre> CNF ← [N] STP 0.0A 20 Anytime Para Output Current 21 Monitor Line-1 Frequency 22 Monitor Line-2 Output Current </pre> | <ul style="list-style-type: none"> The currently selected item is highlighted at CNF- 20 (the display item is changed from 'Frequency' to 'Output Current'). |
| <pre> MON ← T/K [N] STP 0.0A 0.0 Hz 0.0 A 0 V </pre> | <ul style="list-style-type: none"> Press the [MODE] key to return to Monitor mode. |

3.3 Fault Monitoring

3.3.1 Monitoring Faults during Inverter Operation

The following example shows how to monitor faults that occurred during inverter operation.

| | |
|--|---|
| <pre>TRP Current Over Voltage (01) 01 Output Freq 35.10 Hz 02 Output Current 15.5 A</pre> | <ul style="list-style-type: none"> If a fault trip occurs during inverter operation, the inverter enters Trip mode automatically and displays the type of fault trip that occurred. |
| <pre>TRP Current 01 Output Freq 35.10 Hz 02 Output Current 15.5 A 03 Inverter State Steady</pre> | <ul style="list-style-type: none"> Press the [Down] key to view the information on the inverter at the time of fault, including the output frequency, output current, and operation type. |
| <pre>TRP Last-1 00 Trip name(1) External Trip 01 Output Freq 45.10 Hz 02 Output Current 12.0 A</pre> | <ul style="list-style-type: none"> If there were any fault trips that occurred previously, press the [Right] key to display the fault trip information at the times of previous fault trips. |
| <pre>MONCT/K [N] STP 0.0Hz Frequency 0.00 Hz 0.0 A 0 V</pre> | <ul style="list-style-type: none"> When the inverter is reset and the fault trip is released, the keypad display returns to the screen it was at when the fault trip occurred. |

3.3.2 Monitoring Multiple Fault Trips

The following example shows how to monitor multiple faults that occur at the same time.

| | |
|---|--|
| <p>TRP Current Over Voltage (02) 01 Output Freq 35.10 Hz 02 Output Current 15.5 A</p> | <ul style="list-style-type: none"> • If multiple fault trips occur at the same time, the number of fault trips occurred is displayed on the right side of the fault trip type. • Press the [PROG/ENT] key to view the list of all the fault trips. |
| <p>TRP Current 00 Trip Name (02) 01 Over Voltage 02 External Trip</p> | <ul style="list-style-type: none"> • The list of all the fault trips is displayed. • Press the [Down] key to view the types of fault trips that occurred. • Press the [Right] key to display the fault trip information. |
| <p>MON/T/K [N] STP 0.0Hz Frequency 0.00 Hz 0.0 A 0 V</p> | <ul style="list-style-type: none"> • When the inverter is reset and the fault trip is released, the keypad display returns to the screen it was at when the fault trip occurred. |

3.4 Parameter Initialization

The following example demonstrates how to revert all the parameter settings back to the factory default (Parameter Initialization). Parameter initialization may be performed for separate groups in Parameter mode as well.

```

MON←/K [N] STP 0.0Hz
Frequency 0.00 Hz
0.0 A
0 V
    
```

- Monitor mode is displayed.

```

CNF← [N] STP 0.0Hz
00 Jump Code 20 CODE
01 Language Sel English
02 LCD Contrast
□□□□□□□□□□□□□□□□
    
```

- Press the [MODE] key to move to the Config (CNF) mode.

```

CNF← [N] STP 0.0Hz
40 Parameter Init
----- No -----
41 Changed Para View All
42 Multi-Key Sel None
    
```

- Press the [Down] key to go to CNF-40 (Parameter Init).
- Press the [PROG/ENT] key to configure the parameter initialization options.

```

CNF← [N] STP 0.0Hz
40 Parameter Init
0 ----- No ----- DC
1 All Grp
2 DRV Grp
    
```

- In the list of options, select '1(All Grp),' and then press the [PROG/ENT] key to perform parameter initialization.

```

CNF← [N] STP 0.0Hz
40 Parameter Init
----- No -----
41 Changed Para View All
42 Multi-Key Sel None
    
```

- The parameter initialization option is displayed again when the initialization is complete.

4 Learning Basic Features

This chapter describes the basic features of the H100 inverter. Check the reference page in the table to see the detailed description for each of the advanced features.

| Basic Tasks | Description | Ref. |
|---|---|--|
| Operation mode selection (HAND / AUTO / OFF) | Used to select the operation mode. | p.81 |
| Frequency reference source configuration for the keypad | Configures the inverter to allow you to setup or modify a frequency reference using the Keypad. | p.86 |
| Frequency reference source configuration for the terminal block (input voltage) | Configures the inverter to allow input voltages at the terminal block (V1, V2) and to setup or modify a frequency reference. | p.87 p.96 |
| Frequency reference source configuration for the terminal block (input current) | Configures the inverter to allow input currents at the terminal block (I2) and to setup or modify a frequency reference. | p.93 |
| Frequency reference source configuration for the terminal block (input pulse) | Configures the inverter to allow input pulse at the terminal block (TI) and to setup or modify a frequency reference. | p.97 |
| Frequency reference source configuration for RS-485 communication | Configures the inverter to allow communication signals from upper level controllers, such as PLCs or PCs, and to setup or modify a frequency reference. | p.99 |
| Frequency control using analog inputs | Enables the user to hold a frequency using analog inputs at terminals. | p.99 |
| Motor operation display options | Configures the display of motor operation values. Motor operation is displayed either in frequency (Hz) or speed (rpm). | p.99 |
| Multi-step speed (frequency) configuration | Configures multi-step frequency operations by receiving an input at the terminals defined for each step frequency. | p.101 |
| Command source configuration for keypad buttons | Command source configuration for keypad buttons. | p.103 |
| Command source configuration for terminal | Configures the inverter to accept inputs at the FX/RX terminals. | p.104 |

| Basic Tasks | Description | Ref. |
|--|--|-----------------------|
| block inputs | | |
| Command source configuration for RS-485 communication | Configures the inverter to accept communication signals from upper level controllers, such as PLCs or PCs. | p.106 |
| Motor rotation control | Configures the inverter to limit a motor's rotation direction. | p.106 |
| Automatic start-up at power-on | Configures the inverter to start operating at power-on. With this configuration, the inverter begins to run and the motor accelerates as soon as power is supplied to the inverter. To use automatic start-up configuration, the operation command terminals at the terminal block must be turned on. | p.108 |
| Automatic restart after reset of a fault trip condition | Configures the inverter to start operating when the inverter is reset following a fault trip. In this configuration, the inverter starts to run and the motor accelerates as soon as the inverter is reset following a fault trip condition. For automatic start-up configuration to work, the operation command terminals at the terminal block must be turned on. | p.110 |
| Acc/Dec time configuration based on the Max. Frequency | Configures the acceleration and deceleration times for a motor based on a defined maximum frequency. | p.111 |
| Acc/Dec time configuration based on the frequency reference | Configures acceleration and deceleration times for a motor based on a defined frequency reference. | p.113 |
| Multi-stage Acc/Dec time configuration using the multi-function terminal | Configures multi-stage acceleration and deceleration times for a motor based on defined parameters for the multi-function terminals. | p.113 |
| Acc/Dec time transition speed (frequency) configuration | Enables modification of acceleration and deceleration gradients without configuring the multi-functional terminals. | p.115 |
| Acc/Dec pattern configuration | Enables modification of the acceleration and deceleration gradient patterns. Basic patterns to choose from include linear and S-curve patterns. | p.117 |
| Acc/Dec stop command | Stops the current acceleration or deceleration and controls motor operation at a constant speed. Multi-function terminals must be configured for this command. | p.119 |
| Linear V/F pattern | Configures the inverter to run a motor at a constant | p.121 |

| Basic Tasks | Description | Ref. |
|--|---|------------------------------|
| operation | torque. To maintain the required torque, the operating frequency may vary during operation. | |
| Square reduction V/F pattern operation | Configures the inverter to run the motor at a square reduction V/F pattern. Fans and pumps are appropriate loads for square reduction V/F operation. | <u>p.122</u> |
| User V/F pattern configuration | Enables the user to configure a V/F pattern to match the characteristics of a motor. This configuration is for special-purpose motor applications to achieve optimal performance. | <u>p.123</u> |
| Manual torque boost | Manual configuration of the inverter to produce a momentary torque boost. This configuration is for loads that require a large amount of starting torque, such as elevators or lifts. | <u>p.125</u> |
| Automatic torque boost | Automatic configuration of the inverter that provides "auto tuning" that produces a momentary torque boost. This configuration is for loads that require a large amount of starting torque, such as elevators or lifts. | <u>p.126</u> |
| Output voltage adjustment | Adjusts the output voltage to the motor when the power supply to the inverter differs from the motor's rated input voltage. | <u>p.127</u> |
| Accelerating start | Accelerating start is the general way to start motor operation. The typical application configures the motor to accelerate to a target frequency in response to a run command, however there may be other start or acceleration conditions defined. | <u>p.128</u> |
| Start after DC braking | Configures the inverter to perform DC braking before the motor starts rotating again. This configuration is used when the motor will be rotating before the voltage is supplied from the inverter. | <u>p.128</u> |
| Deceleration stop | Deceleration stop is the typical method used to stop a motor. The motor decelerates to 0 Hz and stops on a stop command, however there may be other stop or deceleration conditions defined. | <u>p.129</u> |
| Stopping by DC braking | Configures the inverter to apply DC braking during motor deceleration. The frequency at which DC braking occurs must be defined and during deceleration, when the motor reaches the defined frequency, DC braking is applied. | <u>p.130</u> |
| Free-run stop | Configures the inverter to stop output to the motor | <u>p.131</u> |

| Basic Tasks | Description | Ref. |
|---|---|-----------------------|
| | using a stop command. The motor will free-run until it slows down and stops. | |
| Power braking | Configures the inverter to provide optimal, motor deceleration, without tripping over-voltage protection. | p.132 |
| Start/maximum frequency configuration | Configures the frequency reference limits by defining a start frequency and a maximum frequency. | p.133 |
| Upper/lower frequency limit configuration | Configures the frequency reference limits by defining an upper limit and a lower limit. | p.133 |
| Frequency jump | Configures the inverter to avoid running a motor in mechanically resonating frequencies. | p.136 |
| 2 nd Operation Configuration | Used to configure the 2 nd operation mode and switch between operation modes according to your requirements. | p.137 |
| Multi-function input terminal control configuration | Enables the user to improve the responsiveness of the multi-function input terminals. | p.138 |

4.1 Switching between the Operation Modes (HAND / AUTO / OFF)

The H100 series inverters have two operation modes—the HAND and AUTO modes. HAND mode is used for local control using the keypad. AUTO mode is used for remote control using the terminal inputs or networks commands (the keypad may still be used in AUTO mode if the command source is set as ‘keypad’).

HAND Mode Operation

Follow the instructions listed below to operate the inverter in HAND mode.



- 1 On the keypad, use the [Up], [Down], [Left], or [Right] keys to set the frequency reference.
- 2 Press the [HAND] key. The HAND LED turns on and the inverter starts operating in HAND mode.
- 3 Press the [OFF] key. The OFF LED turns on and the inverter stops operating.

AUTO Mode Operation

Follow the instructions listed below to operate the inverter in AUTO mode.

- 1 Press the [AUTO] key to switch to AUTO mode.
- 2 Operate the inverter using the terminal block input, commands via communication, or keypad input.
- 3 Press the [OFF] key. The OFF LED turns on and the inverter stops operating.

Mode Keys and LED Status

| Keys / LED | Description |
|---|---|
|  | Used to enter the HAND operation mode. |
|  | Used to enter the OFF mode (standby mode) or to reset fault trips. |
|  | Used to enter the AUTO operation mode or to start or stop inverter operation in AUTO mode. |
| HAND LED | Turns on green (steady) during HAND mode operation. |
| OFF LED | Turns on red (steady) while the inverter is in OFF mode (standby), and flashes then a fault trip occurs. The LED turns on red (steady) again when the fault trip condition is released. |
| AUTO LED | Turns on green (steady) when the inverter operates in Auto mode, and flashes green when the inverter is in AUTO mode, but is not operating. |

Basic HAND/AUTO/OFF Mode Operations

| Mode | Description |
|---|---|
| HAND Mode (Locally controlled operation mode) | <p>In HAND mode, operation is available only by the keypad input. In Monitor mode, the currently set frequency reference is displayed at all times. Also, in HAND mode:</p> <ul style="list-style-type: none"> • The first monitoring item is used to adjust the frequency with the up/down and left/right keys. The set frequency is reflected in DRV-02 (HAND Cmd Freq). • The motor's rotation direction can be set at DRV-02 (Keypad Run Dir). • Terminal block functions do not operate (with the exception of BX, External Trip, and multi-step acc/dec operation related terminal functions). • Fire mode commands take the highest priority (if any are given). • The following advanced features are not available: <ul style="list-style-type: none"> - PID / EPID control - Flow compensation - Pump clean - Load tuning - Motor preheating - Time scheduling - PowerOn resume - Multiple motor control • Inverter monitoring and protection features are available in HAND mode. |
| OFF Mode (Standby) | <p>In OFF mode, the inverter operation stops. Pressing the OFF key during HAND/AUTO mode operations will cause the OFF LED to turn on. Then, the inverter stops operating or decelerates and stops, according to the deceleration options set by the user. Also, in AUTO mode:</p> <ul style="list-style-type: none"> • Terminal block functions do not operate (with the exception of BX, External Trip and multi-step acc/dec operation related terminal functions). • Fire mode commands take the highest priority (if any are given). |
| AUTO Mode (Remotely controlled operation mode) | <p>In AUTO mode, the inverter operates based on the command from the command source set at DRV-06 (Cmd Source), with the frequency reference from the source set at DRV-07 (Freq Ref Src).</p> |

Function Codes related to HAND/AUTO/OFF Operation Modes

| Codes / Functions | Description | | | | | | | | |
|--------------------------|---|----------|-------------|---|---|---|--|---|---|
| DRV-01 Cmd Frequency | Frequency reference in AUTO mode when DRV-07 is set to 'KeyPad'. | | | | | | | | |
| DRV-02 KeyPad Run Dir | Rotation direction of the keypad command in the HAND or AUTO mode. <table border="1" style="width: 100%; border-collapse: collapse;"> <thead> <tr> <th>Settings</th> <th>Description</th> </tr> </thead> <tbody> <tr> <td>0</td> <td>Forward Fx operation</td> </tr> <tr> <td>1</td> <td>Reverse Rx operation</td> </tr> </tbody> </table> | Settings | Description | 0 | Forward Fx operation | 1 | Reverse Rx operation | | |
| Settings | Description | | | | | | | | |
| 0 | Forward Fx operation | | | | | | | | |
| 1 | Reverse Rx operation | | | | | | | | |
| DRV-05 KPD H.O.A Lock | To make HAND-OFF-AUTO enabled/disabled <table border="1" style="width: 100%; border-collapse: collapse;"> <thead> <tr> <th>Settings</th> <th>Description</th> </tr> </thead> <tbody> <tr> <td>0</td> <td>Locked To make HAND-OFF-AUTO disabled and turn Auto mode</td> </tr> <tr> <td>1</td> <td>During Run If [DRV-06 Cmd Source] is Fx/Rx-1, Fx/Rx-2, Int485 or fieldbus, HAND-OFF-AUTO is enabled only during working</td> </tr> <tr> <td>3</td> <td>Unlocked To make HAND-OFF-AUTO enabled</td> </tr> </tbody> </table> | Settings | Description | 0 | Locked To make HAND-OFF-AUTO disabled and turn Auto mode | 1 | During Run If [DRV-06 Cmd Source] is Fx/Rx-1, Fx/Rx-2, Int485 or fieldbus, HAND-OFF-AUTO is enabled only during working | 3 | Unlocked To make HAND-OFF-AUTO enabled |
| Settings | Description | | | | | | | | |
| 0 | Locked To make HAND-OFF-AUTO disabled and turn Auto mode | | | | | | | | |
| 1 | During Run If [DRV-06 Cmd Source] is Fx/Rx-1, Fx/Rx-2, Int485 or fieldbus, HAND-OFF-AUTO is enabled only during working | | | | | | | | |
| 3 | Unlocked To make HAND-OFF-AUTO enabled | | | | | | | | |
| DRV-25 HAND Cmd Freq | Frequency displayed at the monitor display item (Monitor Line-1) when the HAND key is pressed in other modes (default frequency reference for HAND mode). | | | | | | | | |
| OUT-31–36 Relay 1–5 | Set AUTO State (36) to ensure that the inverter is in AUTO mode. | | | | | | | | |
| OUT-31–36 Relay 1–5 | Set HAND State (37) to ensure that the inverter is in HAND mode. | | | | | | | | |

Switching between the HAND/AUTO/OFF Modes

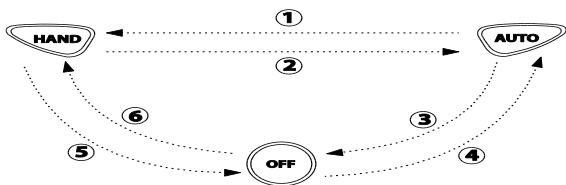

| Mode | Description | | | | | | |
|------------|--|----------|-------------|---|--|---|--|
| ①AUTO→HAND | Press the HAND key in AUTO mode to switch to HAND mode. The inverter operates as follows based on the setting at DRV-26 (Hand Ref Mode). <table border="1" style="width: 100%; border-collapse: collapse;"> <thead> <tr> <th>Settings</th> <th>Description</th> </tr> </thead> <tbody> <tr> <td>0</td> <td>Hand Parameter The inverter operates based on the operation direction set at DRV-02 (Keypad Run Dir) and the frequency reference set at DRV-25 (HAND Cmd Freq).</td> </tr> <tr> <td>1</td> <td>Follow Auto The inverter takes over the operation direction and the frequency reference from the settings for AUTO mode</td> </tr> </tbody> </table> | Settings | Description | 0 | Hand Parameter The inverter operates based on the operation direction set at DRV-02 (Keypad Run Dir) and the frequency reference set at DRV-25 (HAND Cmd Freq). | 1 | Follow Auto The inverter takes over the operation direction and the frequency reference from the settings for AUTO mode |
| Settings | Description | | | | | | |
| 0 | Hand Parameter The inverter operates based on the operation direction set at DRV-02 (Keypad Run Dir) and the frequency reference set at DRV-25 (HAND Cmd Freq). | | | | | | |
| 1 | Follow Auto The inverter takes over the operation direction and the frequency reference from the settings for AUTO mode | | | | | | |

| Mode | Description |
|-----------------|---|
| | and keeps performing the same operation. If the inverter was stopped in AUTO mode, the operation direction is set as Fx and the frequency reference is set as 0 (no inverter output). |
| ②HAND→AUTO O | Press the AUTO key in HAND mode to switch to AUTO mode. The inverter operates based on the command source and frequency reference settings set at DRV-06 and DRV-07. If DRV-06 (Cmd Source) is set to 'keypad' press the AUTO key once again to start inverter operation. |
| ③AUTO→OFF | Press the OFF key in AUTO mode to stop the inverter operation (the inverter enters OFF mode). |
| ④OFF→AUTO | Press the AUTO key in OFF mode to switch to AUTO mode. The inverter operates based on the command source and frequency reference settings set at DRV-06 and DRV-07. If DRV-06 (Cmd Source) is set to 'keypad' press the AUTO key once again to start inverter operation. |
| ⑤HAND→OFF | Press the OFF key in HAND mode to stop the inverter operation (the inverter enters OFF mode). |
| ⑥OFF→HAND | Press the HAND key in OFF mode to switch to HAND mode. The inverter operates based on the operation direction set at DRV-02 (Keypad Run Dir) and the frequency reference set at DRV-25 (HAND Cmd Freq). |

Operation Mode at Power Recovery

If a power interruption occurs during inverter operation in the OFF or HAND mode, the inverter halts the operation with low voltage fault trip. Then, when the power is recovered, the inverter turns on in OFF mode.

If the inverter was operating in AUTO mode at the time of the low voltage trip following the power interruption, the inverter turns on in AUTO mode, and the operation may vary depending on the inverter's 'PowerOn Resume' and 'Power-on run' settings.

Note

- To operate the inverter using the keypad in AUTO mode, set DRV-06 (CMD Source) to 'KeyPad' and press the AUTO key to enter AUTO mode. Then, press the AUTO key on the keypad once again to start the inverter operation.
- If a fault trip occurs during an operation in the AUTO or HAND mode, the inverter can be reset by pressing the OFF key. After the reset, the fault trip is released and the inverter enters OFF mode.
- If a fault trip occurs during an operation in the AUTO or HAND mode, the inverter can be reset using the reset signal from the multi-function input terminal as well. In this case, the inverter turns back on in AUTO mode after the fault trip is released.

⚠ Caution

Use caution when the inverter is set to operate in AUTO mode by commands over communication, and if COM-96 (PowerOn Resume) is set to 'yes', as the motor will begin rotating when the inverter starts up, without additional run commands.

4.2 Setting Frequency Reference

The H100 inverter provides several methods to setup and modify a frequency reference for an operation. The keypad, analog inputs [for example voltage (V1, V2) and current (I2) signals], or RS-485 (digital signals from higher-level controllers, such as PC or PLC) can be used.

| Group | Code | Name | LCD Display | Parameter Setting | | Setting Range | Unit |
|-------|------|----------------------------|--------------|-------------------|-----------|---------------|------|
| DRV | 7 | Frequency reference source | Freq Ref Src | 0 | KeyPad-1 | 0-11 | - |
| | | | | 1 | KeyPad-2 | | |
| | | | | 2 | V1 | | |
| | | | | 4 | V2 | | |
| | | | | 5 | I2 | | |
| | | | | 6 | Int 485 | | |
| | | | | 7 | Field Bus | | |
| | | | | 9 | Pulse | | |
| | | | | 10* | V3 | | |
| | | | | 11 | I3 | | |

* '10(V3)~11(I3)' of DRV-07 are available when Extension IO option is equipped. Refer to Extension IO option manual for more detailed information.

4.2.1 Keypad as the Source (Keypad-1 setting)

You can modify frequency reference by using the keypad and apply changes by pressing the [ENT/PROG] key. To use the keypad as a frequency reference input source, go to DRV-07 (Frequency reference source) and change the parameter value to '0 (Keypad-1)'. Input the frequency reference for an operation at DRV-01 (Frequency reference).

| Group | Code | Name | LCD Display | Parameter Setting | | Setting Range | Unit |
|-------|------|----------------------------|---------------|-------------------|----------|----------------------------|------|
| DRV | 01 | Frequency reference | Cmd Frequency | 0.00 | | 0.00, Low Freq– High Freq* | Hz |
| | 07 | Frequency reference source | Freq Ref Src | 0 | Keypad-1 | 0–11 | - |

* You cannot set a frequency reference that exceeds the Max. Frequency, as configured with DRV-20.

4.2.2 Keypad as the Source (Keypad-2 setting)

You can use the [UP] and [DOWN] cursor keys to modify a frequency reference. To use this as a second option, set the keypad as the source of the frequency reference, by going to DRV-07 (Frequency reference source) and change the parameter value to '1 (Keypad-2)'. This allows frequency reference values to be increased or decreased by pressing the [UP] and [DOWN] cursor keys.

| Group | Code | Name | LCD Display | Parameter Setting | | Setting Range | Unit |
|-------|------|----------------------------|--------------|-------------------|----------|----------------------------|------|
| DRV | 07 | Frequency reference source | Freq Ref Src | 1 | Keypad-2 | 0–11 | - |
| | 01 | Frequency reference | | 0.00 | | 0.00, Low Freq– High Freq* | Hz |

*You cannot set a frequency reference that exceeds the Max. Frequency, as configured with DRV-20.

4.2.3 V1 Terminal as the Source

You can set and modify a frequency reference by setting voltage inputs when using the V1 terminal. Use voltage inputs ranging from 0–10 V (unipolar) for forward only operation. Use voltage inputs ranging from -10 to +10 V (bipolar) for both directions, where negative voltage inputs are used in reverse operations.

4.2.3.1 Setting a Frequency Reference for 0–10 V Input

Set IN-06 (V1 Polarity) to '0 (unipolar)'. Use a voltage output from an external source or use the voltage output from the VR terminal to provide inputs to V1. Refer to the diagrams below for the wiring required for each application.

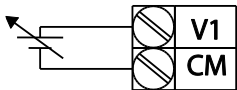

[External source application]

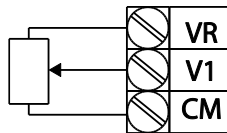

[Internal source (VR) application]

| Group | Code | Name | LCD Display | Parameter Setting | | Setting Range | Unit |
|-------|------|-----------------------------------|---------------|-------------------|----------|---------------------|------|
| DRV | 07 | Frequency reference source | Freq Ref Src | 2 | V1 | 0–11 | - |
| IN | 01 | Frequency at maximum analog input | Freq at 100% | Maximum frequency | | 0.00–Max. Frequency | Hz |
| | 05 | V1 input monitor | V1 Monitor[V] | 0.00 | | 0.00–12.00 | V |
| | 06 | V1 polarity options | V1 Polarity | 0 | Unipolar | 0–1 | - |
| | 07 | V1 input filter time constant | V1 Filter | 10 | | 0–10000 | msec |
| | 08 | V1 minimum input voltage | V1 volt x1 | 0.00 | | 0.00–10.00 | V |
| | 09 | V1 output at minimum voltage (%) | V1 Perc y1 | 0.00 | | 0.00–100.00 | % |
| | 10 | V1 maximum input voltage | V1 Volt x2 | 10.00 | | 0.00–12.00 | V |
| | 11 | V1 output at maximum voltage (%) | V1 Perc y2 | 100.00 | | 0–100 | % |

| Group | Code | Name | LCD Display | Parameter Setting | | Setting Range | Unit |
|-------|------|----------------------------|---------------|-------------------|----|-------------------|------|
| | 16 | Rotation direction options | V1 Inverting | 0 | No | 0–1 | - |
| | 17 | V1 Quantizing level | V1 Quantizing | 0.04 | | 0.00*, 0.04–10.00 | % |

* Quantizing is disabled if '0' is selected.

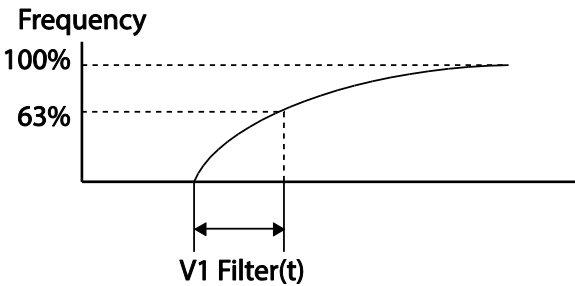
| Code | Description |
|---------------------|--|
| IN-01 Freq at 100% | <p>Configures the frequency reference at the maximum input voltage when a potentiometer is connected to the control terminal block. A frequency set with code IN-01 becomes the maximum frequency only if the value set in code IN-11 (or IN-15) is 100 (%).</p> <ul style="list-style-type: none"> Set code IN-01 to 40.00 and use default values for codes IN-02–IN-16. Motor will run at 40.00 Hz when a 10 V input is provided at V1. Set code IN-11 to 50.00 and use default values for codes IN-01–IN-16. Motor will run at 30.00 Hz (50% of the default maximum frequency–60 Hz) when a 10 V input is provided at V1. |
| IN-05 V1 Monitor[V] | Configures the inverter to monitor the input voltage at V1. |
| IN-07 V1 Filter | <p>V1 Filter may be used when there are large variations between reference frequencies. Variations can be mitigated by increasing the time constant, but this requires an increased response time.</p> <p>The value t (time) indicates the time required for the frequency to reach 63% of the reference, when external input voltages are provided in multiple steps.</p> <p>V1 input from external source </p>  <p style="text-align: center;">[V1 Filter]</p> |
| IN-08 V1 volt x1– | These parameters are used to configure the gradient level and offset |

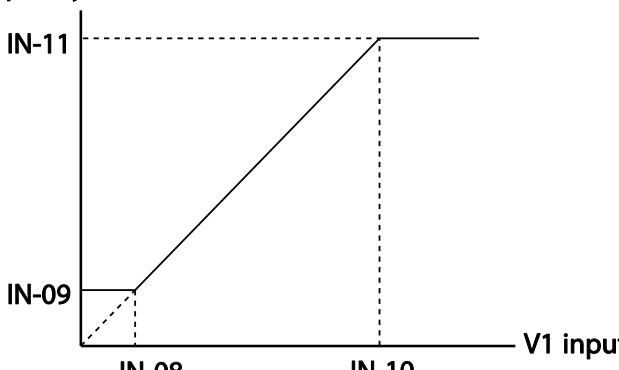
| | |
|----------------------------|--|
| <p>IN-11 V1 Perc y2</p> | <p>values of the Output Frequency, based on the Input Voltage. Frequency reference</p>  |
| <p>IN-16 V1 Inverting</p> | <p>Inverts the direction of rotation. Set this code to '1 (Yes)' if you need the motor to run in the opposite direction from the current rotation.</p> |
| <p>IN-17 V1 Quantizing</p> | <p>Quantizing may be used when the noise level is high in the analog input (V1 terminal) signal. Quantizing is useful when you are operating a noise-sensitive system, because it suppresses any signal noise. However, quantizing will diminish system sensitivity (resultant power of the output frequency will decrease based on the analog input). You can also turn on the low-pass filter using code IN-07 to reduce the noise, but increasing the value will reduce responsiveness and may cause pulsations (ripples) in the output frequency.</p> <p>Parameter values for quantizing refer to a percentage based on the maximum input. Therefore, if the value is set to 1% of the analog maximum input (60 Hz), the output frequency will increase or decrease by 0.6 Hz per 0.1 V difference.</p> <p>When the analog input is increased, an increase to the input equal to 75% of the set value will change the output frequency, and then the frequency will increase according to the set value. Likewise, when the analog input decreases, a decrease in the input equal to 75% of the set value will make an initial change to the output frequency.</p> <p>As a result, the output frequency will be different at acceleration and deceleration, mitigating the effect of analog input changes over the output frequency. (ripple)</p> |

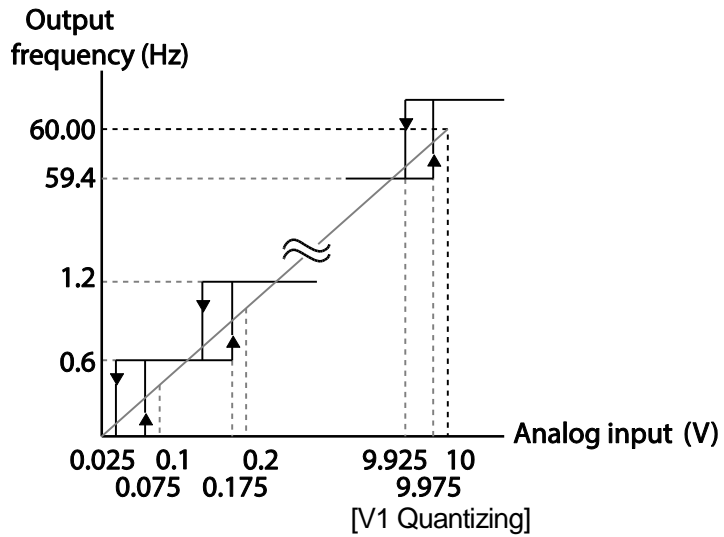

0–10 V Input Voltage Setting Details

4.2.3.2 Setting a Frequency Reference for -10→+10 V Input

Set DRV-07 (Frequency reference source) to '2 (V1)', and then set IN-06 (V1 Polarity) to '1 (bipolar)'. Use the output voltage from an external source to provide input to V1.

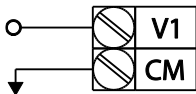

[V1 terminal wiring]

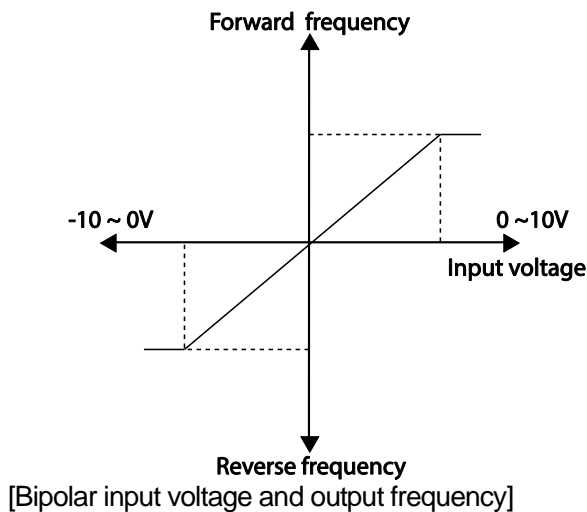

| Group | Code | Name | LCD Display | Parameter Setting | | Setting Range | Unit |
|-------|------|-----------------------------------|--------------|-------------------|---------|------------------|------|
| DRV | 07 | Frequency reference source | Freq Ref Src | 2 | V1 | 0-11 | - |
| IN | 01 | Frequency at maximum analog input | Freq at 100% | 60.00 | | 0- Max Frequency | Hz |
| | 05 | V1 input monitor | V1 Monitor | 0.00 | | -12.00-12.00 V | V |
| | 06 | V1 polarity options | V1 Polarity | 1 | Bipolar | 0-1 | - |
| | 12 | V1 minimum input voltage | V1- volt x1 | 0.00 | | -10.00-0.00 V | V |
| | 13 | V1 output at minimum voltage (%) | V1- Perc y1 | 0.00 | | -100.00-0.00% | % |
| | 14 | V1 maximum input | V1- Volt x2 | -10.00 | | -12.00-0.00 | V |

| Group | Code | Name | LCD Display | Parameter Setting | Setting Range | Unit |
|-------|------|----------------------------------|-------------|-------------------|---------------|------|
| | | voltage | | | V | |
| | 15 | V1 output at maximum voltage (%) | V1- Perc y2 | -100.00 | -100.00–0.00% | % |

Rotational Directions for Different Voltage Inputs

| Command / Voltage Input | Input voltage | |
|-------------------------|---------------|---------|
| | 0–10 V | -10–0 V |
| FWD | Forward | Reverse |
| REV | Reverse | Forward |

-10–10 V Voltage Input Setting Details

| Code | Description |
|---|--|
| IN-12 V1- volt x1– IN-15 V1- Perc y2 | <p>Sets the gradient level and off-set value of the output frequency in relation to the input voltage. These codes are displayed only when IN-06 is set to '1 (bipolar)'.</p> <p>As an example, if the minimum input voltage (at V1) is set to -2 (V) with 10% output ratio, and the maximum voltage is set to -8 (V) with 80% output ratio respectively, the output frequency will vary within the range of 6–48 Hz.</p> <p>For details about the 0–+10 V analog inputs, refer to the code descriptions IN-08 V1 volt x1–IN-11 V1 Perc y2 on page 89.</p> |

4.2.3.3 Setting a Reference Frequency using Input Current (I2)

You can set and modify a frequency reference using input current at the I2 terminal after selecting current input at SW4. Set DRV-07 (Frequency reference source) to '5 (I2)' and apply 0–20 mA input current to I2.

| Group | Code | Name | LCD Display | Parameter Setting | | Setting Range | Unit |
|-------|------|-----------------------------------|---------------|-------------------|----|---------------------|------|
| DRV | 07 | Frequency reference source | Freq Ref Src | 5 | I2 | 0–11 | - |
| IN | 01 | Frequency at maximum analog input | Freq at 100% | 60.00 | | 0–Maximum Frequency | Hz |
| | 50 | I2 input monitor | I2 Monitor | 0.00 | | 0.00–24.00 | mA |
| | 52 | I2 input filter time constant | I2 Filter | 10 | | 0–10000 | ms |
| | 53 | I2 minimum input current | I2 Curr x1 | 4.00 | | 0.00–20.00 | mA |
| | 54 | I2 output at minimum current (%) | I2 Perc y1 | 0.00 | | 0–100 | % |
| | 55 | I2 maximum input current | I2 Curr x2 | 20.00 | | 0.00–24.00 | mA |
| | 56 | I2 output at maximum current (%) | I2 Perc y2 | 100.00 | | 0.00–100.00 | % |
| | 61 | I2 rotation direction options | I2 Inverting | 0 | No | 0–1 | - |
| | 62 | I2 Quantizing level | I2 Quantizing | 0.04 | | 0.00*, 0.04–10.00 | % |

* Quantizing is disabled if '0' is selected.

Input Current (I2) Setting Details

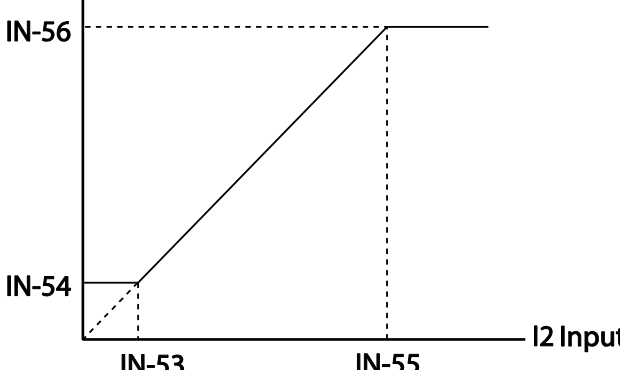
| Code | Description |
|---------------------------------------|---|
| IN-01 Freq at 100% | <p>Configures the frequency reference for operation at the maximum current (when IN-55 is set to 100%).</p> <ul style="list-style-type: none"> • If IN-01 is set to 40.00, and default settings are used for IN-53–56, 20 mA input current (max) to I2 will produce a frequency reference of 40.00 Hz. • If IN-56 is set to 50.00, and default settings are used for IN-01 (60 Hz) and IN-53–55, 20 mA input current (max) to I2 will produce a frequency reference of 30.00 Hz (50% of 60 Hz). |
| IN-50 I2 Monitor | Used to monitor input current at I2. |
| IN-52 I2 Filter | Configures the time for the operation frequency to reach 63% of target frequency based on the input current at I2. |
| IN-53 I2 Curr x1– IN-56 I2 Perc y2 | <p>Configures the gradient level and off-set value of the output frequency.</p> <p>Frequency Reference</p>  <p>[Gradient and off-set configuration based on output frequency]</p> |

4.2.4 Setting a Frequency Reference with Input Voltage (Terminal I2)

Set and modify a frequency reference using input voltage at I2 (V2) terminal by setting SW2 to V2. Set the DRV-07 (Frequency reference source) to 4 (V2) and apply 0–12 V input voltage to I2 (=V2, Analog current/voltage input terminal). Codes IN-35–47 will not be displayed when I2 is set to receive current input (DRV-07 is set to '5').

| Group | Code | Name | LCD Display | Parameter Setting | | Setting Range | Unit |
|-------|---------------------|--------------------------------|--------------|-------------------|-------------------|---------------|------|
| DRV | 07 | Frequency reference source | Freq Ref Src | 4 | V2 | 0–11 | - |
| IN | 35 | V2 input display | V2 Monitor | 0.00 | | 0.00–12.00 | V |
| | 37 | V2 input filter time constant | V2 Filter | 10 | | 0–10000 | msec |
| | 38 | Minimum V2 input voltage | V2 Volt x1 | 0.00 | | 0.00–10.00 | V |
| | 39 | Output% at minimum V2 voltage | V2 Perc y1 | 0.00 | | 0.00–100.00 | % |
| | 40 | Maximum V2 input voltage | V2 Volt x2 | 10.00 | | 0.00–10.00 | V |
| | 41 | Output% at maximum V2 voltage | V2 Perc y2 | 100.00 | | 0.00–100.00 | % |
| | 46 | Invert V2 rotational direction | V2 Inverting | 0 | No | 0–1 | - |
| 47 | V2 quantizing level | V2 Quantizing | 0.04 | | 0.00*, 0.04–10.00 | % | |

* Quantizing is disabled if '0' is selected.

4.2.5 Setting a Frequency with TI Pulse Input

Set a frequency reference by setting the Frq (Frequency reference source) code (code 07) in DRV group to 9 (Pulse) and provide 0–32.00 kHz pulse frequency to TI terminal.

| Group | Code | Name | LCD Display | Parameter Setting | | Setting Range | Unit |
|-------|------|-----------------------------------|---------------|-------------------|-------|------------------------|------|
| DRV | 07 | Frequency reference source | Freq Ref Src | 9 | Pulse | 0–11 | - |
| IN | 01 | Frequency at maximum analog input | Freq at 100% | 60.00 | | 0.00–Maximum frequency | Hz |
| | 91 | Pulse input display | TI Monitor | 0.00 | | 0.00–50.00 | kHz |
| | 92 | TI input filter time constant | TI Filter | 10 | | 0–9999 | msec |
| | 93 | TI input minimum pulse | TI Pls x1 | 0.00 | | 0.00–32.00 | kHz |
| | 94 | Output% at TI minimum pulse | TI Perc y1 | 0.00 | | 0.00–100.00 | % |
| | 95 | TI Input maximum pulse | TI Pls x2 | 32.00 | | 0.00–32.00 | kHz |
| | 96 | Output% at TI maximum pulse | TI Perc y2 | 100.00 | | 0.00–100.00 | % |
| | 97 | Invert TI direction of rotation | TI Inverting | 0 | No | 0–1 | - |
| | 98 | TI quantizing level | TI Quantizing | 0.04 | | 0.00*, 0.04–10.00 | % |

*Quantizing is disabled if '0' is selected.

TI Pulse Input Setting Details

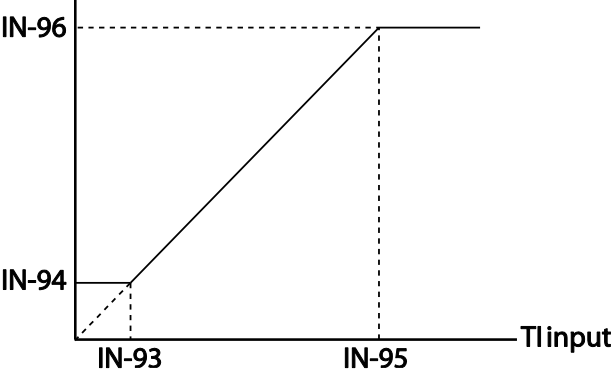
| Code | Description |
|---|--|
| IN-01 Freq at 100% | <p>Configures the frequency reference at the maximum pulse input. The frequency reference is based on 100% of the value set with IN-96.</p> <ul style="list-style-type: none"> • If IN-01 is set to 40.00 and codes IN-93–96 are set at default, 32 kHz input to TI yields a frequency reference of 40.00 Hz. • If IN-96 is set to 50.00 and codes IN-01, IN-93–95 are set at default, 32 kHz input to the TI terminal yields a frequency reference of 30.00 Hz. |
| IN-91 TI Monitor | Displays the pulse frequency supplied at TI. |
| IN-92 TI Filter | Sets the time for the pulse input at TI to reach 63% of its nominal frequency (when the pulse frequency is supplied in multiple steps). |
| IN-93 TI Pls x1– IN-96 TI Perc y2 | <p>Configures the gradient level and offset values for the output frequency.</p> <p>Frequency reference</p>  |
| IN-97 TI Inverting– IN-98 TI Quantizing | Identical to IN-16–17 (refer to IN-16 V1 Inverting/IN-17 V1 Quantizing on page 90) |

4.2.6 Setting a Frequency Reference via RS-485 Communication

Control the inverter with upper-level controllers, such as PCs or PLCs, via RS-485 communication. Set the Frq (Frequency reference source) code (code 07) in the DRV group to 6 (Int 485) and use the RS-485 signal input terminals (S+/S-/SG) for communication. Refer to 7 RS-485 Communication features on page 339.

| Group | Code | Name | LCD Display | Parameter Setting | | Setting Range | Unit |
|-------|------|--|--------------|-------------------|---------------|---------------|------|
| DRV | 07 | Frequency reference source | Freq Ref Src | 6 | Int 485 | 0–11 | - |
| COM | 01 | Integrated RS-485 communication inverter ID | Int485 St ID | - | 1 | 1–MaxComID* | - |
| | 02 | Integrated communication protocol | Int485 Proto | 0 | ModBus RTU | 0–6 | - |
| | | | | 2 | LS Inv 485 | | |
| | | | | 4 | BACnet | | |
| | | | | 5 | Metasys-N2 | | |
| | | | | 6** | Modbus Master | | |
| | 03 | Integrated communication speed | Int485 BaudR | 3 | 9600 bps | 0–8 | - |
| | 04 | Integrated communication frame configuration | Int485 Mode | 0 | D8/PN/S1 | 0–3 | - |
| | | | | 1 | D8/PN/S2 | | |
| | | | | 2 | D8/PE/S1 | | |
| 3 | | | | D8/PO/S1 | | | |

*If AP1-40 is set to '4(Serve Drv)', MaxComID is '8', and if COM-02 is set to '4(BACnet)', MaxComID is '127'. Otherwise MaxComID is '250'.

** COM-02 is automatically set to '6(Modbus Master)' when AP1-40 is set to '2 or 3'. Otherwise a user can set the parameter value at user's choice.

4.3 Frequency Hold by Analog Input

If you set a frequency reference via analog input at the control terminal block, you can hold the operation frequency of the inverter by assigning a multi-function input as the analog frequency hold terminal. The operation frequency will be fixed upon an analog input signal.

| Group | Code | Name | LCD Display | Parameter Setting | | Setting Range | Unit |
|-------|------|----------------------------|--------------|-------------------|----------|---------------|------|
| DRV | 07 | Frequency reference source | Freq Ref Src | 0 | Keypad-1 | 0-11 | - |
| | | | | 1 | Keypad-2 | | |
| | | | | 2 | V1 | | |
| | | | | 4 | V2 | | |
| | | | | 5 | I2 | | |
| | | | | 6 | Int 485 | | |
| | | | | 7 | Fied Bus | | |
| | | | | 9 | Pulse | | |
| | | | | 10* | V3 | | |
| | | | | 11 | I3 | | |
| | | | | IN | 65-71 | | |

*'10(V3)~11(I3)' of DRV-07 are available when Extension IO option is equipped. Refer to Extension IO option manual for more detailed information.

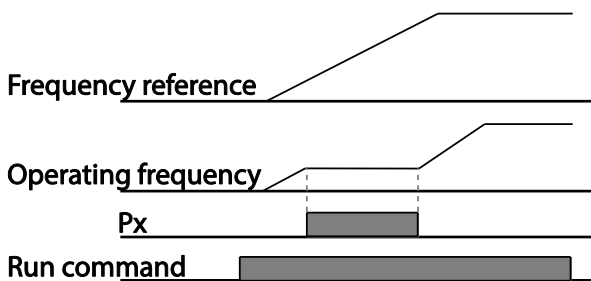

4.4 Changing the Displayed Units (Hz↔Rpm)

You can change the units used to display the operational speed of the inverter by setting DRV- 21 (Speed unit selection) to 0 (Hz Display) or 1 (Rpm Display).

| Group | Code | Name | LCD Display | Parameter Setting | | Setting Range | Unit |
|-------|------|----------------------|-------------|-------------------|-------------|---------------|------|
| DRV | 21 | Speed unit selection | Hz/Rpm Sel | 0 | Hz Display | 0-1 | - |
| | | | | 1 | Rpm Display | | |

4.5 Setting Multi-step Frequency

Multi-step operations can be carried out by assigning different speeds (or frequencies) to the Px terminals. Step 0 uses the frequency reference source set at DRV-07. Px terminal parameter values 7 (Speed-L), 8 (Speed-M) and 9 (Speed-H) are recognized as binary commands and work in combination with Fx or Rx run commands. The inverter operates according to the frequencies set with BAS-50-56 (multi-step frequency 1-7) and the binary command combinations.

| Group | Code | Name | LCD Display | Parameter Setting | | Setting Range | Unit |
|-------|-------|-------------------------------|----------------------|-------------------|---------|----------------------------|------|
| BAS | 50-56 | Multi-step frequency 1-7 | Step Freq - 1-7 | - | | 0.00, Low Freq- High Freq* | Hz |
| IN | 65-71 | Px terminal configuration | Px Define(Px: P1-P7) | 7 | Speed-L | 0-55 | - |
| | | | | 8 | Speed-M | | - |
| | | | | 9 | Speed-H | | - |
| | 89 | Multi-step command delay time | InCheck Time | 1 | | 1-5000 | ms |

Multi-step Frequency Setting Details

| Code | Description | | | | | | | | | | | | | | | | | | | | | | | | | | | | | | | | | | | | | | | | | | | | | |
|--------------------|--|-------|-------|----|----|----|---|---|---|---|---|---|---|---|---|---|---|---|---|---|---|---|---|---|---|---|---|---|---|---|---|---|---|---|---|---|---|---|---|---|---|---|---|---|---|---|
| BAS Group 50–56 | Configure multi-step frequency 1–7. | | | | | | | | | | | | | | | | | | | | | | | | | | | | | | | | | | | | | | | | | | | | | |
| IN-65–71 Px Define | <p>Choose the terminals to setup as multi-step inputs, and then set the relevant codes (IN-65–71) to 7 (Speed-L), 8 (Speed-M), or 9 (Speed-H). Provided that terminals P5, P6, and P7 have been set to Speed-L, Speed-M and Speed-H respectively, the following multi-step operation will be available.</p> <p>[An example of a multi-step operation]</p> <table border="1"> <thead> <tr> <th>Speed</th> <th>Fx/Rx</th> <th>P7</th> <th>P6</th> <th>P5</th> </tr> </thead> <tbody> <tr> <td>0</td> <td>✓</td> <td>-</td> <td>-</td> <td>-</td> </tr> <tr> <td>1</td> <td>✓</td> <td>-</td> <td>-</td> <td>✓</td> </tr> <tr> <td>2</td> <td>✓</td> <td>-</td> <td>✓</td> <td>-</td> </tr> <tr> <td>3</td> <td>✓</td> <td>-</td> <td>✓</td> <td>✓</td> </tr> <tr> <td>4</td> <td>✓</td> <td>✓</td> <td>-</td> <td>-</td> </tr> <tr> <td>5</td> <td>✓</td> <td>✓</td> <td>-</td> <td>✓</td> </tr> <tr> <td>6</td> <td>✓</td> <td>✓</td> <td>✓</td> <td>-</td> </tr> <tr> <td>7</td> <td>✓</td> <td>✓</td> <td>✓</td> <td>✓</td> </tr> </tbody> </table> | Speed | Fx/Rx | P7 | P6 | P5 | 0 | ✓ | - | - | - | 1 | ✓ | - | - | ✓ | 2 | ✓ | - | ✓ | - | 3 | ✓ | - | ✓ | ✓ | 4 | ✓ | ✓ | - | - | 5 | ✓ | ✓ | - | ✓ | 6 | ✓ | ✓ | ✓ | - | 7 | ✓ | ✓ | ✓ | ✓ |
| Speed | Fx/Rx | P7 | P6 | P5 | | | | | | | | | | | | | | | | | | | | | | | | | | | | | | | | | | | | | | | | | | |
| 0 | ✓ | - | - | - | | | | | | | | | | | | | | | | | | | | | | | | | | | | | | | | | | | | | | | | | | |
| 1 | ✓ | - | - | ✓ | | | | | | | | | | | | | | | | | | | | | | | | | | | | | | | | | | | | | | | | | | |
| 2 | ✓ | - | ✓ | - | | | | | | | | | | | | | | | | | | | | | | | | | | | | | | | | | | | | | | | | | | |
| 3 | ✓ | - | ✓ | ✓ | | | | | | | | | | | | | | | | | | | | | | | | | | | | | | | | | | | | | | | | | | |
| 4 | ✓ | ✓ | - | - | | | | | | | | | | | | | | | | | | | | | | | | | | | | | | | | | | | | | | | | | | |
| 5 | ✓ | ✓ | - | ✓ | | | | | | | | | | | | | | | | | | | | | | | | | | | | | | | | | | | | | | | | | | |
| 6 | ✓ | ✓ | ✓ | - | | | | | | | | | | | | | | | | | | | | | | | | | | | | | | | | | | | | | | | | | | |
| 7 | ✓ | ✓ | ✓ | ✓ | | | | | | | | | | | | | | | | | | | | | | | | | | | | | | | | | | | | | | | | | | |
| IN-89 InCheck Time | <p>Set a time interval for the inverter to check for additional terminal block inputs after receiving an input signal. After adjusting IN-89 to 100 ms and an input signal is received at P6, the inverter will search for inputs at other terminals for 100 ms, before proceeding to accelerate or decelerate based on the configuration at P6.</p> | | | | | | | | | | | | | | | | | | | | | | | | | | | | | | | | | | | | | | | | | | | | | |

4.6 Command Source Configuration

Various devices can be selected as command input devices for the H100 inverter. Input devices available to select include keypad, multi-function input terminal, RS-485 communication and field bus adapter.

| Group | Code | Name | LCD Display | Parameter Setting | | Setting Range | Unit |
|-------|------|----------------|-------------|-------------------|------------|---------------|------|
| DRV | 06 | Command Source | Cmd Source | 0 | Keypad | 0-5 | - |
| | | | | 1 | Fx/Rx-1 | | |
| | | | | 2 | Fx/Rx-2 | | |
| | | | | 3 | Int 485 | | |
| | | | | 4 | Field Bus | | |
| | | | | 5 | Time Event | | |

4.6.1 The Keypad as a Command Input Device

To use the keypad as the command source, press the [AUTO] key to enter AUTO mode. Set DRV-06 to '0 (Keypad)' to select the keypad as the command source and set the operation direction at DRV-02 (Keypad Run Dir).

Since the keypad is now the command source, operation starts when the AUTO key is pressed, and it stops when the AUTO key is pressed again.

The OFF key may be used to stop the operation as well, but the inverter operation mode will be changed to OFF mode.

| Group | Code | Name | LCD Display | Parameter Setting | | Setting Range | Unit |
|-------|------|----------------|-------------|-------------------|--------|---------------|------|
| DRV | 06 | Command source | Cmd Source | 0 | KeyPad | 0-5 | - |

4.6.2 Terminal Block as a Command Input Device (Fwd/Rev run commands)

Multi-function terminals can be selected as a command input device. This is configured by setting DRV-06 (command source) in the Drive group to '1 (Fx/Rx)'. Select 2 terminals for the forward and reverse operations, and then set the relevant codes (2 of the 7 multi-function terminal codes, IN-65–71 for P1–P7) to '1 (Fx)' and '2 (Rx)' respectively. This application enables both terminals to be turned on or off at the same time, constituting a stop command that will cause the inverter to stop operation.

| Group | Code | Name | LCD Display | Parameter Setting | | Setting Range | Unit |
|-------|-------|--------------------------------|----------------------|-------------------|---------|---------------|------|
| IN | 02 | Operation direction for Keypad | Keypad Run Dir | 0 | Reverse | 0–1 | - |
| | | | | 1 | Forward | | |
| DRV | 06 | Command source | Cmd Source | 1 | Fx/Rx-1 | 0–5 | - |
| IN | 65–71 | Px terminal configuration | Px Define(Px: P1–P7) | 1 | Fx | 0–55 | - |
| | | | | 2 | Rx | | |

Fwd/Rev Command by Multi-function Terminal – Setting Details

| Code | Description |
|--------------------|--|
| DRV-06Cmd Source | Set to 1 (Fx/Rx-1). |
| IN-65–71 Px Define | Assign a terminal for forward (Fx) operation. Assign a terminal for reverse (Rx) operation. |

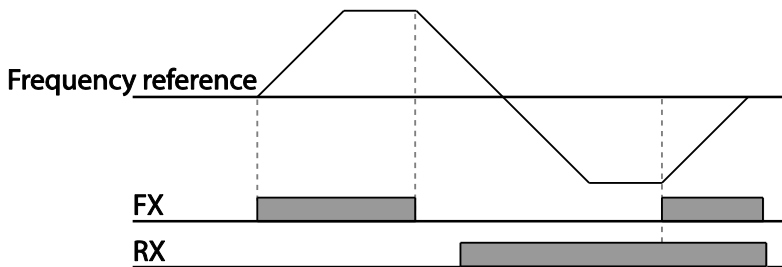

4.6.3 Terminal Block as a Command Input Device (Run and Rotation Direction Commands)

Multi-function terminals can be selected as a command input device. This is configured by setting DRV-06 (command source) in the Drive group to 2(Fx/Rx-2). Select 2 terminals for run and rotation direction commands, and then select the relevant codes (2 of the 5 multi-function terminal codes, IN-65–71 for P1–P7) to 1 (Fx) and 2 (Rx) respectively. This application uses an Fx input as a run command, and an Rx input to change a motor's rotation direction (On: Rx, Off: Fx).

| Group | Code | Name | LCD Display | Parameter Setting | | Setting Range | Unit |
|-------|-------|---------------------------|-------------------------|-------------------|---------|---------------|------|
| DRV | 06 | Command source | Cmd Source | 2 | Fx/Rx-2 | 0-5 | - |
| IN | 65-71 | Px terminal configuration | Px Define (Px: P1 - P7) | 1 | Fx | 0-55 | - |
| | | | | 2 | Rx | | |

Run Command and Fwd/Rev Change Command Using Multi-function Terminal – Setting Details

| Code | Description |
|--------------------|--|
| DRV-06 Cmd Source | Set to '2 (Fx/Rx-2)'. |
| IN-65-71 Px Define | Assign a terminal for run command (Fx). Assign a terminal for changing rotation direction (Rx). |

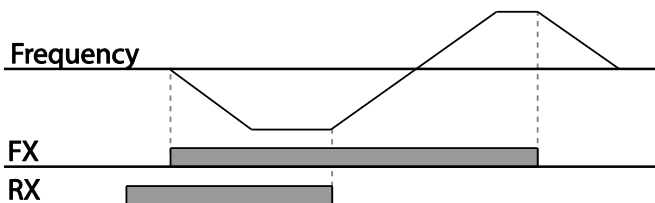

4.6.4 RS-485 Communication as a Command Input Device

Internal RS-485 communication can be selected as a command input device by setting DRV-06 (command source) in the Drive group to '3 (Int 485)'. This configuration uses upper level controllers such as PCs or PLCs to control the inverter by transmitting and receiving signals via the S+, S-, and RS-485 signal input terminals at the terminal block. For more details, refer to 7 RS-485 Communication Features on page 339.

| Group | Code | Name | LCD Display | Parameter Setting | | Setting Range | Unit |
|-------|------|--------------------------------------|--------------|-------------------|--------------|-----------------|------|
| DRV | 06 | Command source | Cmd Source | 3 | Int 485 | 0-5 | - |
| COM | 01 | Integrated communication inverter ID | Int485 St ID | 1 | | 1- MaxComID* | - |
| | 02 | Integrated communication protocol | Int485 Proto | 0 | ModBus RTU | 0-6 | - |
| | 03 | Integrated communication speed | Int485 BaudR | 3 | 9600 bps | 0-8 | - |
| | 04 | Integrated communication frame setup | Int485 Mode | 0 | D8 / PN / S1 | 0-3 | - |

*If AP1-40 is set to '4(Serve Drv)', MaxComID is '8', and if COM-02 is set to '4(BACnet), MaxComID is '127'. Otherwise MaxComID is '250'

4.7 Forward or Reverse Run Prevention

The rotation direction of motors can be configured to prevent motors to only run in one direction. Pressing the [REV] key on the keypad when direction prevention is configured, will cause the motor to decelerate to 0 Hz and stop. The inverter will remain on.

| Group | Code | Name | LCD Display | Parameter Setting | | Setting Range | Unit |
|-------|------|------------------------|-------------|-------------------|--------------|---------------|------|
| ADV | 09 | Run prevention options | Run Prevent | 0 | None | 0–2 | - |
| | | | | 1 | Forward Prev | | |
| | | | | 2 | Reverse Prev | | |

Forward/Reverse Run Prevention Setting Details

| Code | Description | |
|--------------------|--------------------------------|--------------|
| ADV-09 Run Prevent | Choose a direction to prevent. | |
| | Setting | |
| | 0 | None |
| | 1 | Forward Prev |
| | 2 | Reverse Prev |
| | Description | |
| | Do not set run prevention. | |
| | Set forward run prevention. | |
| | Set reverse run prevention. | |

4.8 Power-on Run

A power-on run feature can be setup to start an inverter operation after powering up based on the run commands by terminal inputs or communication (if they are configured). In AUTO mode, the inverter starts operating at power-on when the following conditions are met.

Terminal block input as the command source

(If they have been configured). To enable power-on run, set DRV-06 (command source) to '1 (Fx/Rx-1)' or '2 (Fx/Rx-2)' in the Drive group and ADV-10 to '1' in the Advanced group.

| Group | Code | Name | LCD Display | Parameter Setting | | Setting Range | Unit |
|-------|------|----------------|--------------|-------------------|--------------------|---------------|------|
| DRV | 06 | Command source | Cmd Source | 1, 2 | Fx/Rx-1 or Fx/Rx-2 | 0-5 | - |
| ADV | 10 | Power-on run | Power-on Run | 1 | Yes | 0-1 | - |

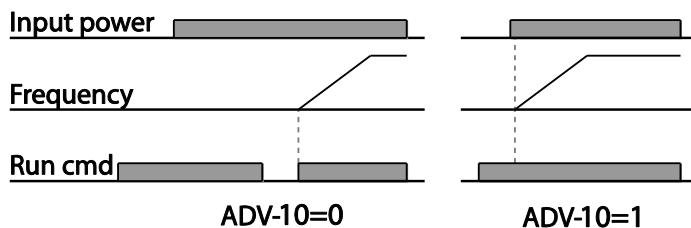

Communication as the command source

To enable power-on resume, set COM-96 (PowerOn Resume) to 'YES', and set DRV-06 to '3 (Int 485)' or '4 (Field Bus)'. If the power input to the inverter is cut off due to a power interruption, the inverter memorizes the run command, frequency reference, and the acc/dec time settings at the time of power interruption. If COM-96 (PowerOn Resume) is set to 'Yes', the inverter starts operating based on these settings as soon as the power supply resumes.

| Group | Code | Name | LCD Display | Settings | | Setting Range | Unit |
|-------|------|-----------------|----------------|----------|-----------|---------------|------|
| | | | | | | | |
| DRV | 06 | Command source | Cmd Source | 3 | Int 485 | 0 - 5 | - |
| | | | | 4 | Field Bus | | |
| COM | 96 | Power-on resume | PowerOn Resume | 0 | No | 0 - 1 | - |
| | | | | 1 | Yes | | |

Note

- To prevent a repeat fault trip from occurring, set CON-71 (speed search options) bit 4 the same as bit 1. The inverter will perform a speed search at the beginning of the operation.
- If the speed search is not enabled, the inverter will start its operation in a normal V/F pattern and accelerate the motor. If the inverter has been turned on without 'reset and restart' enabled, the terminal block command must be first turned off, and then turned on again to begin the inverter's operation.

⚠ Caution

Use caution when operating the inverter with Power-on Run enabled as the motor will begin rotating when the inverter starts up.

4.9 Reset and Restart

Reset and restart operations can be setup for inverter operation following a fault trip, based on the terminal block operation command (if it is configured). When a fault trip occurs, the inverter cuts off the output and the motor will free-run. Another fault trip may be triggered if the inverter begins its operation while motor load is in a free-run state. In PRT-08, bit 1 sets the option for all the fault trips, other than low voltage trips, and bit 2 sets the option for low voltage trips. PRT-10 sets the delay time for restart (the time for the inverter to wait before it restarts).

The number of auto-restarts (PRT-09) refers to the number of times the inverter will try restarting its operation. If fault trips occur again after restart, the retry number counts down each time the inverter restarts until the number becomes '0.' Once the inverter restarts successfully after the initial fault trip, the inverter does not restart until the next fault trip occurs. The number of auto-restarts set at PRT-09 that decreased after a restart reverts to the original setting value if successful operation continues for certain period of time.

| Group | Code | Name | LCD Display | Parameter Setting | | Setting Range | Unit |
|-------|------|-------------------------|--------------|-------------------|---------|---------------|------|
| DRV | 06 | Command source | Cmd Source | 1 | Fx/Rx-1 | 0-5 | - |
| PRT | 08 | Reset restart setup | RST Restart | 00 | | 00-11 | Bit |
| | 09 | No. of auto restart | Retry Number | 6 | | 0-10 | - |
| | 10 | Auto restart delay time | Retry Delay | 5.0 | | 0.1-600.0 | sec |

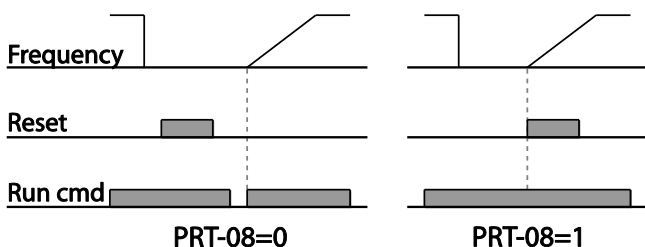

Note

- To prevent a repeat fault trip from occurring, set CON-71 (speed search options) bit 2 the same as bit 1. The inverter will perform a speed search at the beginning of the operation.
- If the speed search is not enabled, the inverter will start its operation in a normal V/F pattern and accelerate the motor. If the inverter has been turned on without 'reset and restart' enabled, the terminal block command must be first turned off, and then turned on again to begin the inverter's operation.

⚠ Caution

Use caution when operating the inverter with Power-on Run enabled as the motor will begin rotating when the inverter starts up.

4.10 Setting Acceleration and Deceleration Times

4.10.1 Acc/Dec Time Based on Maximum Frequency

Acc/Dec time values can be set based on maximum frequency, not on inverter operation frequency. To set Acc/Dec time values based on maximum frequency, set BAS- 08 (Acc/Dec reference) in the Basic group to '0 (Max Freq)'.

Acceleration time set at DRV-03 (Acceleration time) refers to the time required for the inverter to reach the maximum frequency from a stopped (0 Hz) state. Likewise, the value set at the DRV-04 (Deceleration time) refers to the time required to return to a stopped state (0 Hz) from the maximum frequency.

| Group | Code | Name | LCD Display | Parameter Setting | | Setting Range | Unit |
|-------|------|-------------------|-------------|-------------------|-----------|---------------|------|
| DRV | 03 | Acceleration time | Acc Time | 20.0 | 0.75~90KW | 0.0~600.0 | sec |
| | | | | 60.0 | 110~250KW | | |
| | | | | 100.0 | 315~500KW | | |
| | 04 | Deceleration time | Dec Time | 30.0 | 0.75~90KW | 0.0~600.0 | Sec |
| | | | | 90.0 | 110~250KW | | |
| | | | | 150.0 | 315~500KW | | |
| | 20 | Maximum frequency | Max Freq | 60.00 | | 40.00~400.00 | Hz |
| BAS | 08 | Acc/Dec reference | Ramp T Mode | 0 | Max Freq | 0~1 | - |

| Group | Code | Name | LCD Display | Parameter Setting | | Setting Range | Unit |
|-------|------|------------|-------------|-------------------|---------|---------------|------|
| | | frequency | | | | | |
| | 09 | Time scale | Time scale | 1 | 0.1 sec | 0–2 | - |

Acc/Dec Time Based on Maximum Frequency – Setting Details

| Code | Description | | | | | | | | | | | |
|---|---|--|--|---|----------|--|---|------------|--|---|-------|------------------------------------|
| BAS-08 Ramp T Mode | Set the parameter value to 0 (Max Freq) to setup Acc/Dec time based on maximum frequency. | | | | | | | | | | | |
| | <table border="1"> <thead> <tr> <th>Configuration</th> <th>Description</th> </tr> </thead> <tbody> <tr> <td>0</td> <td>Max Freq</td> <td>Set the Acc/Dec time based on maximum frequency.</td> </tr> <tr> <td>1</td> <td>Delta Freq</td> <td>Set the Acc/Dec time based on operating frequency.</td> </tr> </tbody> </table> | Configuration | Description | 0 | Max Freq | Set the Acc/Dec time based on maximum frequency. | 1 | Delta Freq | Set the Acc/Dec time based on operating frequency. | | | |
| | Configuration | Description | | | | | | | | | | |
| | 0 | Max Freq | Set the Acc/Dec time based on maximum frequency. | | | | | | | | | |
| 1 | Delta Freq | Set the Acc/Dec time based on operating frequency. | | | | | | | | | | |
| If, for example, maximum frequency is 60.00 Hz, the Acc/Dec times are set to 5 seconds, and the frequency reference for operation is set at 30 Hz (half of 60 Hz), the time required to reach 30 Hz therefore is 2.5 seconds (half of 5 seconds). | | | | | | | | | | | | |
| | | | | | | | | | | | | |
| BAS-09 Time scale | Use the time scale for all time-related values. It is particularly useful when a more accurate Acc/Dec times are required because of load characteristics, or when the maximum time range needs to be extended. | | | | | | | | | | | |
| | <table border="1"> <thead> <tr> <th>Configuration</th> <th>Description</th> </tr> </thead> <tbody> <tr> <td>0</td> <td>0.01 sec</td> <td>Sets 0.01 second as the minimum unit.</td> </tr> <tr> <td>1</td> <td>0.1 sec</td> <td>Sets 0.1 second as the minimum unit.</td> </tr> <tr> <td>2</td> <td>1 sec</td> <td>Sets 1 second as the minimum unit.</td> </tr> </tbody> </table> | Configuration | Description | 0 | 0.01 sec | Sets 0.01 second as the minimum unit. | 1 | 0.1 sec | Sets 0.1 second as the minimum unit. | 2 | 1 sec | Sets 1 second as the minimum unit. |
| | Configuration | Description | | | | | | | | | | |
| | 0 | 0.01 sec | Sets 0.01 second as the minimum unit. | | | | | | | | | |
| 1 | 0.1 sec | Sets 0.1 second as the minimum unit. | | | | | | | | | | |
| 2 | 1 sec | Sets 1 second as the minimum unit. | | | | | | | | | | |

⚠ Caution

Note that the range of maximum time values may change automatically when the units are changed. If for example, the acceleration time is set at 6000 seconds, a time scale change from 1 second to 0.01 second will result in a modified acceleration time of 60.00 seconds.

4.10.2 Acc/Dec Time Based on Operation Frequency

Acc/Dec times can be set based on the time required to reach the next step frequency from the existing operation frequency. To set the Acc/Dec time values based on the existing operation frequency, set BAS-08 (acc/dec reference) in the Basic group to '1 (Delta Freq)'.

| Group | Code | Name | LCD Display | Settings | | Setting Range | Unit |
|-------|------|-------------------|-------------|----------|------------|---------------|------|
| DRV | 03 | Acceleration time | Acc Time | 20.0 | 0.75~90KW | 0.0 - 600.0 | sec |
| | | | | 60.0 | 110~250KW | | |
| | | | | 100.0 | 315~500KW | | |
| | 04 | Deceleration time | Dec Time | 30.0 | 0.75~90KW | 0.0 - 600.0 | sec |
| | | | | 90.0 | 110~250KW | | |
| | | | | 150.0 | 315~500KW | | |
| BAS | 08 | Acc/Dec reference | Ramp T Mode | 1 | Delta Freq | 0 - 1 | - |

Acc/Dec Time Based on Operation Frequency – Setting Details

| Code | Description | | | | | | |
|--|--|--|-------------|--------------|--|----------------|--|
| BAS-08 Ramp T Mode | Set the parameter value to 1 (Delta Freq) to set Acc/Dec times based on Maximum frequency. | | | | | | |
| | <table border="1"> <thead> <tr> <th>Configuration</th> <th>Description</th> </tr> </thead> <tbody> <tr> <td>0 Max Freq</td> <td>Set the Acc/Dec time based on Maximum frequency.</td> </tr> <tr> <td>1 Delta Freq</td> <td>Set the Acc/Dec time based on Operation frequency.</td> </tr> </tbody> </table> | Configuration | Description | 0 Max Freq | Set the Acc/Dec time based on Maximum frequency. | 1 Delta Freq | Set the Acc/Dec time based on Operation frequency. |
| | Configuration | Description | | | | | |
| | 0 Max Freq | Set the Acc/Dec time based on Maximum frequency. | | | | | |
| | 1 Delta Freq | Set the Acc/Dec time based on Operation frequency. | | | | | |
| If Acc/Dec times are set to 5 seconds, and multiple frequency references are used in the operation in 2 steps, at 10 Hz and 30 Hz, each acceleration stage will take 5 seconds (refer to the graph below). | | | | | | | |
| | | | | | | | |

4.10.3 Multi-step Acc/Dec Time Configuration

Acc/Dec times can be configured via a multi-function terminal by setting the ACC (acceleration time) and DEC (deceleration time) codes in the DRV group.

| Group | Code | Name | LCD Display | Parameter Setting | | Setting Range | Unit |
|-------|-------|--|-----------------------|-------------------|------------|---------------|------|
| DRV | 03 | Acceleration time | Acc Time | 20.0 | 0.75~90KW | 0.0~600.0 | sec |
| | | | | 60.0 | 110~250KW | | |
| | | | | 100.0 | 315~500KW | | |
| | 04 | Deceleration time | Dec Time | 30.0 | 0.75 ~90KW | 0.0~600.0 | sec |
| | | | | 90.0 | 110~250KW | | |
| | | | | 150.0 | 315~500KW | | |
| BAS | 70~83 | Multi-step acceleration/Deceleration time1~7 | Acc Time 1~7 | x.xx | | 0.0~600.0 | sec |
| | | | Dec Time 1~7 | x.xx | | 0.0~600.0 | sec |
| IN | 65~71 | Px terminal configuration | Px Define (Px: P1~P7) | 11 | XCEL-L | 0~55 | - |
| | | | | 12 | XCEL-M | | |
| | | | | 13 | XCEL-H | | |
| | 89 | Multi-step command delay time | In Check Time | 1 | | 1~5000 | ms |

Acc/Dec Time Setup via Multi-function Terminals – Setting Details

| Code | Description | | | | | | | | | | | | | | |
|--|---|-------------------|-------------|-----------|-------------------|-----------|-------------------|-----------|-------------------|---|---|---|---|---|---|
| BAS-70–82 Acc Time 1–7 | Set multi-step acceleration time1–7. | | | | | | | | | | | | | | |
| BAS-71–83 Dec Time 1–7 | Set multi-step deceleration time1–7. | | | | | | | | | | | | | | |
| IN-65–71 Px Define (P1–P7) | Choose and configure the terminals to use for multi-step Acc/Dec time inputs | | | | | | | | | | | | | | |
| | <table border="1"> <thead> <tr> <th>Configuration</th> <th>Description</th> </tr> </thead> <tbody> <tr> <td>11 XCEL-L</td> <td>Acc/Dec command-L</td> </tr> <tr> <td>12 XCEL-M</td> <td>Acc/Dec command-M</td> </tr> <tr> <td>13 XCEL-H</td> <td>Acc/Dec command-H</td> </tr> </tbody> </table> | Configuration | Description | 11 XCEL-L | Acc/Dec command-L | 12 XCEL-M | Acc/Dec command-M | 13 XCEL-H | Acc/Dec command-H | | | | | | |
| | Configuration | Description | | | | | | | | | | | | | |
| | 11 XCEL-L | Acc/Dec command-L | | | | | | | | | | | | | |
| | 12 XCEL-M | Acc/Dec command-M | | | | | | | | | | | | | |
| 13 XCEL-H | Acc/Dec command-H | | | | | | | | | | | | | | |
| Acc/Dec commands are recognized as binary code inputs and will control the acceleration and deceleration based on parameter values set with BAS-70–82 and BAS-71–83. If, for example, the P6 and P7 terminals are set as XCEL-L and XCEL-M respectively, the following operation will be available. | | | | | | | | | | | | | | | |
| | | | | | | | | | | | | | | | |
| <table border="1"> <thead> <tr> <th>Acc/Dec time</th> <th>P7</th> <th>P6</th> </tr> </thead> <tbody> <tr> <td>0</td> <td>-</td> <td>-</td> </tr> <tr> <td>1</td> <td>-</td> <td>✓</td> </tr> <tr> <td>2</td> <td>✓</td> <td>-</td> </tr> <tr> <td>3</td> <td>✓</td> <td>✓</td> </tr> </tbody> </table> | Acc/Dec time | P7 | P6 | 0 | - | - | 1 | - | ✓ | 2 | ✓ | - | 3 | ✓ | ✓ |
| Acc/Dec time | P7 | P6 | | | | | | | | | | | | | |
| 0 | - | - | | | | | | | | | | | | | |
| 1 | - | ✓ | | | | | | | | | | | | | |
| 2 | ✓ | - | | | | | | | | | | | | | |
| 3 | ✓ | ✓ | | | | | | | | | | | | | |
| | [Multi-function terminal P6, P7 configuration] | | | | | | | | | | | | | | |
| IN-89 In Check Time | Set the time for the inverter to check for other terminal block inputs. If IN-89 is set to 100 ms and a signal is supplied to the P6 terminal, the inverter searches for other inputs over the next 100 ms. When the time expires, the Acc/Dec time will be set based on the input received at P6 | | | | | | | | | | | | | | |

4.10.4 Configuring Acc/Dec Time Switch Frequency

You can switch between two different sets of Acc/Dec times (Acc/Dec gradients) by configuring the switch frequency without configuring the multi-function terminals.

| Group | Code | Name | LCD Display | Parameter Setting | | Setting Range | Unit |
|-------|------|-------------------------------|----------------|-------------------|-----------|---------------------|------|
| DRV | 03 | Acceleration time | Acc Time | 20.0 | 0.75~90KW | 0.0~600.0 | sec |
| | | | | 60.0 | 110~250KW | | |
| | | | | 100.0 | 315~500KW | | |
| | 04 | Deceleration time | Dec Time | 30.0 | 0.75~90KW | 0.0~600.0 | sec |
| | | | | 90.0 | 110~250KW | | |
| | | | | 150.0 | 315~500KW | | |
| BAS | 70 | Multi-step acceleration time1 | Acc Time-1 | 20.0 | | 0.0~600.0 | sec |
| | 71 | Multi-step deceleration time1 | Dec Time-1 | 20.0 | | 0.0~600.0 | sec |
| ADV | 60 | Acc/Dec time switch frequency | Xcel Change Fr | 30.00 | | 0~Maximum frequency | Hz |

Acc/Dec Time Switch Frequency Setting Details

| Code | Description |
|--------------------------|--|
| ADV-60 Xcel Change Fr | <p>After the Acc/Dec switch frequency has been set, Acc/Dec gradients configured at BAS-70 and 71 will be used when the inverter's operation frequency is at or below the switch frequency. If the operation frequency exceeds the switch frequency, the gradient level configured for the acceleration and deceleration times (set at DRV-03 and DRV-04) will be used.</p> <p>If you configure the P1~P7 multi-function input terminals for multi-step Acc/Dec gradients (XCEL-L, XCEL-M, XCEL-H), the inverter will operate based on the Acc/Dec inputs at the terminals instead of the Acc/Dec switch frequency configurations.</p> <p>The 'Xcel Change Fr' parameter is applied only when ADV-24 (Freq Limit Mode) is set to 'NO'.</p> |

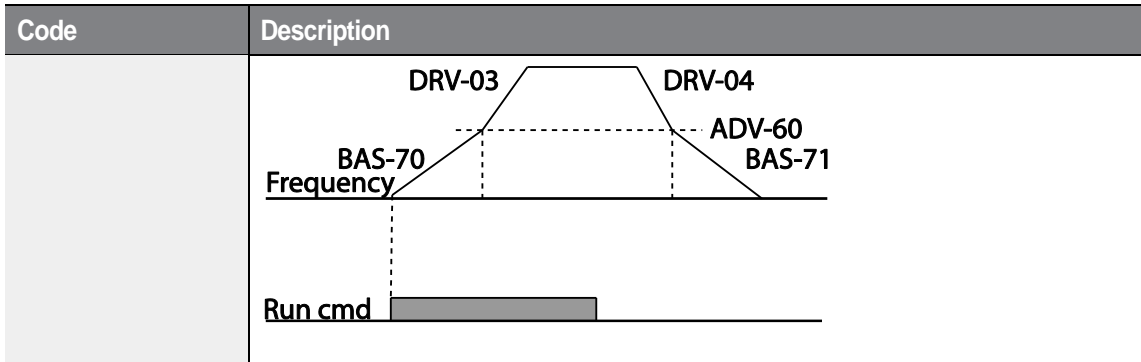

4.11 Acc/Dec Pattern Configuration

Acc/Dec gradient level patterns can be configured to enhance and smooth the inverter’s acceleration and deceleration curves. Linear pattern features a linear increase or decrease to the output frequency, at a fixed rate. For an S-curve pattern a smoother and more gradual increase or decrease of output frequency, ideal for lift-type loads or elevator doors, etc. S-curve gradient level can be adjusted using codes ADV-03–06 in the advanced group.

| Group | Code | Name | LCD Display | Parameter Setting | | Setting Range | Unit |
|-------|------|----------------------------|-------------|-------------------|----------|---------------|------|
| BAS | 08 | Acc/Dec reference | Ramp T mode | 0 | Max Freq | 0–1 | - |
| ADV | 01 | Acceleration pattern | Acc Pattern | 0 | Linear | 0–1 | - |
| | 02 | Deceleration pattern | Dec Pattern | 1 | S-curve | | - |
| | 03 | S-curve Acc start gradient | Acc S Start | 40 | | 1–100 | % |
| | 04 | S-curve Acc end gradient | Acc S End | 40 | | 1–100 | % |
| | 05 | S-curve Dec start gradient | Dec S Start | 40 | | 1–100 | % |
| | 06 | S-curve Dec end gradient | Dec S End | 40 | | 1–100 | % |

Acc/Dec Pattern Setting Details

| Code | Description |
|--|---|
| ADV-03 Acc S Start | <p>Sets the gradient level as acceleration starts when using an S-curve, Acc/Dec pattern. ADV-03 defines S-curve gradient level as a percentage, up to half of total acceleration.</p> <p>If the frequency reference and maximum frequency are set at 60 Hz and ADV-03 is set to 50%, ADV-03 configures acceleration up to 30 Hz (half of 60 Hz). The inverter will operate S-curve acceleration in the 0-15 Hz frequency range (50% of 30 Hz). Linear acceleration will be applied to the remaining acceleration within the 15–30 Hz frequency range.</p> |
| ADV-04 Acc S End | <p>Sets the gradient level as acceleration ends when using an S-curve Acc/Dec pattern. ADV-03 defines S-curve gradient level as a percentage, above half of total acceleration.</p> <p>If the frequency reference and the maximum frequency are set at 60 Hz and ADV-04 is set to 50%, setting ADV-04 configures acceleration to increase from 30 Hz (half of 60 Hz) to 60 Hz (end of acceleration). Linear acceleration will be applied within the 30-45 Hz frequency range. The inverter will perform an S-curve acceleration for the remaining acceleration in the 45–60 Hz frequency range.</p> |
| ADV-05 Dec S Start – ADV-06 Dec S End | <p>Sets the rate of S-curve deceleration. Configuration for codes ADV-05 and ADV-06 may be performed the same way as configuring codes ADV-03 and ADV-04.</p> |

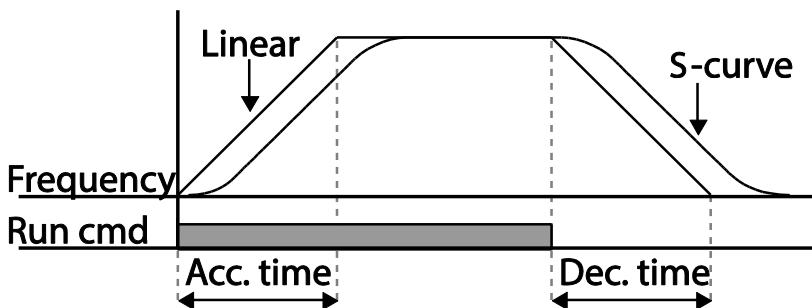

[Acceleration / deceleration pattern configuration]

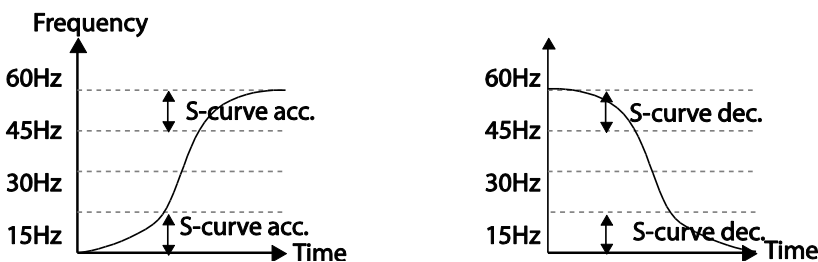
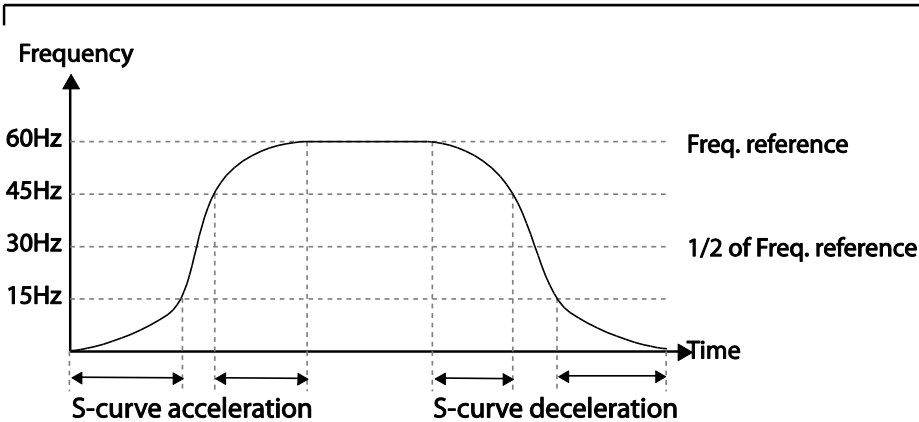

[Acceleration / deceleration S-curve pattern configuration]

Note

The Actual Acc/Dec time during an S-curve application

Actual acceleration time = user-configured acceleration time + user-configured acceleration time x starting gradient level/2 + user-configured acceleration time x ending gradient level/2.
 Actual deceleration time = user-configured deceleration time + user-configured deceleration time x starting gradient level/2 + user-configured deceleration time x ending gradient level/2.

⚠ Caution

Note that actual Acc/Dec times become greater than user defined Acc/Dec times when S-curve Acc/Dec patterns are in use.

4.12 Stopping the Acc/Dec Operation

Configure the multi-function input terminals to stop acceleration or deceleration and operate the inverter at a fixed frequency.

| Group | Code | Name | LCD Display | Parameter Setting | | Setting Range | Unit |
|-------|-------|---------------------------|------------------------|-------------------|-----------|---------------|------|
| IN | 65-71 | Px terminal configuration | Px Define (Px: P1- P7) | 14 | XCEL Stop | 0-55 | - |

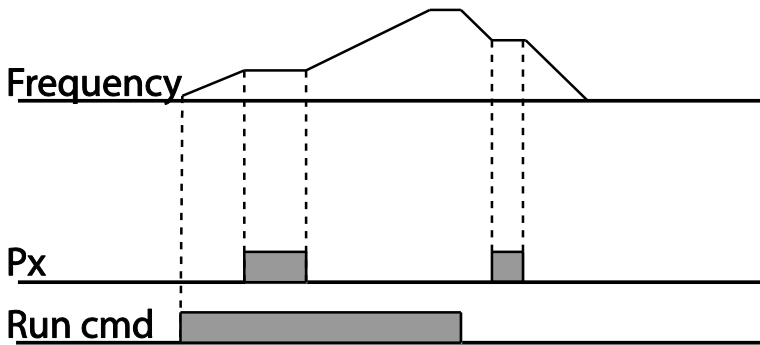

4.13 V/F (Voltage/Frequency) Control

Configure the inverter's output voltages, gradient levels, and output patterns to achieve a target output frequency with V/F control. The amount of torque boost used during low frequency operations can also be adjusted.

4.13.1 Linear V/F Pattern Operation

A linear V/F pattern configures the inverter to increase or decrease the output voltage at a fixed rate for different operation frequencies based on V/F characteristics. A linear V/F pattern is particularly useful when a constant torque load is applied.

| Group | Code | Name | LCD Display | Parameter Setting | Setting Range | Unit |
|-------|------|-----------------|--------------|-------------------|---------------|------|
| IN | 09 | Control mode | Control Mode | 0 V/F | 0–1 | - |
| | 18 | Base frequency | Base Freq | 60.00 | 30.00–400.00 | Hz |
| | 19 | Start frequency | Start Freq | 0.50 | 0.01–10.00 | Hz |
| BAS | 07 | V/F pattern | V/F Pattern | 0 Linear | 0–3 | - |

Linear V/F Pattern Setting Details

| Code | Description |
|-------------------|---|
| DRV-18 Base Freq | Sets the base frequency. A base frequency is the inverter's output frequency when running at its rated voltage. Refer to the motor's rating plate to set this parameter value. |
| DRV-19 Start Freq | <p>Sets the start frequency. A start frequency is a frequency at which the inverter starts voltage output. The inverter does not produce output voltage while the frequency reference is lower than the set frequency. However, if a deceleration stop is made while operating above the start frequency, output voltage will continue until the operation frequency reaches a full-stop (0 Hz).</p> <p>The diagram illustrates the relationship between Frequency, Inverter's rated voltage, and Run cmd. The Frequency waveform starts at a low value, rises linearly to a 'Start Freq' level, then continues to rise linearly to a 'Base Freq' level, remains constant at Base Freq for a period, and then falls linearly. The Inverter's rated voltage waveform follows a similar pattern, starting at zero, rising linearly to a constant level during the Base Freq period, and then falling linearly. The Run cmd waveform is a single pulse that occurs during the rising and constant portions of the frequency and voltage waveforms.</p> |

4.13.2 Square Reduction V/F Pattern Operation

Square reduction V/F pattern is ideal for loads such as fans and pumps. It provides non-linear acceleration and deceleration patterns to sustain torque throughout the whole frequency range.

| Group | Code | Name | LCD Display | Parameter Setting | | Setting Range | Unit |
|-------|------|-------------|-------------|-------------------|---------|---------------|------|
| BAS | 07 | V/F pattern | V/F Pattern | 1 | Square | 0-3 | - |
| | | | | 3 | Square2 | | |

Square Reduction V/F pattern Operation - Setting Details

| Code | Description | | | | | | |
|--------------------|---|----------|----------|---|---|---|---|
| BAS-07 V/F Pattern | Sets the parameter value to '1 (Square)' or '2 (Square2)' according to the load's start characteristics. | | | | | | |
| | <table border="1"> <thead> <tr> <th>Setting</th> <th>Function</th> </tr> </thead> <tbody> <tr> <td>1</td> <td>Square The inverter produces output voltage proportional to 1.5 square of the operation frequency.</td> </tr> <tr> <td>3</td> <td>Square2 The inverter produces output voltage proportional to 2 square of the operation frequency. This setup is ideal for variable torque loads such as fans or pumps.</td> </tr> </tbody> </table> | Setting | Function | 1 | Square The inverter produces output voltage proportional to 1.5 square of the operation frequency. | 3 | Square2 The inverter produces output voltage proportional to 2 square of the operation frequency. This setup is ideal for variable torque loads such as fans or pumps. |
| | Setting | Function | | | | | |
| 1 | Square The inverter produces output voltage proportional to 1.5 square of the operation frequency. | | | | | | |
| 3 | Square2 The inverter produces output voltage proportional to 2 square of the operation frequency. This setup is ideal for variable torque loads such as fans or pumps. | | | | | | |

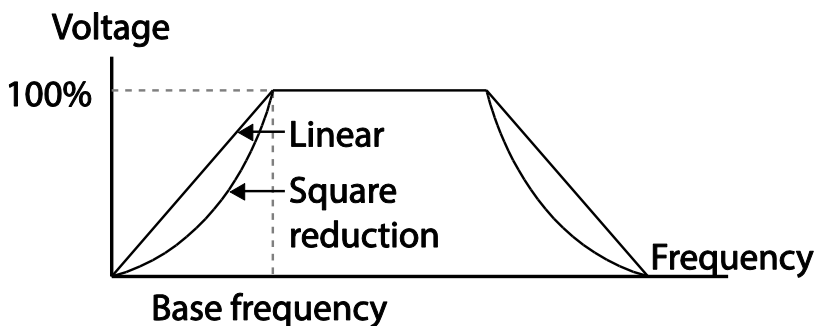

4.13.3 User V/F Pattern Operation

The H100 inverter allows the configuration of user-defined V/F patterns to suit the load characteristics of special motors.

| Group | Code | Name | LCD Display | Parameter Setting | | Setting Range | Unit |
|-------|------|------------------|-------------|-------------------|----------|---------------------|------|
| BAS | 07 | V/F pattern | V/F Pattern | 2 | User V/F | 0–3 | - |
| | 41 | User Frequency 1 | User Freq 1 | 15.00 | | 0–Maximum frequency | Hz |
| | 42 | User Voltage 1 | User Volt 1 | 25 | | 0–100% | % |
| | 43 | User Frequency 2 | User Freq 2 | 30.00 | | 0–Maximum frequency | Hz |
| | 44 | User Voltage 2 | User Volt 2 | 50 | | 0–100% | % |
| | 45 | User Frequency 3 | User Freq 3 | 45.00 | | 0–Maximum frequency | Hz |
| | 46 | User Voltage 3 | User Volt 3 | 75 | | 0–100% | % |
| | 47 | User Frequency 4 | User Freq 4 | Maximum frequency | | 0–Maximum frequency | Hz |
| | 48 | User Voltage 4 | User Volt 4 | 100 | | 0–100% | % |

User V/F pattern Setting Details

| Code | Description |
|--|--|
| BAS-41 User Freq 1 –BAS-48 User Volt 4 | Set the parameter values to assign arbitrary frequencies (User Freq x) for start and maximum frequencies. Voltages can also be set to correspond with each frequency, and for each user voltage (User Volt x). |

The 100% output voltage in the figure below is based on the parameter settings of BAS-15 (motor rated voltage). If BAS-15 is set to '0' it will be based on the input voltage.

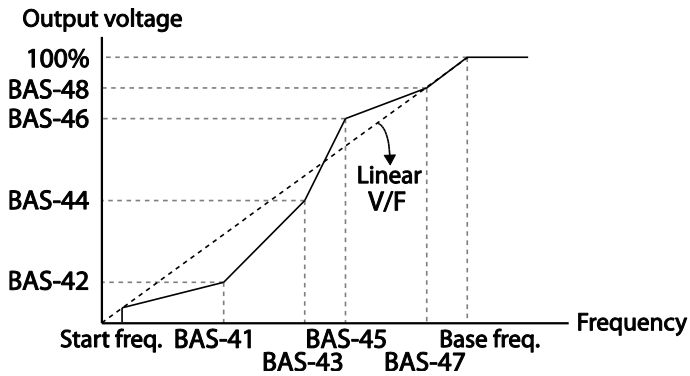

⚠ Caution

- When a normal induction motor is in use, care must be taken not to configure the output pattern away from a linear V/F pattern. Non-linear V/F patterns may cause insufficient motor torque or motor overheating due to over-excitation.
- When a user V/F pattern is in use, forward torque boost (DRV-16) and reverse torque boost (DRV-17) do not operate.

4.14 Torque Boost

4.14.1 Manual Torque Boost

Manual torque boost enables users to adjust output voltage during low speed operation or motor start. Increase low speed torque or improve motor starting properties by manually increasing output voltage. Configure manual torque boost while running loads that require high starting torque, such as lift-type loads.

| Group | Code | Name | LCD Display | Parameter Setting | | Setting Range | Unit |
|-------|------|----------------------|--------------|-------------------|-----------|---------------|------|
| DRV | 15 | Torque boost options | Torque Boost | 0 | Manual | 0-2 | - |
| | 16 | Forward torque boost | Fwd Boost | 2.0 | 0.75~90kW | 0.0-15.0 | % |
| | | | | 1.0 | 110~500kW | | |
| | 17 | Reverse torque boost | Rev Boost | 2.0 | 0.75~90kW | 0.0-15.0 | % |
| | | | | 1.0 | 110~500kW | | |

Manual Torque Boost Setting Details

| Code | Description |
|------------------|---|
| DRV-16 Fwd Boost | Set torque boost for forward operation. |
| DRV-17 Rev Boost | Set torque boost for reverse operation. |

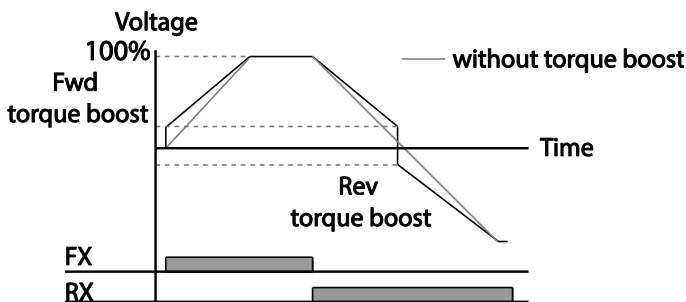

⚠ Caution

Excessive torque boost will result in over-excitation and motor overheating

4.14.2 Auto Torque Boost

Set DRV-15 to 'Auto 1' or 'Auto 2' to select the type of torque boost. While manual torque boost adjusts the inverter output based on the setting values regardless of the type of load used in the operation, auto torque boost enables the inverter to automatically calculate the amount of output voltage required for torque boost based on the entered motor parameters. Because auto torque boost requires motor-related parameters such as stator resistance, inductance, and no-load current, auto tuning (BAS-20) has to be performed before auto torque boost can be configured. Similarly to manual torque boost, configure auto torque boost while running a load that requires high starting torque, such as lift-type loads. Refer to [5.21 Auto Tuning](#) on page [210](#).

| Group | Code | Name | LCD Display | Parameter Setting | | Setting Range | Unit |
|-------|------|-------------------|--------------|-------------------|-----------|---------------|------|
| DRV | 15 | torque boost mode | Torque Boost | 1 | Auto 1 | 0-2 | - |
| BAS | 20 | auto tuning | Auto Tuning | 3 | Rs+Lsigma | 0-3 | - |

4.14.3 Auto Torque Boost 2 (No Motor Parameter Tuning Required)

By adjusting the auto torque boost voltage gain set at DRV-15 (ATB Volt Gain), automatic torque boost may be operated without tuning the motor-related parameter values. The DRV-15 (ATB Volt Gain) value is used to adjust the amount of compensation required for each load. It prevents stalls or overcurrent fault trips at start up.

| Group | Code | Name | LCD Display | Settings | | Setting Range | Unit |
|-------|------|--------------------------------|---------------|----------|--------|---------------|------|
| DRV | 15 | Torque boost mode | Torque Boost | 2 | Auto 2 | 0-2 | - |
| CON | 21 | Auto torque boost filter gain | ATB Filt Gain | 10 | | 1 - 9999 | msec |
| CON | 22 | Auto torque boost voltage gain | ATB Volt Gain | 100.0 | | 0 - 300.0 | % |

4.15 Output Voltage Setting

Output voltage settings are required when a motor's rated voltage differs from the input voltage to the inverter. Set BAS-15 to configure the motor's rated operating voltage. The set voltage becomes the output voltage of the inverter's base frequency. When the inverter operates above the base frequency, and when the motor's voltage rating is lower than the input voltage at the inverter, the inverter adjusts the voltage and supplies the motor with the voltage set at BAS-15 (motor rated voltage). If the motor's rated voltage is higher than the input voltage at the inverter, the inverter will supply the inverter input voltage to the motor.

If BAS-15 (motor rated voltage) is set to '0', the inverter corrects the output voltage based on the input voltage in the stopped condition. If the frequency is higher than the base frequency, when the input voltage is lower than the parameter setting, the input voltage will be the inverter output voltage.

| Group | Code | Name | LCD Display | Parameter Setting | Setting Range | Unit |
|-------|------|---------------------|-------------|-------------------|---------------|------|
| BAS | 15 | Motor rated voltage | Rated Volt | 0 | 170–480 | V |

Output voltage

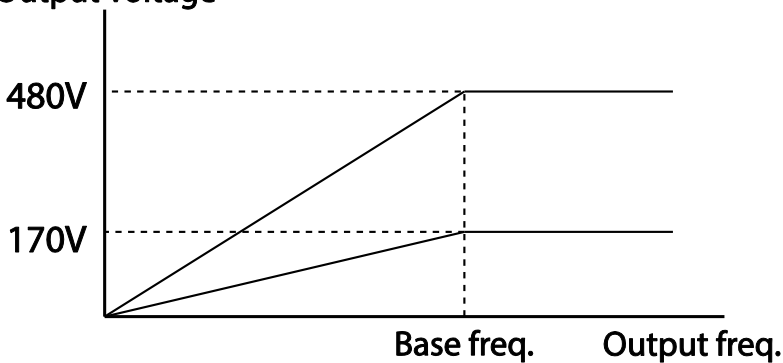

4.16 Start Mode Setting

Select the start mode to use when the operation command is input with the motor in the stopped condition.

4.16.1 Acceleration Start

Acceleration start is a general acceleration mode. If there are no extra settings applied, the motor accelerates directly to the frequency reference when the command is input.

| Group | Code | Name | LCD Display | Parameter Setting | | Setting Range | Unit |
|-------|------|------------|-------------|-------------------|-----|---------------|------|
| ADV | 07 | Start mode | Start mode | 0 | Acc | 0–1 | - |

4.16.2 Start After DC Braking

This start mode supplies a DC voltage for a set amount of time to provide DC braking before an inverter starts to accelerate a motor. If the motor continues to rotate due to its inertia, DC braking will stop the motor, allowing the motor to accelerate from a stopped condition. DC braking can also be used with a mechanical brake connected to a motor shaft when a constant torque load is applied, if a constant torque is required after the the mechanical brake is released.

| Group | Code | Name | LCD Display | Parameter Setting | | Setting Range | Unit |
|-------|------|-----------------------|---------------|-------------------|----------|---------------|------|
| ADV | 07 | Start mode | Start Mode | 1 | DC-Start | 0–1 | - |
| | 12 | Start DC braking time | DC-Start Time | 0.00 | | 0.00–60.00 | sec |
| | 13 | DC Injection Level | DC Inj Level | 50 | | 0–200 | % |

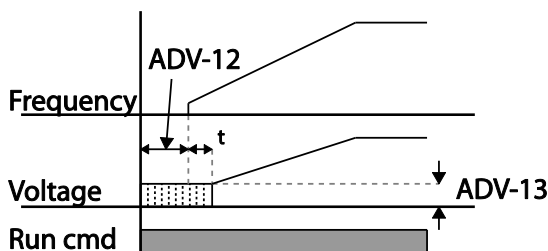

⚠ Caution

The amount of DC braking required is based on the motor's rated current. Do not use DC braking resistance values that can cause current draw to exceed the rated current of the inverter. If the DC braking resistance is too high or brake time is too long, the motor may overheat or be damaged

4.17 Stop Mode Setting

Select a stop mode to stop the inverter operation.

4.17.1 Deceleration Stop

Deceleration stop is a general stop mode. If there are no extra settings applied, the motor decelerates down to 0 Hz and stops, as shown in the figure below.

| Group | Code | Name | LCD Display | Parameter Setting | | Setting Range | Unit |
|-------|------|-----------|-------------|-------------------|-----|---------------|------|
| ADV | 08 | Stop mode | Stop Mode | 0 | Dec | 0–4 | - |

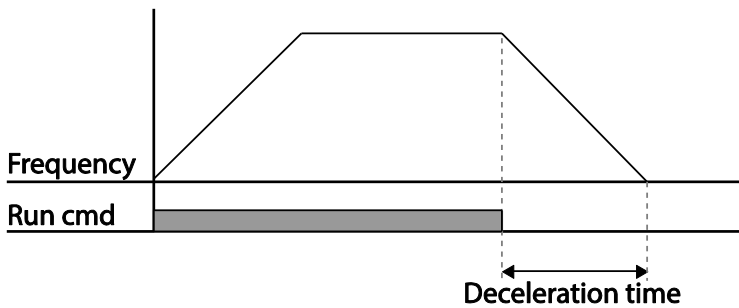

4.17.2 Stop After DC Braking

When the operation frequency reaches the set value during deceleration (DC braking frequency) the inverter stops the motor by supplying DC power to the motor. With a stop command input, the inverter begins decelerating the motor. When the frequency reaches the DC braking frequency set at ADV-17, the inverter supplies DC voltage to the motor and stops it.

| Group | Code | Name | LCD Display | Parameter Setting | | Setting Range | Unit |
|-------|----------------------|----------------------------------|----------------|-------------------|------------|---------------|------|
| ADV | 08 | Stop mode | Stop Mode | 1 | DC Brake | 0-4 | - |
| | 14 | Output block time before braking | DC-Block Time | 0.00 | 0.75~90kW | 0.00-60.00 | sec |
| | | | | 2.00 | 110~500kW | | |
| | 15 | DC braking time | DC-Brake Time | 1.00 | | 0-60 | sec |
| | 16 | DC braking amount | DC-Brake Level | 50 | | 0-200 | % |
| 17 | DC braking frequency | DC-Brake Freq | 5.00 | | 0.00-60.00 | Hz | |

DC Braking After Stop Setting Details

| Code | Description |
|-----------------------|---|
| ADV-14 DC-Block Time | Set the time to block the inverter output before DC braking. If the inertia of the load is great, or if DC braking frequency (ADV-17) is set too high, a fault trip may occur due to overcurrent conditions when the inverter supplies DC voltage to the motor. Prevent overcurrent fault trips by adjusting the output block time before DC braking. |
| ADV-15 DC-Brake Time | Set the time duration for the DC voltage supply to the motor. |
| ADV-16 DC-Brake Level | Set the amount of DC braking to apply. The parameter setting is based on the rated current of the motor. |
| ADV-17 DC-Brake Freq | Set the frequency to start DC braking. When the frequency is reached, the inverter starts deceleration. If the dwell frequency is set lower than the DC braking frequency, dwell operation will not work and DC braking will start instead. |

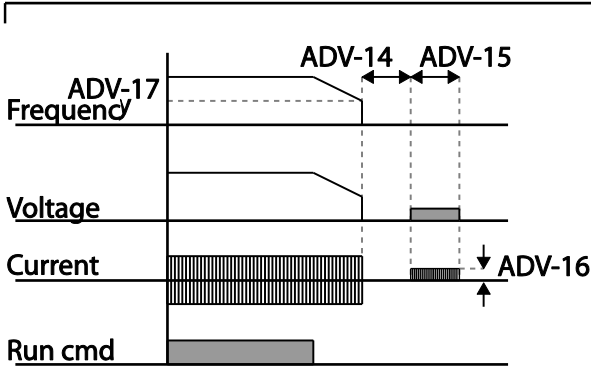

⚠ Caution

- Note that the motor can overheat or be damaged if excessive amount of DC braking is applied to the motor or DC braking time is set too long.
- DC braking is configured based on the motor’s rated current. To prevent overheating or damaging motors, do not set the current value higher than the inverter’s rated current.

4.17.3 Free Run Stop

When the Operation command is off, the inverter output turns off, and the load stops due to residual inertia.

| Group | Code | Name | LCD Display | Parameter Setting | Setting Range | Unit |
|-------|------|-------------|-------------|-------------------|---------------|------|
| ADV | 08 | Stop Method | Stop mode | 2 Free-Run | 0–4 | - |

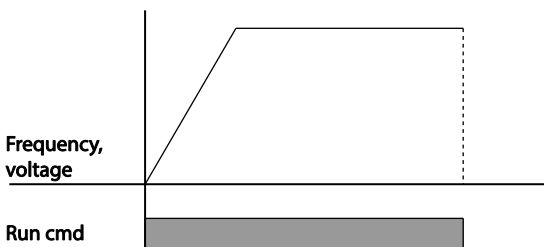

⚠ Caution

Note that when there is high inertia on the output side and the motor is operating at high speed, the load’s inertia will cause the motor to continue rotating even if the inverter output is blocked

4.17.4 Power Braking

When the inverter's DC voltage rises above a specified level due to motor regenerated energy a control is made to either adjust the deceleration gradient level or reaccelerate the motor in order to reduce the regenerated energy. Power braking can be used when short deceleration times are needed without brake resistors, or when optimum deceleration is needed without causing an over voltage fault trip.

| Group | Code | Name | LCD Display | Parameter Setting | | Setting Range | Unit |
|-------|------|-----------|-------------|-------------------|---------------|---------------|------|
| ADV | 08 | Stop mode | Stop Mode | 4 | Power Braking | 0–4 | - |

⚠ Caution

- To prevent overheating or damaging the motor, do not apply power braking to the loads that require frequent deceleration.
- Stall prevention and power braking only operate during deceleration, and power braking takes priority over stall prevention. In other words, when both bit 3 of PRT-50 (stall prevention and flux braking) and ADV-08 (braking options) are set, power braking will take precedence and operate.
- Note that if deceleration time is too short or inertia of the load is too great, an overvoltage fault trip may occur.
- Note that if a free run stop is used, the actual deceleration time can be longer than the pre-set deceleration time.

4.18 Frequency Limit

Operation frequency can be limited by setting maximum frequency, start frequency, upper limit frequency, and lower limit frequency.

4.18.1 Frequency Limit Using Maximum Frequency and Start Frequency

| Group | Code | Name | LCD Display | Parameter Setting | Setting Range | Unit |
|-------|------|-------------------|-------------|-------------------|---------------|------|
| DRV | 19 | Start frequency | Start Freq | 0.50 | 0.01–10.00 | Hz |
| | 20 | Maximum frequency | Max Freq | 60.00 | 40.00–400.00 | Hz |

Frequency Limit Using Maximum Frequency and Start Frequency - Setting Details

| Code | Description |
|-------------------|--|
| DRV-19 Start Freq | Set the lower limit value for speed unit parameters that are expressed in Hz or rpm. If an input frequency is lower than the start frequency, the parameter value will be 0.00. |
| DRV-20 Max Freq | <p>Set upper and lower frequency limits. All frequency selections are restricted to frequencies from within the upper and lower limits. This restriction also applies when you input a frequency reference using the keypad.</p> <p>If you use a high speed motor over 60Hz, there will be individual response due to the difference in characteristics. Please contact LS ELECTRIC.</p> |

4.18.2 Frequency Limit Using Upper and Lower Limit Frequency Values

| Group | Code | Name | LCD Display | Parameter Setting | | Setting Range | Unit |
|-------|------|-----------------------------|---------------|-------------------|----|---------------------------|------|
| ADV | 24 | Frequency limit | Freq Limit | 0 | No | 0–1 | - |
| | 25 | Frequency lower limit value | Freq Limit Lo | 0.50 | | 0.0–maximum frequency | Hz |
| | 26 | Frequency upper limit value | Freq Limit Hi | Maximum frequency | | minimum–maximum frequency | Hz |

Frequency Limit Using Upper and Lower Limit Frequencies - Setting Details

| Code | Description |
|--|---|
| ADV-24 Freq Limit | The initial setting is '0 (No)'. Changing the setting to '1 (Yes)' allows the setting of frequencies between the lower limit frequency (ADV-25) and the upper limit frequency (ADV-26). |
| ADV-25 Freq Limit Lo ADV-26 Freq Limit Hi | Set an upper limit frequency to all speed unit parameters that are expressed in Hz or rpm, except for the base frequency (DRV-18). Frequency cannot be set higher. |

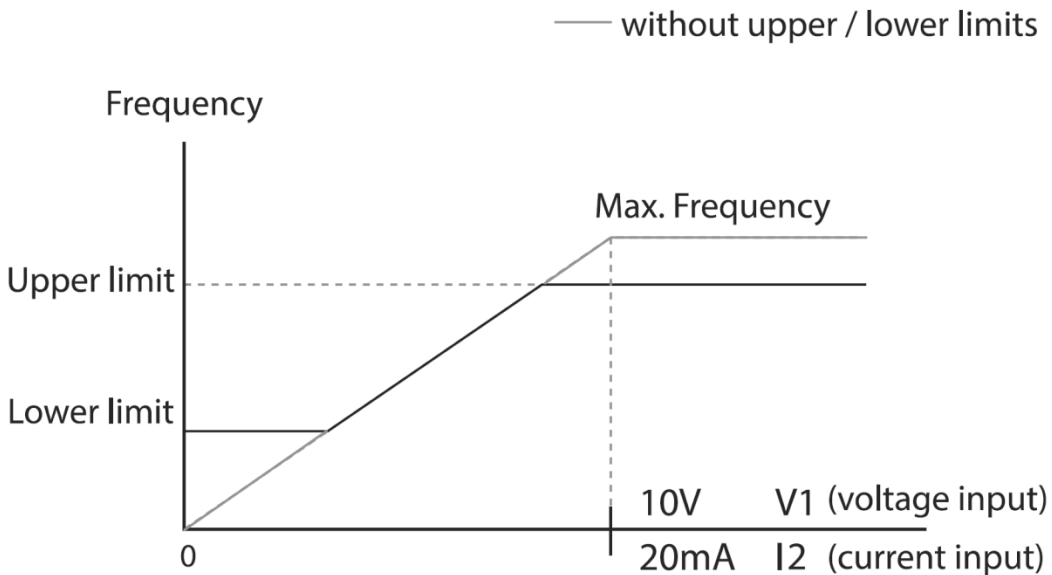

⚠ Caution

- When ADV-24 (Freq Limit) is set to 'Yes,' the frequency set at ADV-25 (Freq Limit Lo) is the minimum frequency (Low Freq). If ADV-24 (Freq Limit) is set to 'No,' the frequency set at DRV-19 (Start Freq) becomes the minimum frequency.
- When ADV-24 (Freq Limit) is set to 'Yes,' the frequency set at ADV-26 (Freq Limit Hi) is the maximum frequency (High Freq). If ADV-24 (Freq Limit) is set to 'No,' the frequency set at DRV-20 (Max Freq) becomes the maximum frequency.

4.18.3 Frequency Jump

Use frequency jump to avoid mechanical resonance frequencies. The inverter will avoid identified ranges during acceleration and deceleration. Operation frequencies cannot be set within the pre-set frequency jump band.

When a frequency setting is increased, while the frequency parameter setting value (voltage, current, RS-485 communication, keypad setting, etc.) is within a jump frequency band the frequency will be maintained at the lower limit value of the frequency band. Then, the frequency will increase when the frequency parameter setting exceeds the range of frequencies used by the frequency jump band.

| Group | Code | Name | LCD Display | Parameter Setting | Setting Range | Unit |
|-------|------|------------------------------|-------------|-------------------|--|------|
| ADV | 27 | Frequency jump | Jump Freq | 0-1 | 0-1 | - |
| | 28 | Jump frequency lower limit1 | Jump Lo 1 | 10.00 | 0.00-Jump frequency upper limit 1 | Hz |
| | 29 | Jump frequency upper limit1 | Jump Hi 1 | 15.00 | Jump frequency lower limit 1-Maximum frequency | Hz |
| | 30 | Jump frequency lower limit 2 | Jump Lo 2 | 20.00 | 0.00-Jump frequency upper limit 2 | Hz |
| | 31 | Jump frequency upper limit 2 | Jump Hi 2 | 25.00 | Jump frequency lower limit 2-Maximum frequency | Hz |
| | 32 | Jump frequency lower limit 3 | Jump Lo 3 | 30.00 | 0.00-Jump frequency upper limit 3 | Hz |
| | 33 | Jump frequency upper limit 3 | Jump Hi 3 | 35.00 | Jump frequency lower limit 3-Maximum frequency | Hz |

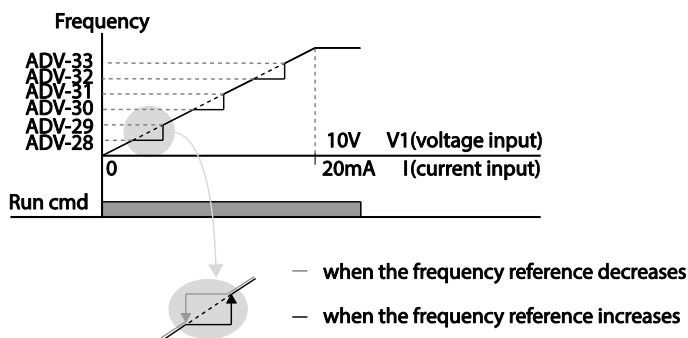

4.19 2nd Operation Mode Setting

Apply two types of operation modes and switch between them as required. For both the first and second command source, set the frequency after shifting operation commands to the multi-function input terminal. Mode switching can be used to stop remote control during an operation using the communication option and to switch operation mode to operate via the local panel, or to operate the inverter from another remote control location.

Select one of the multi-function terminals from codes IN-65–71 and set the parameter value to 15 (2nd Source).

| Group | Code | Name | LCD Display | Parameter Setting | | Setting Range | Unit |
|-------|-------|--------------------------------|-----------------------|-------------------|------------|---------------|------|
| DRV | 06 | Command source | Cmd Source | 1 | Fx/Rx-1 | 0–5 | - |
| | 07 | Frequency reference source | Freq Ref Src | 2 | V1 | 0–11 | - |
| BAS | 04 | 2nd Command source | Cmd 2nd Src | 0 | Keypad | 0–5 | - |
| | 05 | 2nd Frequency reference source | Freq 2nd Src | 0 | KeyPad-1 | 0–11 | - |
| IN | 65–71 | Px terminal configuration | Px Define (Px: P1–P7) | 17 | 2nd Source | 0–55 | - |

2nd Operation Mode Setting Details

| Code | Description |
|---|--|
| BAS-04 Cmd 2nd Src BAS-05 Freq 2nd Src | If signals are provided to the multi-function terminal set as the 2 nd command source (2nd Source), the operation can be performed using the set values from BAS-04-05 instead of the set values from the DRV-7 and DRV-01. The 2nd command source settings cannot be changed while operating with the 1 st command source (Main Source). |

⚠ Caution

- When setting the multi-function terminal to the 2nd command source (2nd Source) and input (On) the signal, operation state is changed because the frequency setting and the Operation command will be changed to the 2nd command. Before shifting input to the multi-function terminal, ensure that the 2nd command is correctly set. Note that if the deceleration time is too short or inertia of the load is too high, an overvoltage fault trip may occur.
- Depending on the parameter settings, the inverter may stop operating when you switch the command modes.





4.20 Multi-function Input Terminal Control

Filter time constants and the type of multi-function input terminals can be configured to improve the response of input terminals.

| Group | Code | Name | LCD Display | Parameter Setting | Setting Range | Unit |
|-------|------|--|--------------|-------------------|---------------|------|
| IN | 85 | Multi-function input terminal On filter | DI On Delay | 10 | 0–10000 | msec |
| | 86 | Multi-function input terminal Off filter | DI Off Delay | 3 | 0–10000 | msec |
| | 87 | Multi-function input terminal selection | DI NC/NO Sel | 000 0000* | - | - |
| | 90 | Multi-function input terminal status | DI Status | 000 0000* | - | - |

* From the last bit to the first, the bits are for multi-purpose input 1–7 (the last bit is for input 1, and the first bit for input 7).

Multi-function Input Terminal Control Setting Details

| Code | Description | | |
|---------------------------------------|--|---|---|
| IN-85 DI On Delay, IN-86 DI Off Delay | If the input terminal's state is not changed during the set time, when the terminal receives an input, it is recognized as On or Off. | | |
| IN-87 DI NC/NO Sel | Select terminal contact types for each input terminal. The position of the indicator light corresponds to the segment that is on as shown in the table below. With the bottom segment on, it indicates that the terminal is configured as a A terminal (Normally Open) contact. With the top segment on, it indicates that the terminal is configured as a B terminal (Normally Closed) contact. Terminals are numbered P1–P7, from right to left. | | |
| | Type | B terminal status (Normally Closed) | A terminal status (Normally Open) |
| | Keypad |  |  |
| IN-90 DI Status | Display the configuration of each contact. When a segment is configured as A terminal, using DRV-87, the On condition is indicated by the top segment turning on. The Off condition is indicated when the bottom segment is turned on. When contacts are configured as B terminals, the segment lights behave conversely. Terminals are numbered P1–P7, from right to left. | | |
| | Type | A terminal setting (On) | A terminal setting (Off) |
| | Keypad |  |  |

4.21 Multi-function Input Terminal On/Off Delay Control

Availability of using On/Off Delay about Multi-function Input Terminal can be set

| Group | Code | Name | LCD Display | Parameter Setting | Setting Range | Unit |
|-------|------|--|----------------|-------------------|---------------------|------|
| IN | 83 | Availability of applying DI On Delay. | DI On DelayEn | 111 1111 | 000 0000 ~ 111 1111 | - |
| | 84 | Availability of applying DI Off Delay. | DI Off DelayEn | 111 1111 | 000 0000 ~ 111 1111 | - |

Multi-function Input Terminal On/Off Delay Control Setting Details

| Code | Description |
|---|---|
| IN-83 DI On Delay En IN-84 DI Off Delay En | <p>Every Input Terminal, it is possible to set availability of using On/Off Delay of Input Terminal.</p> <p>From right, Availability of using On/Off Delay about Multi-function Input Terminal can be set with a sequence such as P1~P7.</p> <p>1: Activate D1 On/Off Delay 0: Inactivate D1 On/Off Delay</p> |

5 Learning Advanced Features

This chapter describes the advanced features of the H100 inverter. Check the reference page in the table to see the detailed description for each of the advanced features.

| Advanced Tasks | Description | Ref. |
|-------------------------------|---|------------------------------|
| Auxiliary frequency operation | Use the main and auxiliary frequencies in the predefined formulas to create various operating conditions. Auxiliary frequency operation is ideal for Draw Operation* as this feature enables fine-tuning of operation speeds. | <u>p.143</u> |
| Jog operation | Jog operation is a kind of a manual operation. The inverter operates to a set of parameter settings predefined for Jog operation while the Jog command button is pressed. | <u>p.148</u> |
| Up-down operation | Uses the upper and lower limit value switch output signals (i.e. signals from a flow meter) as Acc/Dec commands to motors. | <u>p.150</u> |
| 3-wire operation | 3-wire operation is used to latch an input signal. This configuration is used to operate the inverter by a push button. | <u>p.152</u> |
| Safety operation mode | This safety feature allows the inverter's operation only after a signal is input to the multi-function terminal designated for the safety operation mode. This feature is useful when extra care is needed in operating the inverter using the multi-purpose terminals. | <u>p.153</u> |
| Dwell operation | Use this feature for the lift-type loads such as elevators, when the torque needs to be maintained while the brakes are applied or released. | <u>p.155</u> |
| Slip compensation | This feature ensures that the motor rotates at a constant speed, by compensating for the motor slip as a load increases. | <u>p.157</u> |
| PID control | PID control provides constant automated control of flow, pressure, and temperature by adjusting the output frequency of the inverter. | <u>p.158</u> |
| Sleep-wakeup operation | When the inverter operation continues below the PID conditions for a set time period, the PID reference is automatically raised to extend the operation standby time. This keeps the inverter in a standby (sleep) mode when the demand is very low. | <u>p.174</u> |
| Auto-tuning | Used to automatically measure the motor control parameters to optimize the inverter's control mode performance. | <u>p.210</u> |
| Energy buffering operation | Used to maintain the DC link voltage for as long as possible by controlling the inverter output frequency during power interruptions, thus to delay a low voltage fault trip. | <u>p.190</u> |
| Energy saving operation | Used to save energy by reducing the voltage supplied to motors during low-load and no-load conditions. | <u>p.229</u> |
| Speed search operation | Used to prevent fault trips when the inverter voltage is output while the motor is idling or free-running. | <u>p.234</u> |

Learning Advanced Features

| Advanced Tasks | Description | Ref. |
|--|---|------------------------------|
| Auto restart operation | Auto restart configuration is used to automatically restart the inverter when a trip condition is released, after the inverter stops operating due to activation of protective devices (fault trips). | <u>p.238</u> |
| Second motor operation | Used to switch equipment operation by connecting two motors to one inverter. Configure and operate the second motor using the terminal input defined for the second motor operation. | <u>p.241</u> |
| Commercial power source switch operation | Used to switch the power source to the motor from the inverter output to a commercial power source, or vice versa. | <u>p.243</u> |
| Cooling fan control | Used to control the cooling fan of the inverter. | <u>p.244</u> |
| Multi-function output On/Off control | Set standard values and turn On/Off the output relays or multi-function output terminals according to the analog input value. | <u>p.282</u> |
| Regeneration prevention for press operation. | Used during a press operation to avoid motor regeneration, by increasing the motor operation speed. | <u>p.243</u> |
| Damper operation | Controls the fan motor optimally when a damper is used in the system. | <u>p.187</u> |
| Lubrication operation | Supplies lubricant to the machinery before starting the inverter and the mechanical system connected to it. | <u>p.189</u> |
| Flow compensation | Compensates for pressure loss in a system with long pipelines. | <u>p.187</u> |
| Energy savings display | Displays the amount of energy saved by the use of the inverter, compared to when a commercial power source is used without an inverter. | <u>p.191</u> |
| Pump clean operation | Cleans the pumps by removing the scales or deposits that are attached to the impeller. | <u>p.192</u> |
| Inclination setting for operation and stop | Sets the initial operating conditions for a pump by adjusting the acceleration and deceleration times. | <u>p.197</u> |
| Valve deceleration time setting | Prevents possible pump damage that may be caused by abrupt deceleration. | <u>p.198</u> |
| Load tuning | Creates load-specific curves for light load operations and the pump clean operation. | <u>p.199</u> |
| Level detection | Detects and displays the level set by the user. | <u>p.202</u> |
| Pipe breakage detection | Detects breakages in the pipeline during a PID operation. | <u>p.206</u> |
| Motor preheating | Prevents motors and pumps from freezing when they are not operated. | <u>p.208</u> |
| Scheduled operation | Uses the built-in real-time clock (RTC) to operate the inverter according to the desired time schedule. | <u>p.213</u> |
| Fire mode operation | Operates the inverter in a way to cope with emergency situations, such as fire, by controlling the operation of ventilation (intake and exhaust) fans. | <u>p.230</u> |

5.1 Operating with Auxiliary References

Frequency references can be configured with various calculated conditions that use the main and auxiliary frequency references simultaneously. The main frequency reference is used as the operating frequency, while auxiliary references are used to modify and fine-tune the main reference.

| Group | Code | LCD Display | LCD Display | Parameter Setting | | Setting Range | Unit |
|-------|-------|--|---------------|-------------------|-------------|---------------|------|
| DRV | 06 | Frequency reference source | Freq Ref Src | 0 | Keypad-1 | 0–11 | - |
| BAS | 01 | Auxiliary frequency reference source | Aux Ref Src | 1 | V1 | 0–13 | - |
| | 02 | Auxiliary frequency reference calculation type | Aux Calc Type | 0 | M+(G*A) | 0–7 | - |
| | 03 | Auxiliary frequency reference gain | Aux Ref Gain | 100.0 | 100.0 | -200.0–200.0 | % |
| IN | 65–71 | Px terminal configuration | Px Define | 36 | dis Aux Ref | 0–55 | - |

The table above lists the available calculated conditions for the main and auxiliary frequency references. Refer to the table to see how the calculations apply to an example where the DRV-06 Frq Src code has been set to '0 (Keypad-1)', and the inverter is operating at a main reference frequency of 30.00 Hz. Signals at -10 to +10 V are received at terminal V1, with the reference gain set at 5%. In this example, the resulting frequency reference is fine-tuned within the range of 27.00–33.00 Hz [Codes IN-01–16 must be set to the default values, and IN-06 (V1 Polarity), set to '1 (Bipolar)'].

Auxiliary Reference Setting Details

| Code | Description | | | | | | | | | | | | | | | | | | | | | | | | | | |
|--|---|---|---|---|-----------------|---|---|-----------------------|--|---|-------------------|---|---|-------------------------------|---|---|--------------------------------|--|---|--|--|---|------------------------------------|--|---|--|--|
| BAS-01 Aux Ref Src | Set the input type to be used for the auxiliary frequency reference. | | | | | | | | | | | | | | | | | | | | | | | | | | |
| | <table border="1"> <thead> <tr> <th>Configuration</th> <th>Description</th> </tr> </thead> <tbody> <tr> <td>0</td> <td>None</td> <td>Auxiliary frequency reference is disabled</td> </tr> <tr> <td>1</td> <td>V1</td> <td>Sets the V1 (voltage) terminal at the control terminal block as the source of auxiliary frequency reference.</td> </tr> <tr> <td>3</td> <td>V2</td> <td>Sets the I2 (voltage) terminal at the control terminal block as the source of auxiliary frequency reference (SW4 must be set to 'voltage').</td> </tr> <tr> <td>4</td> <td>I2</td> <td>Sets the I2 (current) terminal at the control terminal block as the source of auxiliary frequency reference (SW4 must be set to 'current').</td> </tr> <tr> <td>5</td> <td>Pulse</td> <td>Sets the T1 (pulse) terminal at the control terminal block as the source of auxiliary frequency reference.</td> </tr> </tbody> </table> | Configuration | Description | 0 | None | Auxiliary frequency reference is disabled | 1 | V1 | Sets the V1 (voltage) terminal at the control terminal block as the source of auxiliary frequency reference. | 3 | V2 | Sets the I2 (voltage) terminal at the control terminal block as the source of auxiliary frequency reference (SW4 must be set to 'voltage'). | 4 | I2 | Sets the I2 (current) terminal at the control terminal block as the source of auxiliary frequency reference (SW4 must be set to 'current'). | 5 | Pulse | Sets the T1 (pulse) terminal at the control terminal block as the source of auxiliary frequency reference. | | | | | | | | | |
| | Configuration | Description | | | | | | | | | | | | | | | | | | | | | | | | | |
| | 0 | None | Auxiliary frequency reference is disabled | | | | | | | | | | | | | | | | | | | | | | | | |
| | 1 | V1 | Sets the V1 (voltage) terminal at the control terminal block as the source of auxiliary frequency reference. | | | | | | | | | | | | | | | | | | | | | | | | |
| | 3 | V2 | Sets the I2 (voltage) terminal at the control terminal block as the source of auxiliary frequency reference (SW4 must be set to 'voltage'). | | | | | | | | | | | | | | | | | | | | | | | | |
| 4 | I2 | Sets the I2 (current) terminal at the control terminal block as the source of auxiliary frequency reference (SW4 must be set to 'current'). | | | | | | | | | | | | | | | | | | | | | | | | | |
| 5 | Pulse | Sets the T1 (pulse) terminal at the control terminal block as the source of auxiliary frequency reference. | | | | | | | | | | | | | | | | | | | | | | | | | |
| BAS-02 Aux Calc Type | Set the auxiliary reference gain with BAS-03 (Aux Ref Gain) to configure the auxiliary reference and set the percentage to be reflected when calculating the main reference. Note that items 4–7 below may result in either plus (+) or minus (-) references (forward or reverse operation) even when unipolar analog inputs are used. | | | | | | | | | | | | | | | | | | | | | | | | | | |
| | <table border="1"> <thead> <tr> <th>Configuration</th> <th>Formula for frequency reference</th> </tr> </thead> <tbody> <tr> <td>0</td> <td>$M+(G \cdot A)$</td> <td>Main reference $+(BAS-03 \times BAS-01 \times IN-01)$</td> </tr> <tr> <td>1</td> <td>$M \cdot (G \cdot A)$</td> <td>Main reference $\times (BAS-03 \times BAS-01)$</td> </tr> <tr> <td>2</td> <td>$M / (G \cdot A)$</td> <td>Main reference $/ (BAS-03 \times BAS-01)$</td> </tr> <tr> <td>3</td> <td>$M + \{M \cdot (G \cdot A)\}$</td> <td>Main reference $+ \{ \text{Main reference} \times (BAS-03 \times BAS-01) \}$</td> </tr> <tr> <td>4</td> <td>$M + G \cdot 2 \cdot (A - 50)$</td> <td>Main reference $+ BAS-03 \times 2 \times (BAS-01 - 50) \times IN-01$</td> </tr> <tr> <td>5</td> <td>$M \cdot \{G \cdot 2 \cdot (A - 50)\}$</td> <td>Main reference $\times \{ BAS-03 \times 2 \times (BAS-01 - 50) \}$</td> </tr> <tr> <td>6</td> <td>$M / \{G \cdot 2 \cdot (A - 50)\}$</td> <td>Main reference $/ \{ BAS-03 \times 2 \times (BAS-01 - 50) \}$</td> </tr> <tr> <td>7</td> <td>$M + M \cdot G \cdot 2 \cdot (A - 50)$</td> <td>Main reference $+ \text{Main reference} \times BAS-03 \times 2 \times (BAS-01 - 50)$</td> </tr> </tbody> </table> | Configuration | Formula for frequency reference | 0 | $M+(G \cdot A)$ | Main reference $+(BAS-03 \times BAS-01 \times IN-01)$ | 1 | $M \cdot (G \cdot A)$ | Main reference $\times (BAS-03 \times BAS-01)$ | 2 | $M / (G \cdot A)$ | Main reference $ / (BAS-03 \times BAS-01)$ | 3 | $M + \{M \cdot (G \cdot A)\}$ | Main reference $+ \{ \text{Main reference} \times (BAS-03 \times BAS-01) \}$ | 4 | $M + G \cdot 2 \cdot (A - 50)$ | Main reference $+ BAS-03 \times 2 \times (BAS-01 - 50) \times IN-01$ | 5 | $M \cdot \{G \cdot 2 \cdot (A - 50)\}$ | Main reference $\times \{ BAS-03 \times 2 \times (BAS-01 - 50) \}$ | 6 | $M / \{G \cdot 2 \cdot (A - 50)\}$ | Main reference $ / \{ BAS-03 \times 2 \times (BAS-01 - 50) \}$ | 7 | $M + M \cdot G \cdot 2 \cdot (A - 50)$ | Main reference $+ \text{Main reference} \times BAS-03 \times 2 \times (BAS-01 - 50)$ |
| | Configuration | Formula for frequency reference | | | | | | | | | | | | | | | | | | | | | | | | | |
| | 0 | $M+(G \cdot A)$ | Main reference $+(BAS-03 \times BAS-01 \times IN-01)$ | | | | | | | | | | | | | | | | | | | | | | | | |
| | 1 | $M \cdot (G \cdot A)$ | Main reference $\times (BAS-03 \times BAS-01)$ | | | | | | | | | | | | | | | | | | | | | | | | |
| | 2 | $M / (G \cdot A)$ | Main reference $ / (BAS-03 \times BAS-01)$ | | | | | | | | | | | | | | | | | | | | | | | | |
| | 3 | $M + \{M \cdot (G \cdot A)\}$ | Main reference $+ \{ \text{Main reference} \times (BAS-03 \times BAS-01) \}$ | | | | | | | | | | | | | | | | | | | | | | | | |
| | 4 | $M + G \cdot 2 \cdot (A - 50)$ | Main reference $+ BAS-03 \times 2 \times (BAS-01 - 50) \times IN-01$ | | | | | | | | | | | | | | | | | | | | | | | | |
| | 5 | $M \cdot \{G \cdot 2 \cdot (A - 50)\}$ | Main reference $\times \{ BAS-03 \times 2 \times (BAS-01 - 50) \}$ | | | | | | | | | | | | | | | | | | | | | | | | |
| | 6 | $M / \{G \cdot 2 \cdot (A - 50)\}$ | Main reference $ / \{ BAS-03 \times 2 \times (BAS-01 - 50) \}$ | | | | | | | | | | | | | | | | | | | | | | | | |
| 7 | $M + M \cdot G \cdot 2 \cdot (A - 50)$ | Main reference $+ \text{Main reference} \times BAS-03 \times 2 \times (BAS-01 - 50)$ | | | | | | | | | | | | | | | | | | | | | | | | | |
| M: Main frequency reference (Hz or rpm) | | | | | | | | | | | | | | | | | | | | | | | | | | | |
| G: Auxiliary reference gain (%) | | | | | | | | | | | | | | | | | | | | | | | | | | | |
| A: Auxiliary frequency reference (Hz or rpm) or gain (%) | | | | | | | | | | | | | | | | | | | | | | | | | | | |
| BAS-03 Aux Ref Gain | Adjust the size of the input (BAS-01 Aux Ref Src) configured for auxiliary frequency. | | | | | | | | | | | | | | | | | | | | | | | | | | |
| IN-65–71 Px Define | Set one of the multi-function input terminals to 36 (dis Aux Ref) and turn it on to disable the auxiliary frequency reference. The inverter will operate using the main frequency reference only. | | | | | | | | | | | | | | | | | | | | | | | | | | |

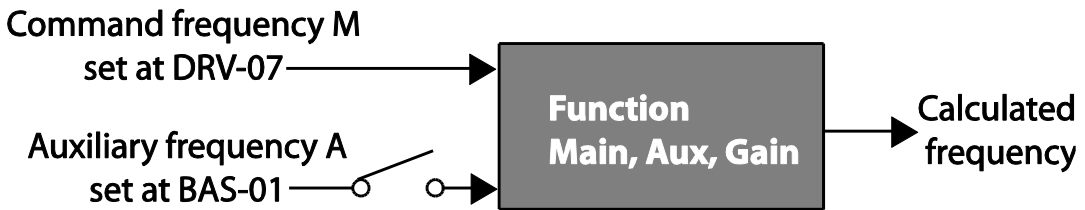

Auxiliary Reference Operation Ex #1

Keypad Frequency Setting is Main Frequency and V1 Analog Voltage is Auxiliary Frequency

- Main frequency: Keypad (operation frequency 30 Hz)
- Maximum frequency setting (DRV-20): 400 Hz
- Auxiliary frequency setting (BAS-01): V1[Display by percentage(%) or auxiliary frequency (Hz) depending on the operation setting condition]
- Auxiliary reference gain setting (BAS-03): 50%
- IN-01-32: Factory default

Example: an input voltage of 6 V is supplied to V1, and the frequency corresponding to 10 V is 60 Hz. The table below shows the auxiliary frequency A as 36 Hz[=60 Hz X (6 V/10 V)] or 60%[= 100% X (6 V/10 V)].

| Setting * | Calculating final command frequency** |
|-----------------------------------|---|
| 0 M[Hz]+(G[%]*A[Hz]) | 30 Hz(M)+(50%(G)x36 Hz(A))=48 Hz |
| 1 M[Hz]*(G[%]*A[%]) | 30 Hz(M)x(50%(G)x60%(A))=9 Hz |
| 2 M[Hz]/(G[%]*A[%]) | 30 Hz(M)/(50%(G)x60%(A))=100 Hz |
| 3 M[Hz]+(M[Hz]*(G[%]*A[%])) | 30 Hz(M)+{30[Hz]x(50%(G)x60%(A))}=39 Hz |
| 4 M[Hz]+G[%]*2*(A[%]-50[%])[Hz] | 30 Hz(M)+50%(G)x2x(60%(A)-50%)x60 Hz=36 Hz |
| 5 M[Hz]*{G[%]*2*(A[%]-50[%])} | 30 Hz(M)x{50%(G)x2x(60%(A)-50%)}=3 Hz |
| 6 M[Hz]/{G[%]*2*(A[%]-50[%])} | 30 Hz(M)/{50%(G)x2x(60%-50%)}=300 Hz |
| 7 M[Hz]+M[Hz]*G[%]*2*(A[%]-50[%]) | 30 Hz(M)+30 Hz(M)x50%(G)x2x(60%(A)-50%)=33 Hz |

* M: main frequency reference (Hz or rpm)/G: auxiliary reference gain (%)/A: auxiliary frequency reference (Hz or rpm) or gain (%).

**If the frequency setting is changed to rpm, it is converted to rpm instead of Hz.

Auxiliary Reference Operation Ex #2

Keypad Frequency Setting is Main Frequency and I2 Analog Voltage is Auxiliary Frequency

- Main frequency: Keypad (Operation frequency 30 Hz)
- Maximum frequency setting (BAS-20): 400 Hz
- Auxiliary frequency setting (BAS-01): I2 [Display by percentage (%) or auxiliary frequency (Hz) depending on the operation setting condition]
- Auxiliary reference gain setting (BAS-03): 50%
- IN-01–32: Factory default

Example: an input current of 10.4 mA is applied to I2, with the frequency corresponding to 20 mA of 60 Hz. The table below shows auxiliary frequency as 24 Hz(=60[Hz] X {(10.4[mA]-4[mA])/(20[mA] - 4[mA])}) or 40%(=100[%] X {(10.4[mA] - 4[mA])/(20[mA] - 4[mA])}).

| Setting* | Calculating final command frequency** |
|-----------------------------------|---|
| 0 M[Hz]+(G[%]*A[Hz]) | 30Hz(M)+(50%(G)x24Hz(A))=42Hz |
| 1 M[Hz]*(G[%]*A[%]) | 30Hz(M)x(50%(G)x40%(A))=6Hz |
| 2 M[Hz]/(G[%]*A[%]) | 30Hz(M)/(50%(G)x40%(A))=150Hz |
| 3 M[Hz]+{M[Hz]*(G[%]*A[%])} | 30Hz(M)+{30[Hz]x(50%(G)x40%(A))}=36Hz |
| 4 M[Hz]+G[%]*2*(A[%]-50[%])[Hz] | 30Hz(M)+50%(G)x2x(40%(A)-50%)x60Hz=24Hz |
| 5 M[Hz]*{G[%]*2*(A[%]-50[%])} | 30Hz(M)x{50%(G)x2x(40%(A)-50%)} = -3Hz(Reverse) |
| 6 M[Hz]/{G[%]*2*(A[%]-50[%])} | 30Hz(M)/{50%(G)x2x(60%-40%)} = -300Hz(Reverse) |
| 7 M[Hz]+M[Hz]*G[%]*2*(A[%]-50[%]) | 30Hz(M)+30Hz(M)x50%(G)x2x(40%(A)-50%)=27Hz |

* M: main frequency reference (Hz or rpm)/G: auxiliary reference gain (%)/A: auxiliary frequency reference Hz or rpm) or gain (%).

**If the frequency setting is changed to rpm, it is converted to rpm instead of Hz.

Auxiliary Reference Operation Ex #3

V1 is Main Frequency and I2 is Auxiliary Frequency

- Main frequency: V1 (frequency command setting to 5 V and is set to 30 Hz)
- Maximum frequency setting (DRV-20): 400 Hz
- Auxiliary frequency (BAS-01): I2[Display by percentage (%) or auxiliary frequency (Hz) depending on the operation setting condition]
- Auxiliary reference gain (BAS-03): 50%
- IN-01–32: Factory default

Example: An input current of 10.4 mA is applied to I2, with the frequency corresponding to 20 mA of 60 Hz. The table below shows auxiliary frequency A as 24 Hz ($=60[\text{Hz}] \times \{(10.4[\text{mA}] - 4[\text{mA}]) / (20[\text{mA}] - 4[\text{mA}])\}$) or 40% ($=100[\%] \times \{(10.4[\text{mA}] - 4[\text{mA}]) / (20[\text{mA}] - 4[\text{mA}])\}$).

| Setting* | Calculating final command frequency** |
|-----------------------------------|--|
| 0 M[Hz]+(G[%]*A[Hz]) | 30 Hz(M)+(50%(G)x24 Hz(A))=42 Hz |
| 1 M[Hz]*(G[%]*A[%]) | 30 Hz(M)x(50%(G)x40%(A))=6 Hz |
| 2 M[Hz]/(G[%]*A[%]) | 30 Hz(M)/(50%(G)x40%(A))=150 Hz |
| 3 M[Hz]+{M[Hz]*(G[%]*A[%])} | 30 Hz(M)+{30[Hz]x(50%(G)x40%(A))}=36 Hz |
| 4 M[Hz]+G[%]*2*(A[%]-50[%])[Hz] | 30 Hz(M)+50%(G)x2x(40%(A)-50%)x60 Hz=24 Hz |
| 5 M[Hz]*{G[%]*2*(A[%]-50[%])} | 30 Hz(M)x{50%(G)x2x(40%(A)-50%)=-3 Hz(Reverse) |
| 6 M[Hz]/{G[%]*2*(A[%]-50[%])} | 30 Hz(M)/{50%(G)x2x(60%-40%)=-300 Hz(Reverse) |
| 7 M[Hz]+M[Hz]*G[%]*2*(A[%]-50[%]) | 30 Hz(M)+30 Hz(M)x50%(G)x2x(40%(A)-50%)=27 Hz |

* M: main frequency reference (Hz or rpm)/G: auxiliary reference gain (%)/A: auxiliary frequency reference (Hz or rpm) or gain (%).

**If the frequency setting is changed to rpm, it is converted to rpm instead of Hz.

Note

When the maximum frequency value is high, output frequency deviation may result due to analog input variation and deviations in the calculations.

5.2 Jog Operation

The jog operation allows for a temporary control of the inverter. You can enter a jog operation command using the multi-function terminals or by using the [ESC] key on the keypad.

The jog operation is the second highest priority operation, after the dwell operation. If a jog operation is requested while operating the multi-step, up-down, or 3-wire operation modes, the jog operation overrides all other operation modes.

5.2.1 Jog Operation 1-Forward Jog by Multi-function Terminal

The jog operation is available in either forward or reverse direction, using the keypad or multi-function terminal inputs. The table below lists parameter setting for a forward jog operation using the multi-function terminal inputs.

| Group | Code | LCD Display | LCD Display | Parameter Setting | Setting Range | Unit |
|-------|-------|---------------------------------|-----------------------|-------------------|--------------------------|------|
| DRV | 11 | Jog frequency | JOG Frequency | 10.00 | 0.00, Low Freq–High Freq | Hz |
| | 12 | Jog operation acceleration time | JOG Acc Time | 20.00 | 0.00–600.00 | sec |
| | 13 | Jog operation deceleration time | JOG Dec Time | 30.00 | 0.00–600.00 | sec |
| IN | 65–71 | Px terminal configuration | Px Define (Px: P1–P7) | 6 JOG | 0-55 | - |

Forward Jog Description Details

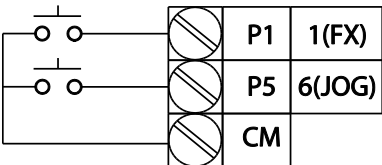
| Code | Description |
|----------------------|--|
| IN-65–71 Px Define | <p>Select the jog frequency from P1- P7 and then select 6. Jog from IN-65-71.</p>  <p>[Terminal settings for jog operation]</p> |
| DRV-11 JOG Frequency | Set the operation frequency. |

| Code | Description |
|---------------------|-----------------------------|
| DRV-12 JOG Acc Time | Set the acceleration speed. |
| DRV-13 JOG Dec Time | Set the deceleration speed. |

If a signal is entered at the jog terminal while an FX operation command is on, the operation frequency changes to the jog frequency and the jog operation begins.

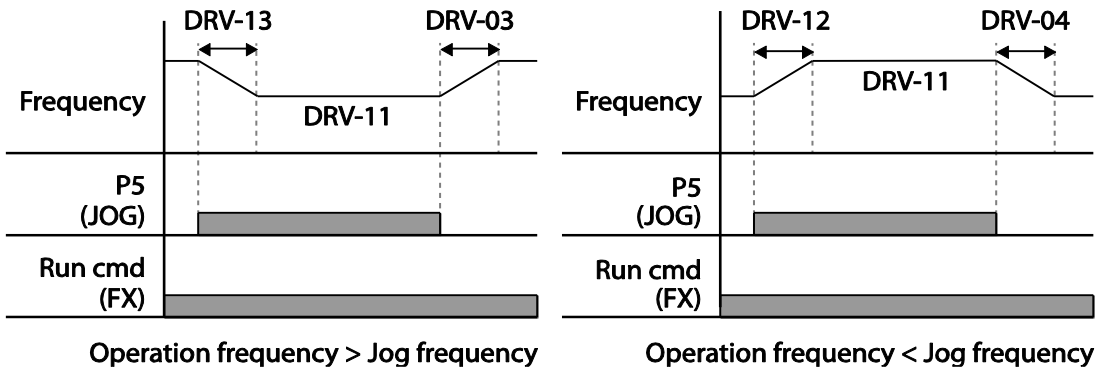

5.2.2 Jog Operation 2-Forward/Reverse Jog by Multi-function Terminal

For jog operation 1, an operation command must be entered to start operation, but while using jog operation 2, a terminal that is set for a forward or reverse jog also starts an operation. The priorities for frequency, Acc/Dec time and terminal block input during operation in relation to other operating modes (Dwell, 3-wire, up/down, etc.) are identical to jog operation 1. If a different operation command is entered during a jog operation, it is ignored and the operation maintains the jog frequency.

| Group | Code | Name | LCD Display | Parameter setting | Setting Range | Unit | |
|-------|-------|---------------------------------|-----------------------|-------------------|--------------------------|------|---|
| DRV | 11 | Jog frequency | JOG Frequency | 10.00 | 0.00, Low Freq–High Freq | Hz | |
| | 12 | Jog operation acceleration time | JOG Acc Time | 20.00 | 0.00–600.00 | sec | |
| | 13 | Operation deceleration time | JOG Dec Time | 30.00 | 0.00–600.00 | sec | |
| IN | 65–71 | Px terminal configuration | Px Define (Px: P1–P7) | 38 | FWD JOG | 0-55 | - |
| | | | | 39 | REV JOG | | |

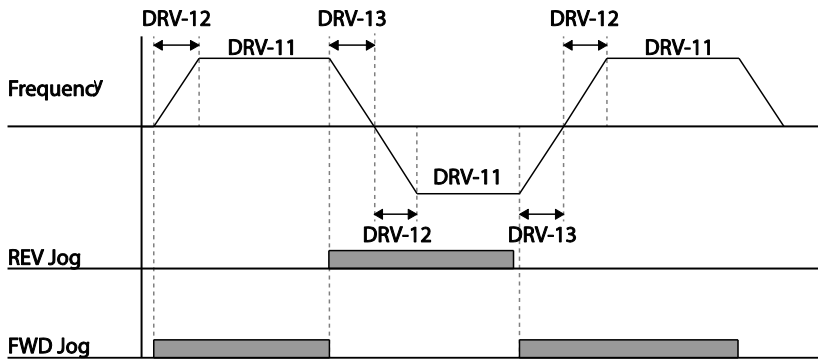

5.3 Up-down Operation

The Acc/Dec time can be controlled through input at the multi-function terminal block. Similar to a flowmeter, the up-down operation can be applied easily to a system that uses the upper-lower limit switch signals for Acc/Dec commands.

| Group | Code | Name | LCD Display | Parameter Setting | | Setting Range | Unit |
|-------|-------|----------------------------------|----------------------|-------------------|-----------|---------------|------|
| ADV | 65 | Up-down operation frequency save | U/D Save Mode | 1 | Yes | 0-1 | - |
| IN | 65-71 | Px terminal configuration | Px Define(Px: P1-P7) | 19 | Up | 0-55 | - |
| | | | | 20 | Down | | |
| | | | | 22 | U/D Clear | | |

Up-down Operation Setting Details

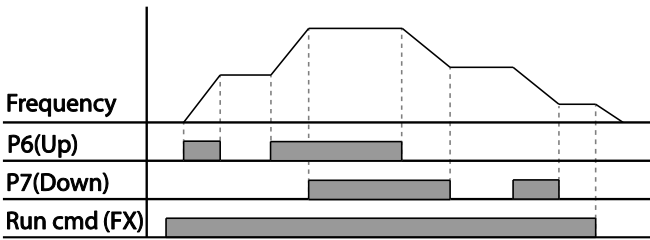
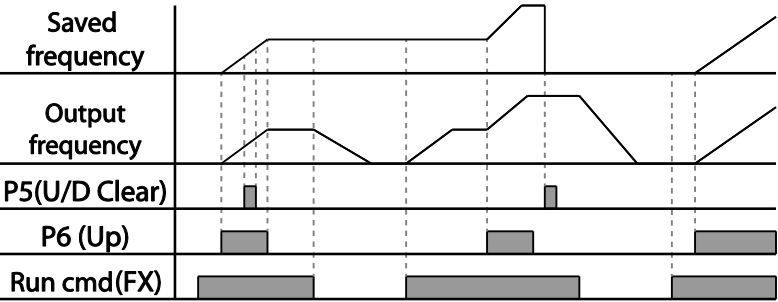
| Code | Description |
|-----------------------------|--|
| <p>IN-65-71 Px Define</p> | <p>Select two terminals for up-down operation and set them to '19 (Up)' and '20 (Down)', respectively. With the operation command input, acceleration begins when the Up terminal signal is on. Acceleration stops and constant speed operation begins when the signal is off.</p> <p>During operation, deceleration begins when the Down signal is on. Deceleration stops and constant speed operation begins when both Up and Down signals are entered at the same time.</p>  <p>The diagram shows a frequency profile with three phases: acceleration, constant speed, and deceleration. P6(Up) is active during acceleration and the first constant speed phase. P7(Down) is active during deceleration and the second constant speed phase. Run cmd (FX) is active throughout the entire operation.</p> |
| <p>ADV-65 U/D Save Mode</p> | <p>During a constant speed operation, the operating frequency is saved automatically in the following conditions: the operation command (Fx or Rx) is off, a fault trip occurs, or the power is off.</p> <p>When the operation command is turned on again, or when the inverter regains the power source or resumes to a normal operation from a fault trip, it resumes operation at the saved frequency. To delete the saved frequency, use the multi-function terminal block. Set one of the multi-function terminals to 22 (U/D Clear) and apply signals to it during constant speed operation. The saved frequency and the up-down operation configuration will be deleted.</p>  <p>The diagram shows a frequency profile with three constant speed segments. Saved frequency is shown as a horizontal line that jumps to the current operating frequency during each constant speed segment. P5(U/D Clear) pulses occur during the constant speed segments. P6 (Up) is active during acceleration and the first constant speed segment. Run cmd (FX) is active throughout the entire operation.</p> |

5.4 3- Wire Operation

The 3-wire operation latches the signal input (the signal stays on after the button is released), and is used when operating the inverter with a push button.

| Group | Code | Name | LCD Display | Parameter Setting | | Setting Range | Unit |
|-------|-------|---------------------------|----------------------|-------------------|-----------|---------------|------|
| DRV | 07 | Command source | Cmd Source* | 1 | Fx/Rx - 1 | 0-11 | - |
| IN | 65-71 | Px terminal configuration | Px Define(Px: P1-P7) | 16 | 3-Wire | 0-55 | - |

To enable the 3-wire operation, the following circuit sequence is necessary. The minimum input time (t) for 3-wire operation is 2 ms, and the operation stops when both forward and reverse operation commands are entered at the same time.

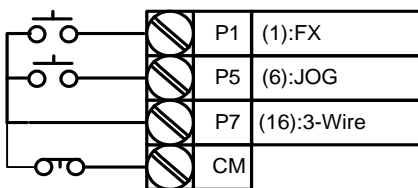

[Terminal connections for 3-wire operation]

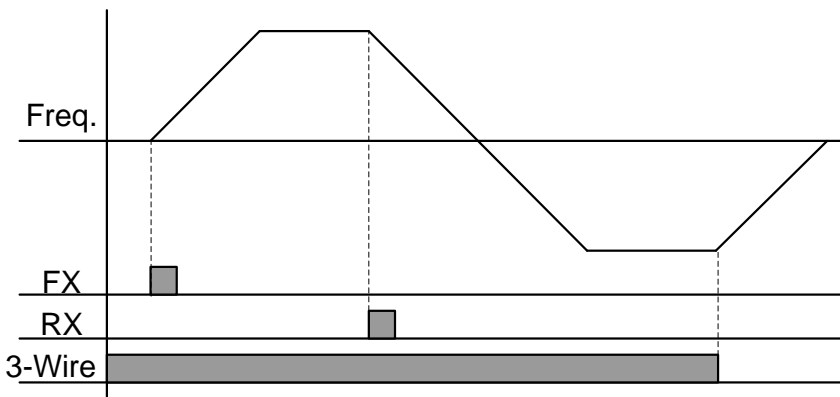

[3- wire operation]

5.5 Safe Operation Mode

When the multi-function terminals are configured to operate in safe mode, operation commands can be entered in the Safe operation mode only. Safe operation mode is used to safely and carefully control the inverter through the multi-function terminals.

| Group | Code | Name | LCD Display | Parameter Setting | | Setting Range | Unit |
|-------|-------|----------------------------------|----------------------|-------------------|--------------|---------------|------|
| ADV | 70 | Safe operation selection | Run En Mode | 1 | DI Dependent | 0-1 | - |
| | 71 | Safe operation stop mode | Run Dis Stop | 0 | Free-Run | 0-2 | - |
| | 72 | Safe operation deceleration time | Q-Stop Time | 5.0 | | 0.0-600.0 | sec |
| IN | 65-71 | Px terminal configuration | Px Define(Px: P1-P7) | 15 | RUN Enable | 0-55 | - |

Safe Operation Mode Setting Details

| Code | Description | | | | | | |
|---|--|---------------|----------|----------|---------------|--------|--------------|
| IN-65-71 Px Define | From the multi-function terminals, select a terminal to operate in safe operation mode and set it to '15 (RUN Enable)'. | | | | | | |
| ADV-70 Run En Mode | <table border="1"> <thead> <tr> <th>Setting</th> <th>Function</th> </tr> </thead> <tbody> <tr> <td>0</td> <td>Always Enable</td> </tr> <tr> <td>1</td> <td>DI Dependent</td> </tr> </tbody> </table> | Setting | Function | 0 | Always Enable | 1 | DI Dependent |
| | Setting | Function | | | | | |
| | 0 | Always Enable | | | | | |
| 1 | DI Dependent | | | | | | |
| <table border="1"> <thead> <tr> <th>Setting</th> <th>Function</th> </tr> </thead> <tbody> <tr> <td>1</td> <td>Free-Run</td> </tr> <tr> <td>2</td> <td>Q-Stop</td> </tr> </tbody> </table> | Setting | Function | 1 | Free-Run | 2 | Q-Stop | |
| Setting | Function | | | | | | |
| 1 | Free-Run | | | | | | |
| 2 | Q-Stop | | | | | | |
| ADV-71 Run Dis Stop | <p>Set the operation of the inverter when the multi-function input terminal in safe operation mode is off.</p> <p>When the safety operation mode terminal signal is given, the inverter decelerates based on the settings at the Q-Stop time. The inverter decelerates and stops based on the deceleration time (Dec Time) settings if the run command is off.</p> | | | | | | |

| Code | Description | | |
|--------------------|--|-----------------|--|
| | | terminal is on. | |
| | 3 | Q-Stop Resume | The inverter decelerates to the deceleration time (Q-Stop Time) in safe operation mode. It stops after deceleration. Then if the multi-function terminal is on, the operation resumes as soon as the operation command is entered again. |
| ADV-72 Q-Stop Time | Sets the deceleration time when ADV-71 Run Dis Stop is set to '1 (Q-Stop)' or '2 (Q-Stop Resume)'. | | |

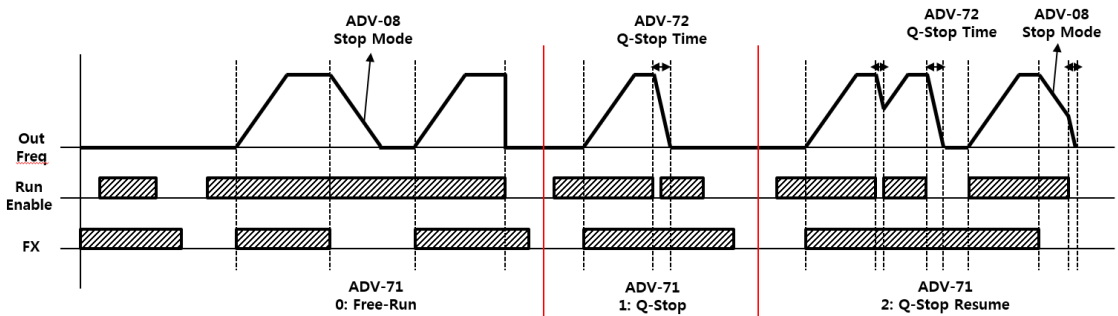

5.6 Dwell Operation

The dwell operation is used to maintain torque during the application and release of the mechanical brakes on lift-type loads. Inverter dwell operation is based on the Acc/Dec dwell frequency and the dwell time set by the user. The following points also affect dwell operation.

- **Acceleration Dwell Operation:** When an operation command runs, acceleration continues until the acceleration dwell frequency and constant speed is reached within the acceleration dwell operation time (Acc Dwell Time). After the Acc Dwell Time has passed, acceleration is carried out based on the acceleration time and the operation speed that was originally set.
- **Deceleration Dwell Operation:** When a stop command is run, deceleration continues until the deceleration dwell frequency and constant speed are reached within the deceleration dwell operation time (Dec Dwell Freq). After the set time has passed, deceleration is carried out based on the deceleration time that was originally set, then the operation stops.

| Group | Code | Name | LCD Display | Parameter Setting | Setting Range | Unit |
|-------|------|-------------------------------------|----------------|-------------------|-------------------------------------|------|
| ADV | 20 | Dwell frequency during acceleration | Acc Dwell Freq | 5.00 | Start frequency – Maximum frequency | Hz |
| | 21 | Operation time during acceleration | Acc Dwell Time | 0.0 | 0.0–10.0 | sec |
| | 22 | Dwell frequency during deceleration | Dec Dwell Freq | 5.00 | Start frequency – Maximum frequency | Hz |
| | 23 | Operation time during deceleration | Dec Dwell Time | 0.0 | 0.0– 60.0 | sec |

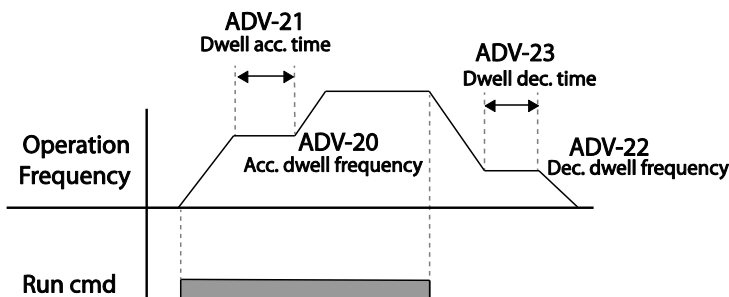

Note

Dwell operation does not work when:

- Dwell operation time is set to 0 sec or dwell frequency is set to 0 Hz.

- Re-acceleration is attempted from stop or during deceleration, as only the first acceleration dwell operation command is valid.

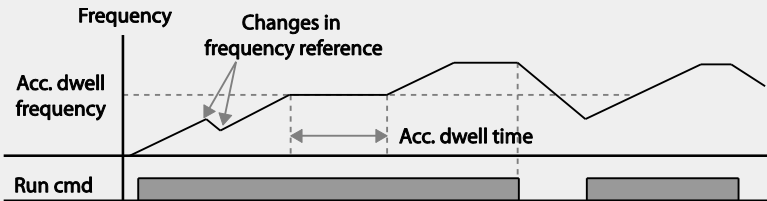

[Acceleration dwell operation]

- Although deceleration dwell operation is carried out whenever stop commands are entered and the deceleration dwell frequency is passed through, it does not work during a deceleration by simple frequency change (which is not a deceleration due to a stop operation), or during external brake control applications.

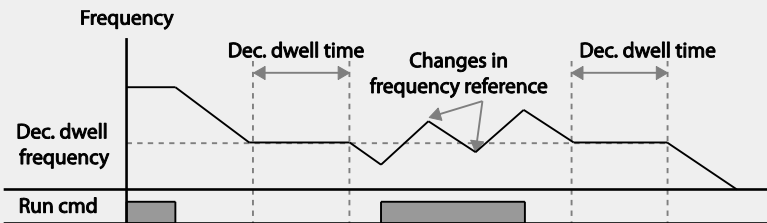

[Deceleration dwell operation]

5.7 Slip Compensation Operation

Slip refers to the variation between the setting frequency (synchronous speed) and motor rotation speed. As the load increases there can be variations between the setting frequency and motor rotation speed. Slip compensation is used for loads that require compensation of these speed variations.

| Group | Code | Name | LCD Display | Parameter Setting | | Setting Range | Unit |
|-------|------|-----------------------|----------------|--------------------|-------------|---------------|------|
| DRV | 09 | Control Mode | Control Mode | 1 | Slip Compen | - | - |
| | 14 | Motor Capacity | Motor Capacity | 2 | 5.5 kW | 0–20 | - |
| BAS | 11 | Number of motor poles | Pole Number | 4 | | 2–48 | - |
| | 12 | Rated slip speed | Rated Slip | 40 (5.5 kW based) | | 0–3000 | Rp m |
| | 13 | Rated motor current | Rated Curr | 3.6 (5.5 kW based) | | 1.0–1000.0 | A |
| | 14 | Motor no-load current | Noload Curr | 1.6 (5.5 kW based) | | 0.5–1000.0 | A |
| | 16 | Motor efficiency | Efficiency | 72 (5.5 kW based) | | 70–100 | % |

Slip Compensation Operation Setting Details

| Code | Description |
|-----------------------|--|
| DRV-09 Control Mode | Set DRV-09 to '2 (Slip Compen)' to carry out the slip compensation operation. |
| DRV-14 Motor Capacity | Set the capacity of the motor connected to the inverter. |
| BAS-11 Pole Number | Enter the number of poles from the motor rating plate. |
| BAS-12 Rated Slip | Enter the number of rated rotations from the motor rating plate. $f_s = f_r - \frac{Rpm \times P}{120}$ f_s = Rated slip frequency f_r = Rated frequency Rpm = Number of the rated motor rotations P = Number of motor poles |
| BAS-13 Rated Curr | Enter the rated current from the motor rating plate. |

| Code | Description |
|--------------------|---|
| BAS-14 Noload Curr | Enter the measured current when the load on the motor axis is removed and when the motor is operated at the rated frequency. If no-load current is difficult to measure, enter a current equivalent to 30-50% of the rated motor current. |
| BAS-16 Efficiency | Enter the efficiency from the motor rating place. |

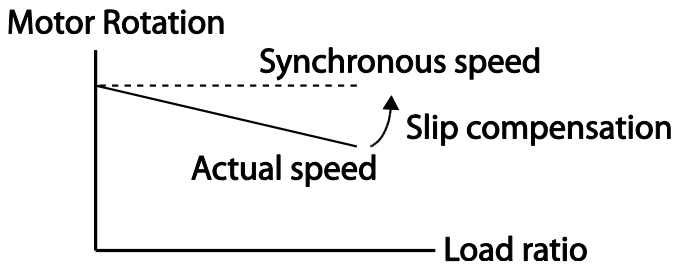

5.8 PID Control

PID control is one of the most common auto-control methods. It uses a combination of proportional, integral, and differential (PID) controls that provide more effective control for automated systems. The functions of PID control that can be applied to the inverter operation are as follows:

| Purpose | Function |
|---------------------|---|
| Speed Control | Controls speed by monitoring the current speed levels of the equipment or machinery being controlled. Control maintains consistent speed or operates at the target speed. |
| Pressure Control | Controls pressure by monitoring the current pressure levels of the equipment or machinery being controlled. Control maintains consistent pressure or operates at the target pressure. |
| Flow Control | Controls flow by monitoring the current amount of flow in the equipment or machinery being controlled. Control maintains consistent flow or operates at a target flow. |
| Temperature Control | Controls temperature by monitoring the current temperature levels of the equipment or machinery to be controlled. Control maintains a consistent temperature or operates at a target temperature. |

5.8.1 PID Basic Operation

PID operates by controlling the output frequency of the inverter, through automated system process control to maintain speed, pressure, flow, temperature or tension.

| Group | Code | Name | LCD Display | Parameter Setting | | Setting Range | Unit |
|-------|------|--|-----------------|-------------------|---------|-------------------|------|
| PID | 01 | PID Options | PID Sel | 0 | No | 0–1 | - |
| | 03 | PID output monitor | PID Output | - | | - | - |
| | 04 | PID reference monitor | PID Ref Value | - | | - | - |
| | 05 | PID feedback monitor | PID Fdb Value | - | | - | - |
| | 06 | PID Error Monitor | PID Err Value | | | | |
| | 10 | PID reference source | PID Ref1 Source | 0 | Keypad | 0–11 | - |
| | 11 | PID reference setting | PID Ref Set | Unit Default | | Unit Min–Unit Max | Unit |
| | 12 | PID reference 1 auxiliary source selection | PID Ref1AuxSrc | 0 | None | 0–13 | - |
| | 13 | PID reference 1 auxiliary mode selection | PID Ref1AuxMod | 0 | M+(G*A) | 0–13 | - |
| | 14 | PID reference auxiliary gain | PID Ref 1 Aux G | 0.0 | | -200.0–200.0 | Unit |
| | 15 | PID reference 2 auxiliary source selection | PID Ref 2 Src | 0 | Keypad | 0–11 | - |
| | 16 | PID reference 2 keypad setting | PID Ref 2 Set | Unit Default | | Unit Min–Unit Max | Unit |
| | 17 | PID reference 2 auxiliary source selection | PID Ref2AuxSrc | 0 | None | 0–13 | - |
| | 18 | PID reference 2 auxiliary mode selection | PID Ref2AuxMod | 0 | M+(G*A) | 0–12 | - |

Learning Advanced Features

| Group | Code | Name | LCD Display | Parameter Setting | | Setting Range | Unit |
|-------|------|---|----------------|-------------------|---------|----------------------|------|
| | 19 | PID reference 2 auxiliary gain | PID Ref2 Aux G | 0.0 | | -200.0–200.0 | Unit |
| | 20 | PID feedback source selection | PID Fdb Src | 0 | V1 | 0–9 | |
| | 21 | PID feedback auxiliary source selection | PID Fdb AuxSrc | 0 | None | 0–11 | |
| | 22 | PID feedback auxiliary mode selection | PID Fdb AuxMod | 0 | M+(G+A) | 0–13 | |
| | 23 | PID feedback auxiliary gain | PID Fdb Aux G | 0.0 | | -200.0–200.0 | Unit |
| | 24 | PID feedback band | PID Fdb Band | 0 | | 0–Unit Band | Unit |
| | 25 | PID proportional gain 1 | PID P-Gain 1 | 50.0 | | 0.0–300.00 | Unit |
| | 26 | PID integral time 1 | PID I-Time 1 | 10.0 | | 0.0–200.0 | sec |
| | 27 | PID differential time 1 | PID D-Time 1 | 0.00 | | 0–1.00 | sec |
| | 28 | PID feed forward gain | PID FF-Gain | 0.0 | | 0.0–1000.0 | Unit |
| | 29 | PID output filter | PID Out LPF | 0.00 | | 0–10.00 | sec |
| | 30 | PID output upper limit | PID Limit Hi | 100.00 | | PID Limit Lo–100.00 | Unit |
| | 31 | PID output lower limit | PID Limit Lo | 0.00 | | -100.00–PID Limit Hi | Unit |
| | 32 | PID proportional gain 2 | PID P-Gain 2 | 5.0 | | 0.0–300.00 | Unit |
| | 33 | PID integral time 2 | PID I-Time 2 | 10.0 | | 0.0–200.0 | sec |
| | 34 | PID differential time 2 | PID D-Time 2 | 0.00 | | 0–1.00 | sec |
| | 35 | PID output mode setting | PID Out Mode | 4 | | PID or Main | 0–4 |
| | 36 | PID output | PID Out Inv | 0 | | No | 0–1 |

| Group | Code | Name | LCD Display | Parameter Setting | | Setting Range | Unit |
|-------|-------|------------------------------------|----------------------|-------------------|------|------------------------------------|------|
| | | reverse | | | | | |
| | 37 | PID output scale | PID Out Scale | 100.0 | | 0.1–1000.0 | Unit |
| | 40 | PID multi-step reference setting 1 | PID Step Ref 1 | Unit Default | | Unit Min–Unit Max | Unit |
| | 41 | PID multi-step reference setting 2 | PID Step Ref 2 | Unit Default | | Unit Min–Unit Max | Unit |
| | 42 | PID multi-step reference setting 3 | PID Step Ref 3 | Unit Default | | Unit Min–Unit Max | Unit |
| | 43 | PID multi-step reference setting 4 | PID Step Ref 4 | Unit Default | | Unit Min–Unit Max | Unit |
| | 44 | PID multi-step reference setting 5 | PID Step Ref 5 | Unit Default | | Unit Min–Unit Max | Unit |
| | 45 | PID multi-step reference setting 6 | PID Step Ref 6 | Unit Default | | Unit Min–Unit Max | Unit |
| | 46 | PID multi-step reference setting 7 | PID Step Ref 7 | Unit Default | | Unit Min–Unit Max | Unit |
| | 50 | PID controller unit selection | PID Unit Sel | 0 | % | 0–40 | - |
| | 51 | PID control setting scale | PID Unit Scale | 2 | X 1 | 0–4 | - |
| | 52 | PID control 0% setting figure | PID Unit 0% | 0.00 | | Differ depending on PID-50 setting | |
| | 53 | PID control 100% setting figure | PID Unit 100% | 100.00 | | Differ depending on PID-50 setting | |
| IN | 65–71 | Px circuit function setting | Px Define(Px: P1–P7) | 1 | none | 0–55 | - |

Note

- Normal PID output (PID OUT) is bipolar and is limited by PID-46 (PID Limit Hi) and PID-47 (PID Limit Lo) settings. DRV-20 (MaxFreq) value equals a 100% of PID OUT.
- The following are the variables used in PID operation, and how they are calculated:
 - Unit MAX = PID Unit 100% (PID-68)
 - Unit Min = (2xPID Unit 0% (PID-67)–PID Unit 100%)
 - Unit Default = (PID Unit 100%-PID Unit 0%)/2
 - Unit Band = Unit 100%-Unit 0%
- PID control may be utilized for the following operations:
Soft fill, auxiliary PID reference compensation, MMC, flow compensation, pipe breakage detection
- During a PID operation, the PID output becomes the frequency reference. The inverter accelerates or decelerates to the frequency reference based on the Acc/Dec times.

PID Basic Operation Setting Details

| Code | Description | | |
|----------------------|--|--|---------------------------------|
| PID-01 PID Sel | Sets the code to '1 (Yes)' to select functions for the process PID. | | |
| PID-03 PID Output | Displays the existing output value of the PID controller. The unit, gain, and scale that were set in the PID group are applied on the display. | | |
| PID-04 PID Ref Value | Displays the existing reference value set for the PID controller. The unit, gain, and scale that were set in the PID group are applied on the display. | | |
| PID-05 PID Fdb Value | Displays the latest feedback value of the PID controller. The unit, gain, and scale that were set in the PID group are applied on the display. | | |
| PID-06 PID Err Value | Displays the differences between the existing reference and the feedback (error value). The unit, gain, and scale that were set in the PID group are applied on the display. | | |
| PID-10 PID Ref 1 Src | Selects the reference input for the PID control. If the V1 terminal is set to a PID feedback source (PID F/B Source), the V1 terminal cannot be set to the PID reference source (PID Ref Source). To set V1 as a reference source, change the feedback source. | | |
| | Setting | Function | |
| | 0 | Keypad | Keypad |
| | 1 | V1 | -10-10 V input voltage terminal |
| | 3 | V2 | I2 analog input terminal |
| 4 | I2 | When the analog voltage/current input terminal selection switch (SW4) at the terminal block is set to I (current), input 0-20 mA current. If it is set to V (voltage), input 0–10 V. | |

| Code | Description | | |
|-----------------------|---|--|---|
| | 5 | Int. 485 | RS-485 input terminal |
| | 7 | FieldBus | Communication command via a communication option card |
| | 8 | Pulse | TI Pulse input terminal (0-32 kHz Pulse input) |
| | 9 | E-PID Output | External PID output |
| | 10 | V3 | V3 analoge input terminal of Extension IO option When the analog voltage/current input terminal selection switch (SW2) at the terminal block is set to I3(current), input 0-20 mA current. If it is set to V3 (voltage), input 0–10 V. |
| | 11 | I3 | |
| PID-11 PID Ref Set | A reference value can be entered if the PID reference type (PID-10) is set to '0 (Keypad)'. | | |
| PID-12 PID Ref1AuxSrc | Selects the external input source to be used as the reference for a PID control. If an external input source is selected, the reference is determined using the input value at the source (set at PID-10) and the value set at PID-13 PID Ref1AuxMod. | | |
| | Setting | | Function |
| | 0 | None | Not used |
| | 1 | V1 | -10-10 V input voltage terminal |
| | 3 | V2 | I2 analog input terminal |
| | 4 | I2 | [If the analog voltage/current input terminal selection switch (SW4) at the terminal block is set to I (current), input 0-20 mA current. If it is set to V (voltage), input 0–10 V] |
| | 6 | Pulse | TI Pulse input terminal (0-32 kHz Pulse input) |
| | 7 | Int. 485 | RS-485 input terminal |
| | 8 | FieldBus | Communication command via a communication option card |
| | 10 | EPID1 Output | External PID 1 Output |
| | 11 | EPID1 Fdb Val | External PID 1 feedback value |
| | 12 | V3 | V3 analog input terminal of Extension IO option When the analog voltage/current input terminal selection switch (SW2) at the terminal block is set to I3 (current), input 0-20 mA current. If it is set to V3 (voltage), input 0–10 V. |
| | 13 | I3 | |
| | PID-13 PID Ref1 AuxMod | PID-13 (PID Ref1) provides formulas to calculate the reference 1 value. If PID-12 (PID RefAuxSrc) is set to any other value than 'None,' the final reference 1 value is calculated using the input value at the source (set at PID-10) and the input value set at PID-12). | |
| Setting | | | |

| Code | Description | | | | | | | | | | | | | | | | | | | | | | | | | | | | |
|-----------------------|---|---------|-----------------|------|---------------------------------|------|---|------|---------------------------|-----------------------|----------------------------|---|------------------------------------|--|------------------------------|-----------------------|------------------------------------|-------------------------|-----------|---|-----------|----|-------------------|----|-------------------|----|-----------|----|----------------------|
| | <table border="1"> <tr><td>0</td><td>$M+(G \cdot A)$</td></tr> <tr><td>1</td><td>$M \cdot (G \cdot A)$</td></tr> <tr><td>2</td><td>$M/(G \cdot A)$</td></tr> <tr><td>3</td><td>$M+(M \cdot (G \cdot A))$</td></tr> <tr><td>4</td><td>$M+G \cdot 2 \cdot (A-50)$</td></tr> <tr><td>5</td><td>$M \cdot (G \cdot 2 \cdot (A-50))$</td></tr> <tr><td>6</td><td>$M/(G \cdot 2 \cdot (A-50))$</td></tr> <tr><td>7</td><td>$M+M \cdot G \cdot 2 \cdot (A-50)$</td></tr> <tr><td>8</td><td>$(M-A)^2$</td></tr> <tr><td>9</td><td>M^2+A^2</td></tr> <tr><td>10</td><td>$\text{MAX}(M,A)$</td></tr> <tr><td>11</td><td>$\text{MIN}(M,A)$</td></tr> <tr><td>12</td><td>$(M+A)/2$</td></tr> <tr><td>13</td><td>Square Root($M+A$)</td></tr> </table> <p>M= Value by the source set at PID-10 G= Gain value set at PID-14 A= Value input by the source set at PID-12</p> | 0 | $M+(G \cdot A)$ | 1 | $M \cdot (G \cdot A)$ | 2 | $M/(G \cdot A)$ | 3 | $M+(M \cdot (G \cdot A))$ | 4 | $M+G \cdot 2 \cdot (A-50)$ | 5 | $M \cdot (G \cdot 2 \cdot (A-50))$ | 6 | $M/(G \cdot 2 \cdot (A-50))$ | 7 | $M+M \cdot G \cdot 2 \cdot (A-50)$ | 8 | $(M-A)^2$ | 9 | M^2+A^2 | 10 | $\text{MAX}(M,A)$ | 11 | $\text{MIN}(M,A)$ | 12 | $(M+A)/2$ | 13 | Square Root($M+A$) |
| 0 | $M+(G \cdot A)$ | | | | | | | | | | | | | | | | | | | | | | | | | | | | |
| 1 | $M \cdot (G \cdot A)$ | | | | | | | | | | | | | | | | | | | | | | | | | | | | |
| 2 | $M/(G \cdot A)$ | | | | | | | | | | | | | | | | | | | | | | | | | | | | |
| 3 | $M+(M \cdot (G \cdot A))$ | | | | | | | | | | | | | | | | | | | | | | | | | | | | |
| 4 | $M+G \cdot 2 \cdot (A-50)$ | | | | | | | | | | | | | | | | | | | | | | | | | | | | |
| 5 | $M \cdot (G \cdot 2 \cdot (A-50))$ | | | | | | | | | | | | | | | | | | | | | | | | | | | | |
| 6 | $M/(G \cdot 2 \cdot (A-50))$ | | | | | | | | | | | | | | | | | | | | | | | | | | | | |
| 7 | $M+M \cdot G \cdot 2 \cdot (A-50)$ | | | | | | | | | | | | | | | | | | | | | | | | | | | | |
| 8 | $(M-A)^2$ | | | | | | | | | | | | | | | | | | | | | | | | | | | | |
| 9 | M^2+A^2 | | | | | | | | | | | | | | | | | | | | | | | | | | | | |
| 10 | $\text{MAX}(M,A)$ | | | | | | | | | | | | | | | | | | | | | | | | | | | | |
| 11 | $\text{MIN}(M,A)$ | | | | | | | | | | | | | | | | | | | | | | | | | | | | |
| 12 | $(M+A)/2$ | | | | | | | | | | | | | | | | | | | | | | | | | | | | |
| 13 | Square Root($M+A$) | | | | | | | | | | | | | | | | | | | | | | | | | | | | |
| PID-14 PID Ref1 Aux G | Gain value for the formulas provided by PID-13. | | | | | | | | | | | | | | | | | | | | | | | | | | | | |
| PID-20 PID Fdb Src | <p>Selects feedback input for PID control. If the V1 terminal is set as the PID feedback source (PID F/B Source), the V1 terminal cannot be set as the PID reference source (PID Ref Source). To set V1 as a feedback source, change the reference source.</p> <table border="1"> <thead> <tr> <th>Setting</th> <th>Function</th> </tr> </thead> <tbody> <tr> <td>0 V1</td> <td>-10-10 V input voltage terminal</td> </tr> <tr> <td>2 V2</td> <td rowspan="2">I2 analog input terminal [If the analog voltage/current input terminal selection switch (SW4) at the terminal block is set to I (current), input 0-20 mA current. If it is set to V (voltage), input 0–10 V]</td> </tr> <tr> <td>3 I2</td> </tr> <tr> <td>4 Int. 485</td> <td>RS-485 input terminal</td> </tr> <tr> <td>5 FieldBus</td> <td>Communication command via a communication option card</td> </tr> <tr> <td>7 Pulse</td> <td>TI Pulse input terminal (0-32 kHz Pulse input)</td> </tr> <tr> <td>8 EPID1 Output</td> <td>External PID 1 output</td> </tr> <tr> <td>9 EPID1 Fdb Val</td> <td>External PID 1 feedback</td> </tr> </tbody> </table> | Setting | Function | 0 V1 | -10-10 V input voltage terminal | 2 V2 | I2 analog input terminal [If the analog voltage/current input terminal selection switch (SW4) at the terminal block is set to I (current), input 0-20 mA current. If it is set to V (voltage), input 0–10 V] | 3 I2 | 4 Int. 485 | RS-485 input terminal | 5 FieldBus | Communication command via a communication option card | 7 Pulse | TI Pulse input terminal (0-32 kHz Pulse input) | 8 EPID1 Output | External PID 1 output | 9 EPID1 Fdb Val | External PID 1 feedback | | | | | | | | | | | |
| Setting | Function | | | | | | | | | | | | | | | | | | | | | | | | | | | | |
| 0 V1 | -10-10 V input voltage terminal | | | | | | | | | | | | | | | | | | | | | | | | | | | | |
| 2 V2 | I2 analog input terminal [If the analog voltage/current input terminal selection switch (SW4) at the terminal block is set to I (current), input 0-20 mA current. If it is set to V (voltage), input 0–10 V] | | | | | | | | | | | | | | | | | | | | | | | | | | | | |
| 3 I2 | | | | | | | | | | | | | | | | | | | | | | | | | | | | | |
| 4 Int. 485 | RS-485 input terminal | | | | | | | | | | | | | | | | | | | | | | | | | | | | |
| 5 FieldBus | Communication command via a communication option card | | | | | | | | | | | | | | | | | | | | | | | | | | | | |
| 7 Pulse | TI Pulse input terminal (0-32 kHz Pulse input) | | | | | | | | | | | | | | | | | | | | | | | | | | | | |
| 8 EPID1 Output | External PID 1 output | | | | | | | | | | | | | | | | | | | | | | | | | | | | |
| 9 EPID1 Fdb Val | External PID 1 feedback | | | | | | | | | | | | | | | | | | | | | | | | | | | | |
| PID-21 PID Fdb AuxSrc | Selects the external input source to be used as the reference for a PID control. When the external input source is selected, the reference is determined using the input value at the source (set at PID-10) and the value set at PID-13 PID Ref1AuxMod. | | | | | | | | | | | | | | | | | | | | | | | | | | | | |

| Code | Description | | | | | | | | | | | | | | | | | | | | | | | | | | | | | | |
|------------------------------|---|---|--|----------|-----------|------|-----------|---|-----------|---------------------------------|---------------|----|--------------------------|---|------------------|---|------------------|-------|--|---|-----------|-----------------------|-----------|----------|---|----|--------------|-----------------------|-----------|---------------|-------------------------|
| | <table border="1"> <thead> <tr> <th data-bbox="389 282 467 314">Setting</th> <th data-bbox="467 282 614 314"></th> <th data-bbox="614 282 1237 314">Function</th> </tr> </thead> <tbody> <tr> <td data-bbox="389 314 467 347">0</td> <td data-bbox="467 314 614 347">None</td> <td data-bbox="614 314 1237 347">Not used</td> </tr> <tr> <td data-bbox="389 347 467 380">1</td> <td data-bbox="467 347 614 380">V1</td> <td data-bbox="614 347 1237 380">-10-10 V input voltage terminal</td> </tr> <tr> <td data-bbox="389 380 467 413">3</td> <td data-bbox="467 380 614 413">V2</td> <td data-bbox="614 380 1237 413">I2 analog input terminal</td> </tr> <tr> <td data-bbox="389 413 467 542">4</td> <td data-bbox="467 413 614 542">I2</td> <td data-bbox="614 413 1237 542">[When the analog voltage/current input terminal selection switch (SW4) at the terminal block is set to I (current), input 0-20 mA current. If it is set to V (voltage), input 0–10 V]</td> </tr> <tr> <td data-bbox="389 542 467 575">6</td> <td data-bbox="467 542 614 575">Pulse</td> <td data-bbox="614 542 1237 575">TI Pulse input terminal (0-32 kHz Pulse input)</td> </tr> <tr> <td data-bbox="389 575 467 608">7</td> <td data-bbox="467 575 614 608">Int. 485</td> <td data-bbox="614 575 1237 608">RS-485 input terminal</td> </tr> <tr> <td data-bbox="389 608 467 678">8</td> <td data-bbox="467 608 614 678">FieldBus</td> <td data-bbox="614 608 1237 678">Communication command via a communication option card</td> </tr> <tr> <td data-bbox="389 678 467 747">10</td> <td data-bbox="467 678 614 747">EPID1 Output</td> <td data-bbox="614 678 1237 747">External PID 1 output</td> </tr> <tr> <td data-bbox="389 747 467 817">11</td> <td data-bbox="467 747 614 817">EPID1 Fdb Val</td> <td data-bbox="614 747 1237 817">External PID 1 feedback</td> </tr> </tbody> </table> | Setting | | Function | 0 | None | Not used | 1 | V1 | -10-10 V input voltage terminal | 3 | V2 | I2 analog input terminal | 4 | I2 | [When the analog voltage/current input terminal selection switch (SW4) at the terminal block is set to I (current), input 0-20 mA current. If it is set to V (voltage), input 0–10 V] | 6 | Pulse | TI Pulse input terminal (0-32 kHz Pulse input) | 7 | Int. 485 | RS-485 input terminal | 8 | FieldBus | Communication command via a communication option card | 10 | EPID1 Output | External PID 1 output | 11 | EPID1 Fdb Val | External PID 1 feedback |
| Setting | | Function | | | | | | | | | | | | | | | | | | | | | | | | | | | | | |
| 0 | None | Not used | | | | | | | | | | | | | | | | | | | | | | | | | | | | | |
| 1 | V1 | -10-10 V input voltage terminal | | | | | | | | | | | | | | | | | | | | | | | | | | | | | |
| 3 | V2 | I2 analog input terminal | | | | | | | | | | | | | | | | | | | | | | | | | | | | | |
| 4 | I2 | [When the analog voltage/current input terminal selection switch (SW4) at the terminal block is set to I (current), input 0-20 mA current. If it is set to V (voltage), input 0–10 V] | | | | | | | | | | | | | | | | | | | | | | | | | | | | | |
| 6 | Pulse | TI Pulse input terminal (0-32 kHz Pulse input) | | | | | | | | | | | | | | | | | | | | | | | | | | | | | |
| 7 | Int. 485 | RS-485 input terminal | | | | | | | | | | | | | | | | | | | | | | | | | | | | | |
| 8 | FieldBus | Communication command via a communication option card | | | | | | | | | | | | | | | | | | | | | | | | | | | | | |
| 10 | EPID1 Output | External PID 1 output | | | | | | | | | | | | | | | | | | | | | | | | | | | | | |
| 11 | EPID1 Fdb Val | External PID 1 feedback | | | | | | | | | | | | | | | | | | | | | | | | | | | | | |
| <p>PID-22 PID FDB AuxMod</p> | <p>The PID-30 (PID FDB AuxMod) provides formulas to calculate the final feedback value. If PID-31 (PID RefAuxSrc) is set to any other value than 'None,' the final feedback is calculated using the input values at the sources (set at PID-31 and PID-32).</p> <table border="1"> <thead> <tr> <th data-bbox="389 954 467 987">Setting</th> <th data-bbox="467 954 1237 987"></th> </tr> </thead> <tbody> <tr> <td data-bbox="389 987 467 1020">0</td> <td data-bbox="467 987 1237 1020">$M+(G*A)$</td> </tr> <tr> <td data-bbox="389 1020 467 1052">1</td> <td data-bbox="467 1020 1237 1052">$M*(G*A)$</td> </tr> <tr> <td data-bbox="389 1052 467 1085">2</td> <td data-bbox="467 1052 1237 1085">$M/(G*A)$</td> </tr> <tr> <td data-bbox="389 1085 467 1118">3</td> <td data-bbox="467 1085 1237 1118">$M+(M*(G*A))$</td> </tr> <tr> <td data-bbox="389 1118 467 1151">4</td> <td data-bbox="467 1118 1237 1151">$M+G*2*(A-50)$</td> </tr> <tr> <td data-bbox="389 1151 467 1184">5</td> <td data-bbox="467 1151 1237 1184">$M*(G*2*(A-50))$</td> </tr> <tr> <td data-bbox="389 1184 467 1217">6</td> <td data-bbox="467 1184 1237 1217">$M/(G*2*(A-50))$</td> </tr> <tr> <td data-bbox="389 1217 467 1250">7</td> <td data-bbox="467 1217 1237 1250">$M+M*G*2*(A-50)$</td> </tr> <tr> <td data-bbox="389 1250 467 1282">8</td> <td data-bbox="467 1250 1237 1282">$(M-A)^2$</td> </tr> <tr> <td data-bbox="389 1282 467 1315">9</td> <td data-bbox="467 1282 1237 1315">M^2+A^2</td> </tr> <tr> <td data-bbox="389 1315 467 1348">10</td> <td data-bbox="467 1315 1237 1348">$MAX(M,A)$</td> </tr> <tr> <td data-bbox="389 1348 467 1381">11</td> <td data-bbox="467 1348 1237 1381">$MIN(M,A)$</td> </tr> <tr> <td data-bbox="389 1381 467 1414">12</td> <td data-bbox="467 1381 1237 1414">$(M+A)/2$</td> </tr> <tr> <td data-bbox="389 1414 467 1447">13</td> <td data-bbox="467 1414 1237 1447">Square Root(M+A)</td> </tr> </tbody> </table> <p>M= Value by the source set at PID-30 G= Gain value set at PID-33 A= Value by the source set at PID-31</p> | Setting | | 0 | $M+(G*A)$ | 1 | $M*(G*A)$ | 2 | $M/(G*A)$ | 3 | $M+(M*(G*A))$ | 4 | $M+G*2*(A-50)$ | 5 | $M*(G*2*(A-50))$ | 6 | $M/(G*2*(A-50))$ | 7 | $M+M*G*2*(A-50)$ | 8 | $(M-A)^2$ | 9 | M^2+A^2 | 10 | $MAX(M,A)$ | 11 | $MIN(M,A)$ | 12 | $(M+A)/2$ | 13 | Square Root(M+A) |
| Setting | | | | | | | | | | | | | | | | | | | | | | | | | | | | | | | |
| 0 | $M+(G*A)$ | | | | | | | | | | | | | | | | | | | | | | | | | | | | | | |
| 1 | $M*(G*A)$ | | | | | | | | | | | | | | | | | | | | | | | | | | | | | | |
| 2 | $M/(G*A)$ | | | | | | | | | | | | | | | | | | | | | | | | | | | | | | |
| 3 | $M+(M*(G*A))$ | | | | | | | | | | | | | | | | | | | | | | | | | | | | | | |
| 4 | $M+G*2*(A-50)$ | | | | | | | | | | | | | | | | | | | | | | | | | | | | | | |
| 5 | $M*(G*2*(A-50))$ | | | | | | | | | | | | | | | | | | | | | | | | | | | | | | |
| 6 | $M/(G*2*(A-50))$ | | | | | | | | | | | | | | | | | | | | | | | | | | | | | | |
| 7 | $M+M*G*2*(A-50)$ | | | | | | | | | | | | | | | | | | | | | | | | | | | | | | |
| 8 | $(M-A)^2$ | | | | | | | | | | | | | | | | | | | | | | | | | | | | | | |
| 9 | M^2+A^2 | | | | | | | | | | | | | | | | | | | | | | | | | | | | | | |
| 10 | $MAX(M,A)$ | | | | | | | | | | | | | | | | | | | | | | | | | | | | | | |
| 11 | $MIN(M,A)$ | | | | | | | | | | | | | | | | | | | | | | | | | | | | | | |
| 12 | $(M+A)/2$ | | | | | | | | | | | | | | | | | | | | | | | | | | | | | | |
| 13 | Square Root(M+A) | | | | | | | | | | | | | | | | | | | | | | | | | | | | | | |
| <p>PID-23 PID Fdb Aux G</p> | <p>Gain value used a formula set at PID-22.</p> | | | | | | | | | | | | | | | | | | | | | | | | | | | | | | |
| <p>PID-24 PID Fdb Band</p> | <p>Sets the maximum and minimum value by adding or subtracting the PID Fdb Band value (set at PID-24) from the reference value. When the</p> | | | | | | | | | | | | | | | | | | | | | | | | | | | | | | |

Learning Advanced Features

| Code | Description | | | | | | | | | | |
|--|--|---------|--|---|------------|---|---------------|---|---------------|---|----------------|
| | feedback value is between the maximum and minimum value, this code maintains the PID output. | | | | | | | | | | |
| PID-25 PID P-Gain1 PID-32 PID P-Gain2 | Set the output ratio for differences (errors) between the reference and feedback. If the P Gain is set to 50%, then 50% of the error is output. | | | | | | | | | | |
| PID-26 PID I- Time 1 PID-33 PID I- Time 2 | <p>Sets the time to output accumulated errors. When the error is 100%, the time taken for 100% output is set. When the integral time (PID I- Time) is set to 1 second, 100% output occurs after 1 second of the error remaining at 100%. Differences in a normal state can be reduced by PID I Time. When the multi-function terminal block is set to '24 (I-Term Clear)' and is turned on, all of the accumulated errors are deleted.</p> <p>PID output (final frequency reference) is affected by the gains set at PID-26, PID-33, and the Acc/Dec times to achieve the PID output change based on the DRV-03 and DRV-04 settings. Therefore, consider the relationship between these values when configuring the gains and the Acc/Dec times.</p> | | | | | | | | | | |
| PID-27 PID D-Time 1 PID-34 PID D-Time 2 | Sets the output volume for the rate of change in errors. If the differential time (PID D-Time) is set to 1 ms and the rate of change in errors per sec is 100%, output occurs at 1% per 10 ms. | | | | | | | | | | |
| PID-28 PID FF-Gain | Sets the ratio that adds the target to the PID output. Adjusting this value leads to a faster response. | | | | | | | | | | |
| PID-29 PID Out LPF | Used when the PID controller output changes too quickly or the entire system is unstable, due to severe oscillation. In general, a lower value (default value=0) is used to speed up response time, but in some cases a higher value increases stability. The higher the value, the more stable the PID controller output is, but the slower the response time. | | | | | | | | | | |
| PID-30 PID Limit Hi, PID-31 PID Limit Lo | Limit the output of the controller. | | | | | | | | | | |
| PID-35 PID Out Mode | <p>Selects one of the PID output modes to modify the PID output. Modifications can be made by adding input values and the main operation frequency of the PID output to the final PID output value. The following table lists the 5 modes that are available.</p> <table border="1"> <thead> <tr> <th>Setting</th> <th></th> </tr> </thead> <tbody> <tr> <td>0</td> <td>PID Output</td> </tr> <tr> <td>1</td> <td>PID+Main Freq</td> </tr> <tr> <td>2</td> <td>PID+EPID1 Out</td> </tr> <tr> <td>3</td> <td>PID+EPID1+Main</td> </tr> </tbody> </table> | Setting | | 0 | PID Output | 1 | PID+Main Freq | 2 | PID+EPID1 Out | 3 | PID+EPID1+Main |
| Setting | | | | | | | | | | | |
| 0 | PID Output | | | | | | | | | | |
| 1 | PID+Main Freq | | | | | | | | | | |
| 2 | PID+EPID1 Out | | | | | | | | | | |
| 3 | PID+EPID1+Main | | | | | | | | | | |

| Code | Description | | | | | | | | | | | | | | | | | | | | | | | | | | | | | | | | | | | | | | | | | | | | | | | | | | | | | | | | | | | | | | | | | | | | | | | | | | | | | | | | | | | | | | | | |
|---|--|---------|---|--|--|---|------|----|--|---|---|----|--------------------------------------|---|-----|----|-----|---|----|----|-----|---|----|----|-----|---|------|----|------|---|-----|----|------|---|-----|----|------|---|------|----|------|---|----|----|------|----|-----|----|------|----|----|----|------|----|-----|----|---|----|---|----|--|----|---|----|------|----|----|----|------|----|----|----|------|----|-----|----|------|----|----|----|-----|----|-----|----|-----|----|--------------------------------------|--|--|
| | 4 PID or Main | | | | | | | | | | | | | | | | | | | | | | | | | | | | | | | | | | | | | | | | | | | | | | | | | | | | | | | | | | | | | | | | | | | | | | | | | | | | | | | | | | | | | | | | |
| PID-36 PID Out Inv | When PID-36 (PID Out Inv) is set to 'Yes,' the difference (error) between the reference and the feedback is set as the feedback-reference value. | | | | | | | | | | | | | | | | | | | | | | | | | | | | | | | | | | | | | | | | | | | | | | | | | | | | | | | | | | | | | | | | | | | | | | | | | | | | | | | | | | | | | | | | |
| PID-37 PID Out Scale | Adjusts the volume of the controller output. | | | | | | | | | | | | | | | | | | | | | | | | | | | | | | | | | | | | | | | | | | | | | | | | | | | | | | | | | | | | | | | | | | | | | | | | | | | | | | | | | | | | | | | | |
| PID-40-46 Step Ref 1-7 | Sets the PID reference by multi-function input settings at IN 65-71. | | | | | | | | | | | | | | | | | | | | | | | | | | | | | | | | | | | | | | | | | | | | | | | | | | | | | | | | | | | | | | | | | | | | | | | | | | | | | | | | | | | | | | | | |
| D-50 PID Unit Sel | <p>Sets the unit for the control variable. 0: CUST is a custom unit defined by the user.</p> <table border="1"> <thead> <tr> <th colspan="4">Setting</th> </tr> </thead> <tbody> <tr><td>0</td><td>CUST</td><td>21</td><td>m³/m(m³/min)</td></tr> <tr><td>1</td><td>%</td><td>22</td><td>m³/h(m³/h)</td></tr> <tr><td>2</td><td>PSI</td><td>23</td><td>l/s</td></tr> <tr><td>3</td><td>°F</td><td>24</td><td>l/m</td></tr> <tr><td>4</td><td>°C</td><td>25</td><td>l/h</td></tr> <tr><td>5</td><td>inWC</td><td>26</td><td>kg/s</td></tr> <tr><td>6</td><td>inM</td><td>27</td><td>kg/m</td></tr> <tr><td>7</td><td>Bar</td><td>28</td><td>kg/h</td></tr> <tr><td>8</td><td>mBar</td><td>29</td><td>gl/s</td></tr> <tr><td>9</td><td>Pa</td><td>30</td><td>gl/m</td></tr> <tr><td>10</td><td>kPa</td><td>31</td><td>gl/h</td></tr> <tr><td>11</td><td>Hz</td><td>32</td><td>ft/s</td></tr> <tr><td>12</td><td>Rpm</td><td>33</td><td>f³/s(ft³/min)</td></tr> <tr><td>13</td><td>V</td><td>34</td><td>f³/h (ft³/h)</td></tr> <tr><td>14</td><td>l</td><td>35</td><td>lb/s</td></tr> <tr><td>15</td><td>kW</td><td>36</td><td>lb/m</td></tr> <tr><td>16</td><td>HP</td><td>37</td><td>lb/m</td></tr> <tr><td>17</td><td>mpm</td><td>38</td><td>lb/h</td></tr> <tr><td>18</td><td>ft</td><td>39</td><td>ppm</td></tr> <tr><td>19</td><td>m/s</td><td>40</td><td>pps</td></tr> <tr><td>20</td><td>m³/s(m³/S)</td><td></td><td></td></tr> </tbody> </table> | Setting | | | | 0 | CUST | 21 | m ³ /m(m ³ /min) | 1 | % | 22 | m ³ /h(m ³ /h) | 2 | PSI | 23 | l/s | 3 | °F | 24 | l/m | 4 | °C | 25 | l/h | 5 | inWC | 26 | kg/s | 6 | inM | 27 | kg/m | 7 | Bar | 28 | kg/h | 8 | mBar | 29 | gl/s | 9 | Pa | 30 | gl/m | 10 | kPa | 31 | gl/h | 11 | Hz | 32 | ft/s | 12 | Rpm | 33 | f ³ /s(ft ³ /min) | 13 | V | 34 | f ³ /h (ft ³ /h) | 14 | l | 35 | lb/s | 15 | kW | 36 | lb/m | 16 | HP | 37 | lb/m | 17 | mpm | 38 | lb/h | 18 | ft | 39 | ppm | 19 | m/s | 40 | pps | 20 | m ³ /s(m ³ /S) | | |
| Setting | | | | | | | | | | | | | | | | | | | | | | | | | | | | | | | | | | | | | | | | | | | | | | | | | | | | | | | | | | | | | | | | | | | | | | | | | | | | | | | | | | | | | | | | | |
| 0 | CUST | 21 | m ³ /m(m ³ /min) | | | | | | | | | | | | | | | | | | | | | | | | | | | | | | | | | | | | | | | | | | | | | | | | | | | | | | | | | | | | | | | | | | | | | | | | | | | | | | | | | | | | | | |
| 1 | % | 22 | m ³ /h(m ³ /h) | | | | | | | | | | | | | | | | | | | | | | | | | | | | | | | | | | | | | | | | | | | | | | | | | | | | | | | | | | | | | | | | | | | | | | | | | | | | | | | | | | | | | | |
| 2 | PSI | 23 | l/s | | | | | | | | | | | | | | | | | | | | | | | | | | | | | | | | | | | | | | | | | | | | | | | | | | | | | | | | | | | | | | | | | | | | | | | | | | | | | | | | | | | | | | |
| 3 | °F | 24 | l/m | | | | | | | | | | | | | | | | | | | | | | | | | | | | | | | | | | | | | | | | | | | | | | | | | | | | | | | | | | | | | | | | | | | | | | | | | | | | | | | | | | | | | | |
| 4 | °C | 25 | l/h | | | | | | | | | | | | | | | | | | | | | | | | | | | | | | | | | | | | | | | | | | | | | | | | | | | | | | | | | | | | | | | | | | | | | | | | | | | | | | | | | | | | | | |
| 5 | inWC | 26 | kg/s | | | | | | | | | | | | | | | | | | | | | | | | | | | | | | | | | | | | | | | | | | | | | | | | | | | | | | | | | | | | | | | | | | | | | | | | | | | | | | | | | | | | | | |
| 6 | inM | 27 | kg/m | | | | | | | | | | | | | | | | | | | | | | | | | | | | | | | | | | | | | | | | | | | | | | | | | | | | | | | | | | | | | | | | | | | | | | | | | | | | | | | | | | | | | | |
| 7 | Bar | 28 | kg/h | | | | | | | | | | | | | | | | | | | | | | | | | | | | | | | | | | | | | | | | | | | | | | | | | | | | | | | | | | | | | | | | | | | | | | | | | | | | | | | | | | | | | | |
| 8 | mBar | 29 | gl/s | | | | | | | | | | | | | | | | | | | | | | | | | | | | | | | | | | | | | | | | | | | | | | | | | | | | | | | | | | | | | | | | | | | | | | | | | | | | | | | | | | | | | | |
| 9 | Pa | 30 | gl/m | | | | | | | | | | | | | | | | | | | | | | | | | | | | | | | | | | | | | | | | | | | | | | | | | | | | | | | | | | | | | | | | | | | | | | | | | | | | | | | | | | | | | | |
| 10 | kPa | 31 | gl/h | | | | | | | | | | | | | | | | | | | | | | | | | | | | | | | | | | | | | | | | | | | | | | | | | | | | | | | | | | | | | | | | | | | | | | | | | | | | | | | | | | | | | | |
| 11 | Hz | 32 | ft/s | | | | | | | | | | | | | | | | | | | | | | | | | | | | | | | | | | | | | | | | | | | | | | | | | | | | | | | | | | | | | | | | | | | | | | | | | | | | | | | | | | | | | | |
| 12 | Rpm | 33 | f ³ /s(ft ³ /min) | | | | | | | | | | | | | | | | | | | | | | | | | | | | | | | | | | | | | | | | | | | | | | | | | | | | | | | | | | | | | | | | | | | | | | | | | | | | | | | | | | | | | | |
| 13 | V | 34 | f ³ /h (ft ³ /h) | | | | | | | | | | | | | | | | | | | | | | | | | | | | | | | | | | | | | | | | | | | | | | | | | | | | | | | | | | | | | | | | | | | | | | | | | | | | | | | | | | | | | | |
| 14 | l | 35 | lb/s | | | | | | | | | | | | | | | | | | | | | | | | | | | | | | | | | | | | | | | | | | | | | | | | | | | | | | | | | | | | | | | | | | | | | | | | | | | | | | | | | | | | | | |
| 15 | kW | 36 | lb/m | | | | | | | | | | | | | | | | | | | | | | | | | | | | | | | | | | | | | | | | | | | | | | | | | | | | | | | | | | | | | | | | | | | | | | | | | | | | | | | | | | | | | | |
| 16 | HP | 37 | lb/m | | | | | | | | | | | | | | | | | | | | | | | | | | | | | | | | | | | | | | | | | | | | | | | | | | | | | | | | | | | | | | | | | | | | | | | | | | | | | | | | | | | | | | |
| 17 | mpm | 38 | lb/h | | | | | | | | | | | | | | | | | | | | | | | | | | | | | | | | | | | | | | | | | | | | | | | | | | | | | | | | | | | | | | | | | | | | | | | | | | | | | | | | | | | | | | |
| 18 | ft | 39 | ppm | | | | | | | | | | | | | | | | | | | | | | | | | | | | | | | | | | | | | | | | | | | | | | | | | | | | | | | | | | | | | | | | | | | | | | | | | | | | | | | | | | | | | | |
| 19 | m/s | 40 | pps | | | | | | | | | | | | | | | | | | | | | | | | | | | | | | | | | | | | | | | | | | | | | | | | | | | | | | | | | | | | | | | | | | | | | | | | | | | | | | | | | | | | | | |
| 20 | m ³ /s(m ³ /S) | | | | | | | | | | | | | | | | | | | | | | | | | | | | | | | | | | | | | | | | | | | | | | | | | | | | | | | | | | | | | | | | | | | | | | | | | | | | | | | | | | | | | | | | |
| PID-51 PID Unit Scale | Adjusts the scale to fit the unit selected at PID-50 PID Unit Sel. | | | | | | | | | | | | | | | | | | | | | | | | | | | | | | | | | | | | | | | | | | | | | | | | | | | | | | | | | | | | | | | | | | | | | | | | | | | | | | | | | | | | | | | | |
| PID-52 PID Unit 0 % PID-53 PID Unit 100% | Sets the Unit 0% and Unit 100% values as the minimum and maximum values set at PID-50. | | | | | | | | | | | | | | | | | | | | | | | | | | | | | | | | | | | | | | | | | | | | | | | | | | | | | | | | | | | | | | | | | | | | | | | | | | | | | | | | | | | | | | | | |

PID Command Block

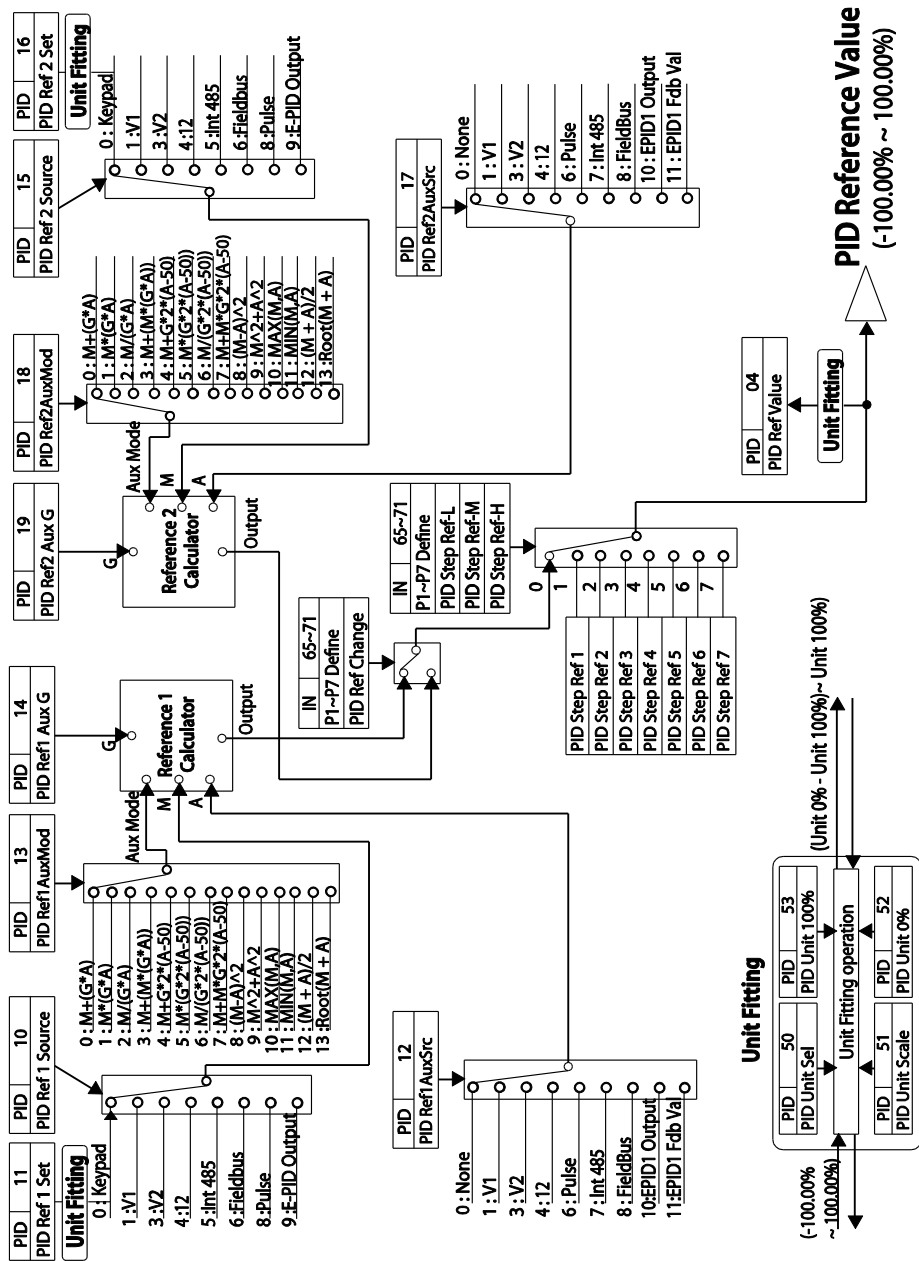

Advanced Features

PID Feedback Block

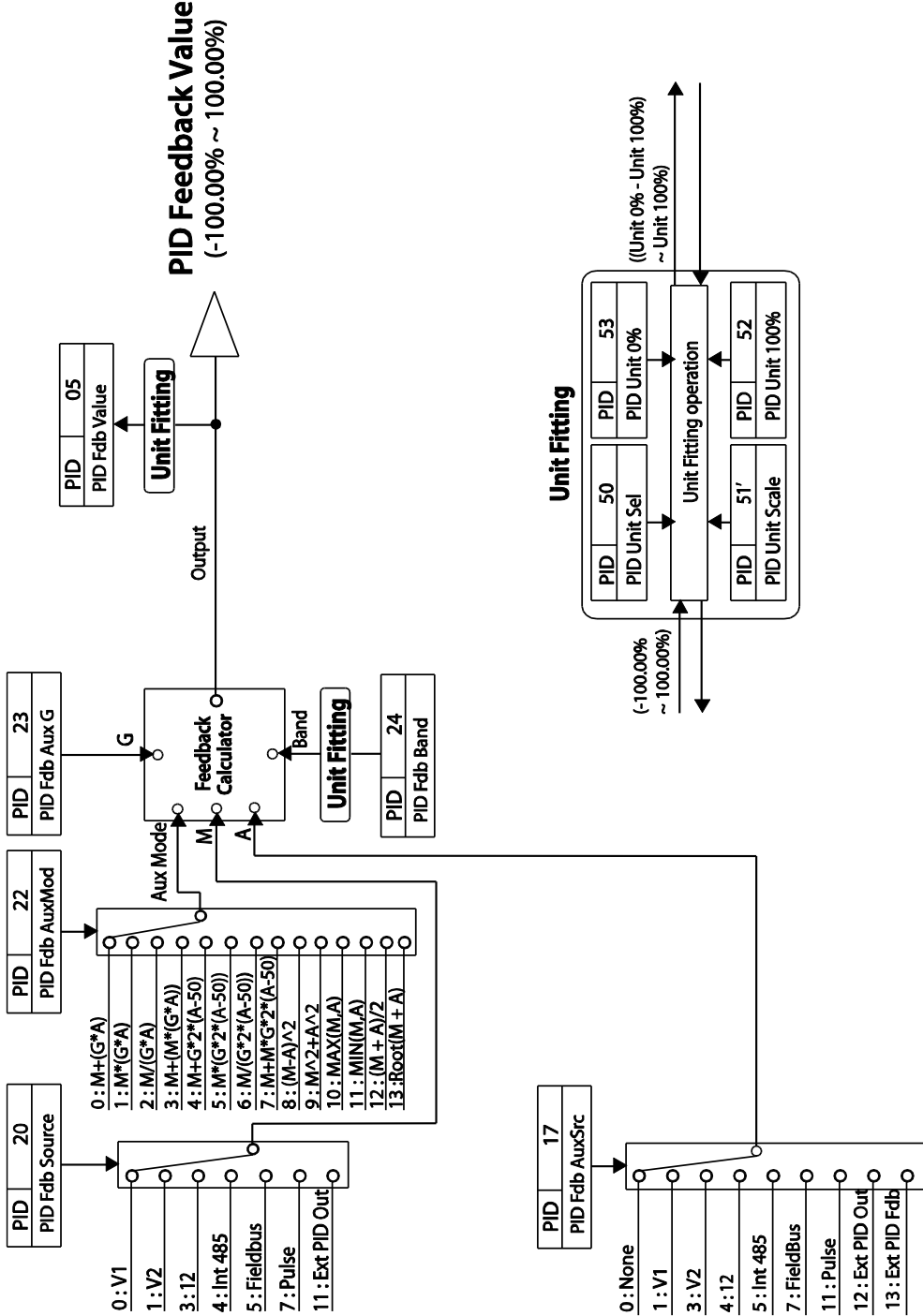

PID Output Block

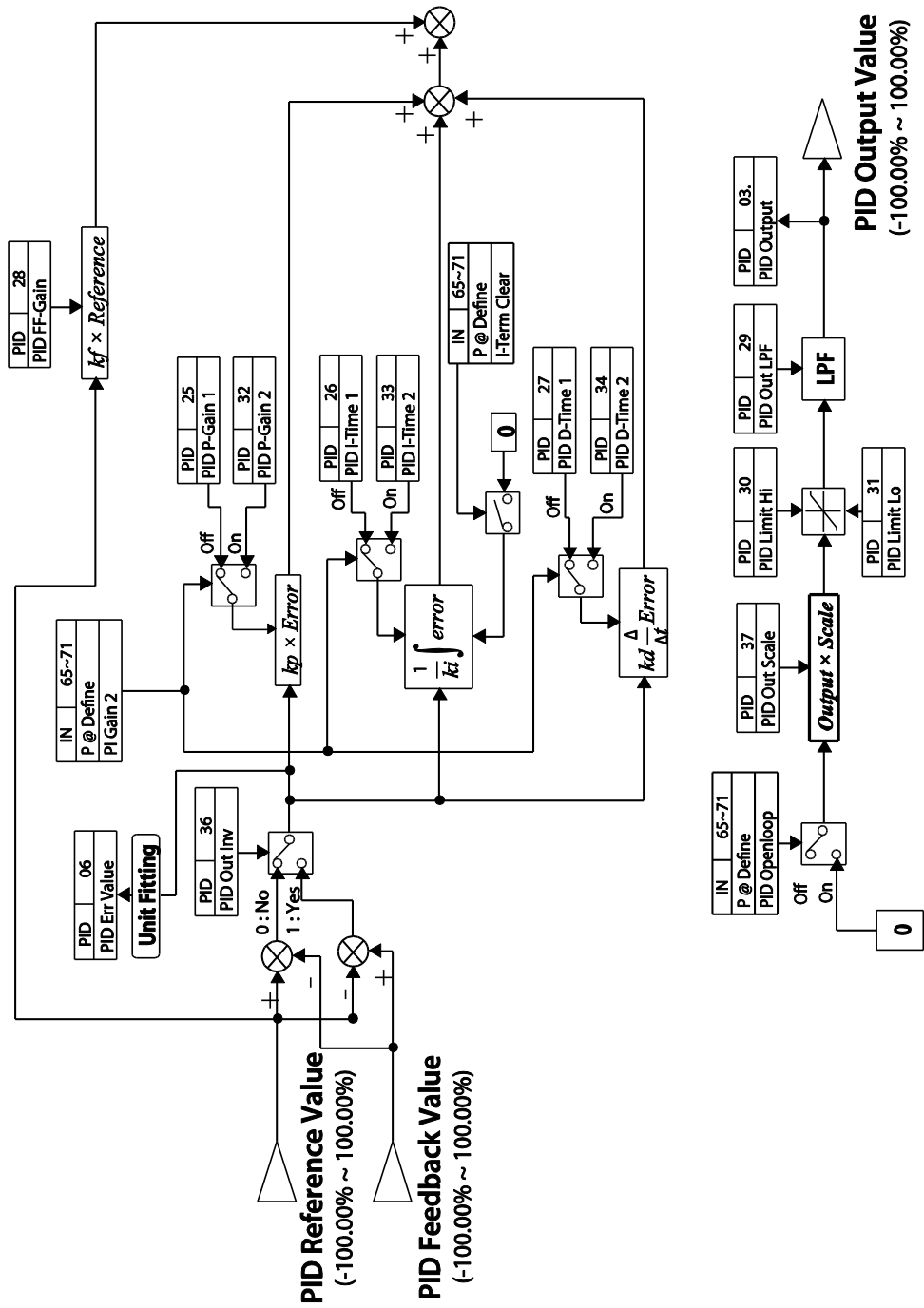

PID Output Mode Block

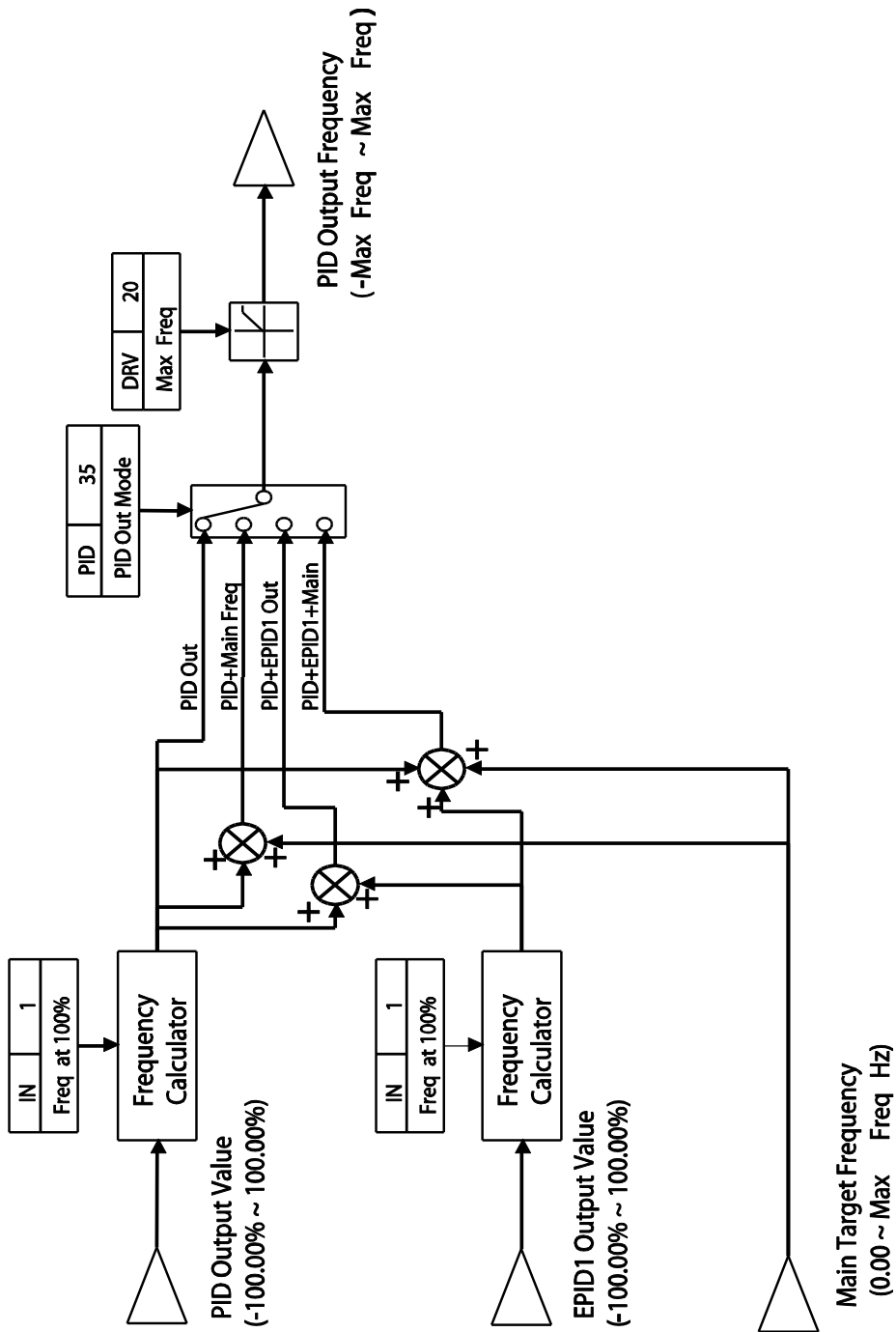

5.8.2 Soft Fill Operation

A soft fill operation is used to prevent excessive pressure from building in the pipe system at the initial stage of a pump operation. When the operation command is given, a general acceleration (without PID control) begins and continues until the output reaches the frequency set at AP1-21, for the time set at AP1-22. Then, the soft fill PID operation is performed unless the feedback value has reached the value set at AP1-23 (Soft Fill Set value). The soft fill PID operation continues until the feedback or the soft fill PID reference value reaches the value set at AP1-23 (Soft Fill Set value). When the soft fill operation ends, a normal PID operation starts.

| Group | Code | Name | LCD Display | Parameter Setting | | Setting Range | Unit |
|-------|------|-------------------------------------|----------------|-------------------|----|--------------------|------|
| AP1 | 20 | Soft Fill options | Soft Fill Sel | 0 | No | 0–1 | - |
| | 21 | Pr- PID operation frequency | Pre-PID Freq | 30.00 | | Low Freq–High Freq | Hz |
| | 22 | Pre-PID duration | Pre-PID Delay | 60.0 | | 600.0 | sec |
| | 23 | Soft fill escape value | Soft Fill Set | 20.00 | | Unit Min–Unit Max | % |
| | 24 | Soft fill reference increment | Fill Step Set | 2.00 | | 0–Unit Band | % |
| | 25 | Soft fill reference increment cycle | Fill Step Time | 20 | | 0–9999 | sec |
| | 26 | Soft fill feedback difference | Fill Fdb Diff | 0.00 | | 0–Unit Band | % |

Soft Fill Operation Setting Details

| Code | Description |
|-------------------------|--|
| AP1-20 Soft Fill Sel | Enables or disables the soft fill PID. |
| AP1-21 Pre-PID Freq | Sets the frequency range for a general acceleration without PID control. If AP1-21 (Pre-PID Freq) is set to 30 Hz, general operation is performed until the PID feedback reaches the value set at AP1-23 (Soft Fill Set). However, if the PID reference or feedback exceeds the value set at AP1-23 during the pre-PID operation, a normal PID operation starts immediately. |
| AP1-22 Pre-PID Delay | In general, a PID operation starts when the feedback volume (controlled variables) of PID controller exceeds the value set at AP1-23. However, if |

| Code | Description |
|--|--|
| AP1-23 Soft Fill Set | AP1-22 (Pre-PID Delay) is set, the feedback after the set time becomes the default value for the soft fill PID reference, and the inverter starts the soft fill operation. When the feedback or the Soft Fill PID Reference exceeds the Soft Fill Set value, the soft fill operation ends and a normal process PID operation begins. |
| AP1-24 Fill Step Set AP1-25 Fill Step Time AP1-26 Fill Fdb Diff | The Soft Fill PID Reference increases each time the set time [at AP1-25 (Fill Step Time)] is elapsed, by the amount set at AP1-24 (Fill Step Set). However, note that if the difference between the Soft Fill PID Reference value and the feedback value is greater than the value set at AP1-26 (Fill Fdb Diff value), the Soft Fill PID Reference value does not increase. |

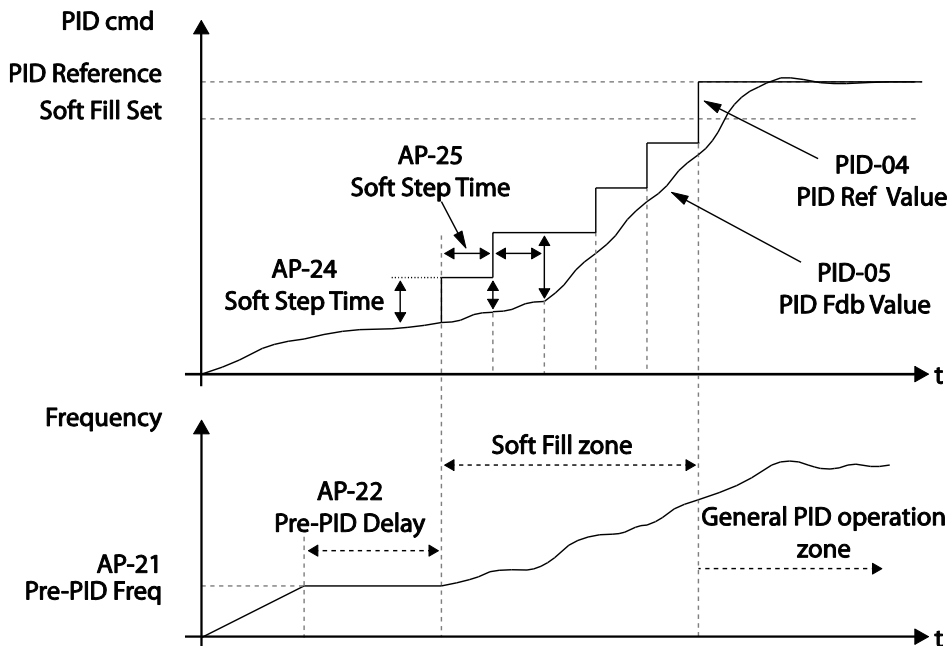

When a PID process is performed after the soft fill PID operation, the PID Reference value becomes the PID-11 PID Ref1 Set value.

5.8.3 PID Sleep Mode

If an operation continues at a frequency lower than the PID operation conditions, a boost operation is performed to extend sleep mode by raising the PID Reference, and then the inverter enters PID sleep mode. In PID sleep mode, the inverter resumes PID operation when the PID feedback falls below the PID Wakeup level and maintains the condition for the time set at AP1-09 (PID WakeUp1 DT) or AP1-13 (PID WakeUp2DT).

Note

PID Wakeup level may be calculated using the following formula:

PID Wakeup Level = PID-04 (PID Ref Value)–AP1-10 (PID WakeUp1Dev) or, PID-04 (PID Ref Value) - AP1-14 PID (WakeUp2Dev).

Two sets of configurations are available in PID sleep mode for sleep mode frequency, sleep mode delay time, wakeup variation, and wakeup delay time. One of the two configurations may be selected depending on the multi-function input terminal configuration and input conditions.

| Group | Code | Name | LCD Displays | Parameter Setting | Setting Range | Unit |
|-------|------|-----------------------------|----------------|-------------------|--------------------------|------|
| AP1 | 05 | Sleep boost settings | Sleep Bst Set | 0.00 | 0–Unit Max | Unit |
| | 06 | Sleep boost speed | Sleep Bst Freq | 60.00 | 0.00, Low Freq–High Freq | Hz |
| | 07 | PID sleep mode 1 delay time | PID Sleep 1 DT | 20.0 | 0–6000.0 | sec |
| | 08 | PID sleep mode 1 frequency | PID Sleep1Freq | 0.00 | 0.00, Low Freq–High Freq | Hz |
| | 09 | PID wakeup 1 delay time | PID WakeUp1 DT | 20.0 | 0–6000.0 | sec |
| | 10 | PID wakeup 1 value | PID WakeUp1Dev | 20.00 | 0–Unit Band | Unit |
| | 11 | PID sleep mode 2 delay time | PID Sleep 2 DT | 20.0 | 0–6000.0 | sec |
| | 12 | PID sleep mode 2 frequency | PID Sleep2Freq | 0.00 | 0.00, Low Freq–High Freq | Hz |

| Group | Code | Name | LCD Displays | Parameter Setting | | Setting Range | Unit |
|-------|------|-------------------------|----------------|-------------------|----|---------------|------|
| | 13 | PID wakeup 2 delay time | PID WakeUp2 DT | 20.0 | | 0–6000.0 | sec |
| | 14 | PID wakeup 2 value | PID WakeUp2Dev | 20.00 | | 0–Unit Band | Unit |
| | 20 | Soft Fill options | Soft Fill Sel | 0 | No | 0–1 | - |

PID Operation Sleep Mode Setting Details

| Code | Description |
|--|---|
| AP1-05 Sleep Bst Set | Sets the sleep boost volume. Feedback must reach the boost level (PID Reference+Sleep Bst Set) for the inverter to enter the Sleep Mode. |
| AP1-06 Sleep Bst Freq | Sets the inverter operation frequency to reach sleep boost level. |
| AP1-07 PID Sleep1 DT AP1-11 PID Sleep2 DT AP1-08 PID Sleep1Freq AP1-12 PID Sleep2Freq | If the operating frequency stays below the frequencies set at AP1-08 and AP1-12 for the set times at AP1-07 and AP1-11, the inverter accelerates to the PID sleep boost frequency (PID Sleep Bst Freq). Then, when the feedback reaches the value set at the boost level, the inverter enters standby mode. |
| AP1-09 PID WakeUp1 DT AP1-13 PID WakeUp2 DT AP1-10 PID WakeUp1Dev AP1-14 PID WakeUp2Dev | Sets the reference for PID operation in PID sleep mode. PID operation resumes when PID feedback variation (from the PID reference) exceeds the values set at AP1-10 and AP1-14, and maintains the condition for times set at AP1-09 or AP1-13. |
| IN-65–71 P1–7 Define | When the PID Sleep Wake 2 terminal is set and input, PID operation sleep mode is operated based on the parameter settings at AP1-11–14. |

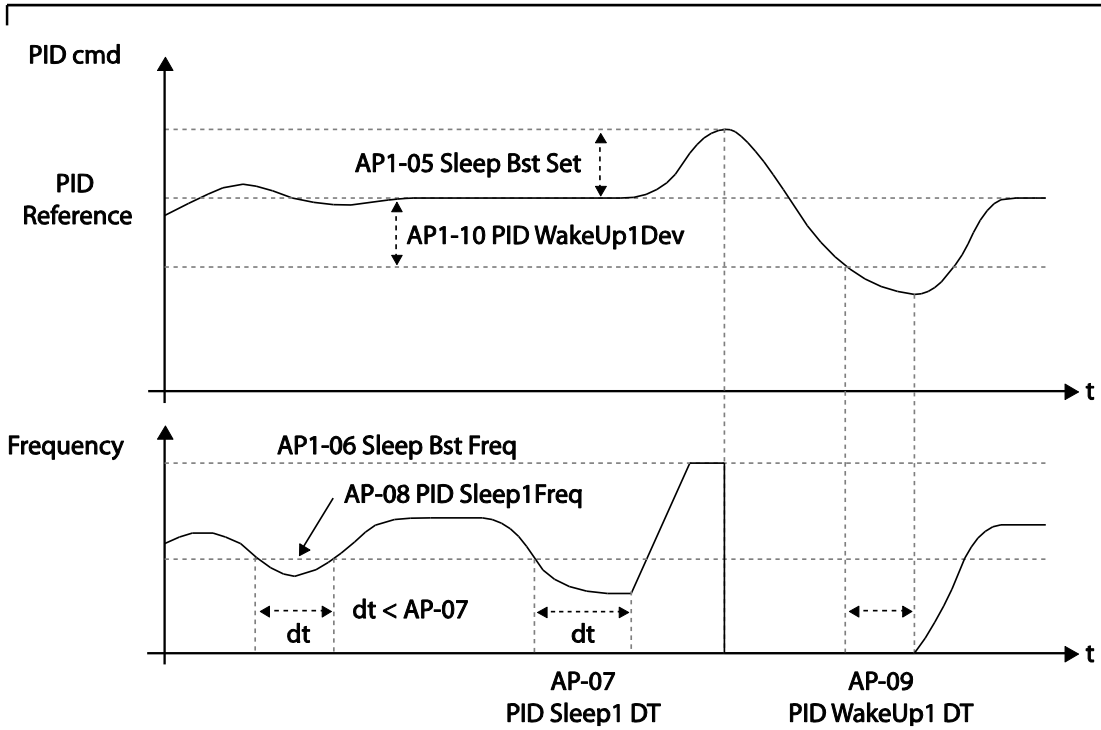

5.8.4 PID Switching (PID Openloop)

When one of the multi-function terminals (IN-65–71) is set to '25 (PID Openloop)' and is turned on, the PID operation stops and is switched to general operation. When the terminal turns off, the PID operation starts again.

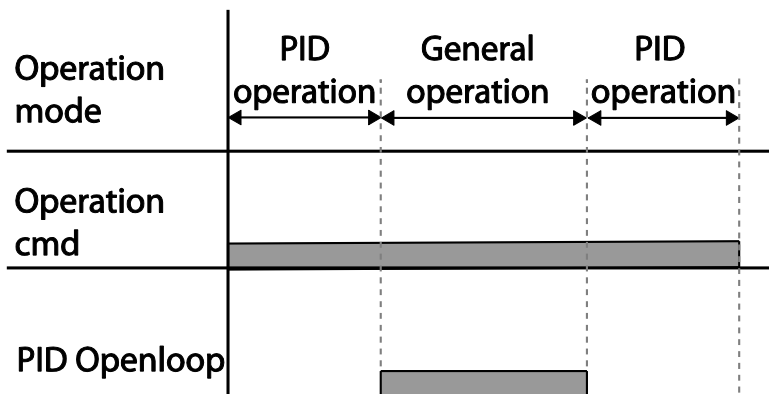

5.9 External PID

External PID refers to the PID features other than the basic PID features required to control the inverter. The following table shows the areas where external PID controls can be applied.

| Purpose | Function |
|---------------------|---|
| Speed Control | Controls speed by monitoring the current speed levels of the equipment or machinery being controlled. Control maintains consistent speed or operates at the target speed. |
| Pressure Control | Controls pressure by monitoring the current pressure levels of the equipment or machinery being controlled. Control maintains consistent pressure or operates at the target pressure. |
| Flow Control | Controls flow by monitoring the amount of flow in the equipment or machinery to be controlled. Control maintains consistent flow or operates at a target flow. |
| Temperature Control | Controls temperature by monitoring the current temperature levels of the equipment or machinery to be controlled. Control maintains a consistent temperature or operates at a target temperature. |

Depending on the PID output mode, the EPID output value can be overlapped to the PID output. External output is also available through the analog output settings at OUT-01 and OUT-07.

| Group | Code | Name | LCD Display | Parameter Setting | | Setting Range | Unit |
|-------|------|---------------------------------|---------------|-------------------|--------|-------------------|------|
| EPI | 00 | Jump Code | Jump Code | 40 | | 1–99 | |
| | 01 | EPID 1 Mode Selection | EPID1 Mode | 0 | None | 0–3 | |
| | 02 | EPID1output monitor value | EPID1 Output | 0.00 | | -100.00–100.00% | Unit |
| | 03 | EPID1 reference monitor value | EPID1 Ref Val | - | | - | - |
| | 04 | EPID1 feedback monitor value | EPID1 Fdb Val | - | | - | - |
| | 05 | EPID1error monitor value | EPID1 Err Val | - | | - | - |
| | 06 | EPID1 command source selection | EPID1 Ref Src | 0 | Keypad | 0–10 | - |
| | 07 | EPID1 keypad command value | EPID1 Ref Set | Unit Min | | Unit Min–Unit Max | % |
| | 08 | EPID1 feedback source selection | EPID1 Fdb Src | 0 | V1 | 0–9 | - |

| Group | Code | Name | LCD Display | Parameter Setting | Setting Range | Unit |
|-------|------|----------------------------|----------------|---------------------------------------|--|------|
| | 09 | EPID1 proportional gain | EPID1 P-Gain | 50.0 | 0.0–300.0% | Unit |
| | 10 | EPID1 integral time | EPID1 I-Time | 10.0 | 0.0–200.0 | Sec |
| | 11 | EPID1 differentiation time | EPID1 D-Time | 0.00 | 0–0.00 | Sec |
| | 12 | EPID1 feed-forward gain | EPID1 FF-Gain | 0.0 | 0.0–1000.0 | Unit |
| | 13 | EPID1 output filter | EPID1 Out LPF | 0 | 0–10.00 | Sec |
| | 14 | EPID1 output upper limit | EPID1 Limit Hi | 100.00 | EPID1 Limit Lo–100.00 | - |
| | 15 | EPID1 lower limit | EPID1 Limit Lo | 0.00 | -100.00–EPID1 Limit Hi | - |
| | 16 | EPID1 output inverse | EPID1 Out Inv | 0 No | 0–1 | - |
| | 17 | EPID1 unit | EPID1 Unit Sel | 1: % | Refer to EPID unit details table | - |
| | 18 | EEPID1 unit scale | EPID1 Unit Scl | 2: X1 | 0: X100 1: X10 2: X1 3: X0.1 4: X0.01 | - |
| | 19 | EPID1 unit 0% value | EPID1 Unit0% | Differs depending on the unit setting | X100: -32000–Unit 100% X10: -3200.0–Unit 100% X1: -320.00–Unit 100% X0.1: -32.000–Unit 100% X0.01: -3.2000–Unit 100% | - |
| | 20 | EPID1 unit 100% value | EPID1 Unit100% | Differs depending on the unit setting | X100: Unit 0%–32000 X10: Unit 0%–3200.0 X1: Unit 0%–320.00 X0.1: Unit | - |

| Group | Code | Name | LCD Display | Parameter Setting | | Setting Range | Unit |
|-------|------|---------------------------------|----------------|-------------------|--------|--|------|
| | | | | | | 0%–32.000 X0.01: Unit 0%– 3.2000 | |
| | 31 | EPID2 Mode selection | EPID2 Mode | 0 | None | 0–3 | - |
| | 32 | EPID2 output monitor value | EPID2 Output | 0.00 | | -100.00– 100.00% | Unit |
| | 33 | EPID2 reference monitor value | EPID2 Ref Val | - | | - | - |
| | 34 | EPID2 feedback monitor value | EPID2 Fdb Val | - | | - | - |
| | 35 | EPID2 error monitor value | EPID2 Err Val | - | | - | - |
| | 36 | EPID2 command source selection | EPID2 Ref Src | 0 | Keypad | 0–10 | - |
| | 37 | EPID2 keypad command value | EPID2 Ref Set | Unit Min | | Unit Min–Unit Max | Unit |
| | 38 | EPID2 feedback source selection | EPID2 Fdb Src | 0 | V1 | 0–9 | - |
| | 39 | EPID2 proportional gain | EPID2 P-Gain | 50.0 | | 0.0–300.0 | Unit |
| | 40 | EPID2 integral time | EPID2 I-Time | 10.0 | | 0.0–200.0 | Sec |
| | 41 | EPID2 differentiation time | EPID2 D-Time | 0.00 | | 0–1.00 | Sec |
| | 42 | EPID2 feed-forward gain | EPID2 FF-Gain | 0.0 | | 0.0–1000.0 | Unit |
| | 43 | EPID2 output filter | EPID2 Out LPF | 0 | | 0–10.00 | Sec |
| | 44 | EPID2 output upper limit | EPID2 Limit Hi | 100.00 | | EPID2 Limit Lo– 100.00 | - |
| | 45 | EPID2 output lower limit | EPID2 Limit Lo | 0.00 | | -100.00–EPID2 Limit Hi | - |
| | 46 | EPID2 output | EPID2 Out | 0: No | | 0 No | - |

| Group | Code | Name | LCD Display | Parameter Setting | Setting Range | Unit |
|-------|------|-----------------------|----------------|---------------------------------------|---|------|
| | | inverse | Inv | | 1 Yes | |
| | 47 | EPID2 unit | EPID2 Unit Sel | 0: CUST | Refer to EPID unit details table | - |
| | 48 | EPID2 unit scale | EPID2 Unit Scl | 2: X1 | 0: X100 1: X10 2: X1 3: X0.1 4: X0.01 | - |
| | 49 | EPID2 unit 0% value | EPID2 Unit0% | Differs depending on the unit setting | X100: -32000–Unit 100% X10: -3200.0–Unit 100% X1: -320.00–Unit 100% X0.1: -32.000–Unit -100% X0.01: -3.2000–Unit 100% | - |
| | 50 | EPID2 unit 100% value | EPID2 Unit100% | Differs depending on the unit setting | X100: Unit 0%–32000 X10: Unit 0%–3200.0 X1: Unit 0%–320.00 X0.1: Unit 0%–32.000 X0.01: Unit 0%–3.2000 | - |

Note

- The EPID1–2 output (EPID OUT) is bipolar, and is limited by the EPI-14 (EPID 1 Limit Hi) and EPI-15 (EPID 1 Limit Lo) settings.
- The following are the variables used in PID operation, and how they are calculated:
 - Unit MAX = EPID1 (EPID2) Unit 100% (PID-68)
 - Unit Min = (2xEPID1 (EPID2) Unit0%-EPID1 (EPID2) Unit 100%)
 - Unit Default = (EPID1 (EPID2) Unit 100%-EPID1 (EPID2) Unit 0%)/2

EPID Basic Operation Setting Details

| Code | Description | | | | | | | | | | | | | | | | | | | | | | |
|------------------------|---|---|--|---|--------|--------------------|---|-----------|---------------------------------|---|------------|--|---|--------------|---|----------|-----------------------|---|----------|---|---|-------|--|
| EPI-01 EPID1 Mode | Sets the EPID1 modes. | | | | | | | | | | | | | | | | | | | | | | |
| | <table border="1"> <thead> <tr> <th>Setting</th> <th>Function</th> </tr> </thead> <tbody> <tr> <td>0</td> <td>None</td> <td>EPID1 is not used.</td> </tr> <tr> <td>1</td> <td>Always On</td> <td>EPID1 operates at all times.</td> </tr> <tr> <td>2</td> <td>During Run</td> <td>Operates only when the inverter is running.</td> </tr> <tr> <td>3</td> <td>DI Dependent</td> <td>Operates when terminal input (EPID1 Run) is on.</td> </tr> </tbody> </table> | Setting | Function | 0 | None | EPID1 is not used. | 1 | Always On | EPID1 operates at all times. | 2 | During Run | Operates only when the inverter is running. | 3 | DI Dependent | Operates when terminal input (EPID1 Run) is on. | | | | | | | | |
| | Setting | Function | | | | | | | | | | | | | | | | | | | | | |
| | 0 | None | EPID1 is not used. | | | | | | | | | | | | | | | | | | | | |
| | 1 | Always On | EPID1 operates at all times. | | | | | | | | | | | | | | | | | | | | |
| 2 | During Run | Operates only when the inverter is running. | | | | | | | | | | | | | | | | | | | | | |
| 3 | DI Dependent | Operates when terminal input (EPID1 Run) is on. | | | | | | | | | | | | | | | | | | | | | |
| EPI-02 PID Output | Displays the existing output value for the EPID controller. The unit, gain, and scale that were set in the EPID group are applied on the display. | | | | | | | | | | | | | | | | | | | | | | |
| EPI-03 EPID Ref Value | Displays the existing reference value set for the EPID controller. The unit, gain, and scale that were set in the EPID group are applied on the display. | | | | | | | | | | | | | | | | | | | | | | |
| EPI-04 EPID1 Fdb Value | Displays the existing feedback value set for the EPID controller. The unit, gain, and scale that were set in the EPID group are applied on the display. | | | | | | | | | | | | | | | | | | | | | | |
| EPI-05 EPID1 Err Value | Displays the difference between the existing reference and the feedback (error value). The unit, gain, and scale that were set in the PID group are applied on the display. | | | | | | | | | | | | | | | | | | | | | | |
| EPI1-06 EPID1 Ref Src | Selects the reference input for the EPID control. If the V1 terminal is set to an EPID1 feedback source (EPID1 F/B Source), V1 cannot be set as the EPID1 reference source (EPID1 Ref Source). To set V1 as a reference source, change the feedback source. | | | | | | | | | | | | | | | | | | | | | | |
| | <table border="1"> <thead> <tr> <th>Setting</th> <th>Function</th> </tr> </thead> <tbody> <tr> <td>0</td> <td>Keypad</td> <td>Keypad</td> </tr> <tr> <td>1</td> <td>V1</td> <td>-10-10 V input voltage terminal</td> </tr> <tr> <td>3</td> <td>V2</td> <td rowspan="2">I2 analog input terminal [When analog voltage/current input terminal selection switch (SW2) at the terminal block is set to I (current), input 0-20 mA current. If it is set to V (voltage), input 0-10 V]</td> </tr> <tr> <td>4</td> <td>I2</td> </tr> <tr> <td>5</td> <td>Int. 485</td> <td>RS-485 input terminal</td> </tr> <tr> <td>7</td> <td>FieldBus</td> <td>Communication command via a communication option card</td> </tr> <tr> <td>8</td> <td>Pulse</td> <td>TI Pulse input terminal (0-32 kHz Pulse input)</td> </tr> </tbody> </table> | Setting | Function | 0 | Keypad | Keypad | 1 | V1 | -10-10 V input voltage terminal | 3 | V2 | I2 analog input terminal [When analog voltage/current input terminal selection switch (SW2) at the terminal block is set to I (current), input 0-20 mA current. If it is set to V (voltage), input 0-10 V] | 4 | I2 | 5 | Int. 485 | RS-485 input terminal | 7 | FieldBus | Communication command via a communication option card | 8 | Pulse | TI Pulse input terminal (0-32 kHz Pulse input) |
| | Setting | Function | | | | | | | | | | | | | | | | | | | | | |
| | 0 | Keypad | Keypad | | | | | | | | | | | | | | | | | | | | |
| | 1 | V1 | -10-10 V input voltage terminal | | | | | | | | | | | | | | | | | | | | |
| | 3 | V2 | I2 analog input terminal [When analog voltage/current input terminal selection switch (SW2) at the terminal block is set to I (current), input 0-20 mA current. If it is set to V (voltage), input 0-10 V] | | | | | | | | | | | | | | | | | | | | |
| | 4 | I2 | | | | | | | | | | | | | | | | | | | | | |
| | 5 | Int. 485 | RS-485 input terminal | | | | | | | | | | | | | | | | | | | | |
| | 7 | FieldBus | Communication command via a communication option card | | | | | | | | | | | | | | | | | | | | |
| 8 | Pulse | TI Pulse input terminal (0-32 kHz Pulse input) | | | | | | | | | | | | | | | | | | | | | |
| EPI-07 EPID1 Ref Set | Set the EPI control reference type (EPI-06) to '0 (Keypad)' to enter the reference value. | | | | | | | | | | | | | | | | | | | | | | |

| Code | Description | | | | | | | | | | | | | | | | | | | | |
|---|--|--|----------|----------|---|--------|--------|---|----|---------------------------------|---|----|--|---|----|---|----------|-----------------------|---|----------|---|
| EPI-09 EPID1 P-Gain | Sets the output ratio for differences (errors) between the reference and feedback. If the P-Gain x 2 is set to 50%, then 50% of the error is output. The setting range for P-Gain is 0.0-1,000%. | | | | | | | | | | | | | | | | | | | | |
| EPI-08 EDPID1 Fdb Src | <p>Selects the feedback input for the EPID control. When the V1 terminal is set to an EPID feedback source (PID F/B Source), V1 cannot be set as the PID reference source (PID Ref Source). To set V1 as a reference source, change the feedback source.</p> <table border="1" data-bbox="428 595 1232 958"> <thead> <tr> <th data-bbox="428 595 504 629">Setting</th> <th data-bbox="504 595 662 629">Function</th> <th data-bbox="662 595 1232 629">Function</th> </tr> </thead> <tbody> <tr> <td data-bbox="428 629 504 664">0</td> <td data-bbox="504 629 662 664">Keypad</td> <td data-bbox="662 629 1232 664">Keypad</td> </tr> <tr> <td data-bbox="428 664 504 699">1</td> <td data-bbox="504 664 662 699">V1</td> <td data-bbox="662 664 1232 699">-10-10 V input voltage terminal</td> </tr> <tr> <td data-bbox="428 699 504 734">3</td> <td data-bbox="504 699 662 734">V2</td> <td data-bbox="662 699 1232 855" rowspan="2">I2 analog input terminal [When analog voltage/current input terminal selection switch (SW4) at the terminal block is set to I (current), input 0-20 mA current. If it is set to V (voltage), input 0-10 V voltage]</td> </tr> <tr> <td data-bbox="428 734 504 768">4</td> <td data-bbox="504 734 662 768">I2</td> </tr> <tr> <td data-bbox="428 768 504 803">5</td> <td data-bbox="504 768 662 803">Int. 485</td> <td data-bbox="662 768 1232 803">RS-485 input terminal</td> </tr> <tr> <td data-bbox="428 803 504 958">7</td> <td data-bbox="504 803 662 958">FieldBus</td> <td data-bbox="662 803 1232 958">Communication command via a communication option card</td> </tr> </tbody> </table> | Setting | Function | Function | 0 | Keypad | Keypad | 1 | V1 | -10-10 V input voltage terminal | 3 | V2 | I2 analog input terminal [When analog voltage/current input terminal selection switch (SW4) at the terminal block is set to I (current), input 0-20 mA current. If it is set to V (voltage), input 0-10 V voltage] | 4 | I2 | 5 | Int. 485 | RS-485 input terminal | 7 | FieldBus | Communication command via a communication option card |
| Setting | Function | Function | | | | | | | | | | | | | | | | | | | |
| 0 | Keypad | Keypad | | | | | | | | | | | | | | | | | | | |
| 1 | V1 | -10-10 V input voltage terminal | | | | | | | | | | | | | | | | | | | |
| 3 | V2 | I2 analog input terminal [When analog voltage/current input terminal selection switch (SW4) at the terminal block is set to I (current), input 0-20 mA current. If it is set to V (voltage), input 0-10 V voltage] | | | | | | | | | | | | | | | | | | | |
| 4 | I2 | | | | | | | | | | | | | | | | | | | | |
| 5 | Int. 485 | RS-485 input terminal | | | | | | | | | | | | | | | | | | | |
| 7 | FieldBus | Communication command via a communication option card | | | | | | | | | | | | | | | | | | | |
| EPI-10 EPID1 I- Time | <p>Sets the time to output accumulated errors. When the error is 100%, the time taken for 100% output is set. When the integral time (EPID I-Time) is set to 1 second, 100% output occurs after 1 second of the error remaining at 100%. Differences in a normal state can be reduced by EPID I Time.</p> <p>All the accumulated errors can be deleted by setting the multi-function terminal block to '42 (EPID1 ITerm Clr)' or '48 (EPID2 ITerm Clr)'.</p> | | | | | | | | | | | | | | | | | | | | |
| EPI-11 EPI1 D-Time | Sets the output volume for the rate of change in errors. If the differential time (EPID1 D-Time) is set to 1 ms and the rate of change in errors per sec is 100%, output occurs at 1% per 10 ms. | | | | | | | | | | | | | | | | | | | | |
| EPI-12 EPID1 FF-Gain | Sets the ratio that adds the target to the EPID output. Adjusting this value leads to a faster response. | | | | | | | | | | | | | | | | | | | | |
| EPI-13 EPID1 Out LPF | Used when the output of the EPID controller changes too fast or the entire system is unstable, due to severe oscillation. In general, a lower value (default value=0) is used to speed up response time, but in some cases a higher value increases stability. The higher the value, the more stable the EPID controller output is, but the slower the response time. | | | | | | | | | | | | | | | | | | | | |
| EPI-14 EPID1 Limit Hi, EPI-15 EPID1 Limit Lo | Limits the output of the controller. | | | | | | | | | | | | | | | | | | | | |

| Code | Description | | | | | | | | | | | | | | | | | | | | | | | | | | | | | | | | | | | | | | | | | | | | | | | | | | | | | | | | | | | | | | | | | | | | | | | | | | | | | | | | | | | | | | | | |
|---|---|---------|---|--|--|---|------|----|--|---|---|----|--------------------------------------|---|-----|----|-----|---|----|----|-----|---|----|----|-----|---|------|----|------|---|-----|----|------|---|-----|----|------|---|------|----|------|---|----|----|------|----|-----|----|------|----|----|----|------|----|-----|----|---|----|---|----|--|----|---|----|------|----|----|----|------|----|----|----|------|----|-----|----|------|----|----|----|-----|----|-----|----|-----|----|--------------------------------------|--|--|
| EPI-16 EPID1 Out Inv | If EPID Out Inv is set to 'Yes,' the difference (error) value between the reference and the feedback is set as the feedback-reference value. | | | | | | | | | | | | | | | | | | | | | | | | | | | | | | | | | | | | | | | | | | | | | | | | | | | | | | | | | | | | | | | | | | | | | | | | | | | | | | | | | | | | | | | | |
| EPI-17 EPID1 Unit Sel | <p>Sets the unit for the control variable. 0: CUST is a custom unit defined by the user.</p> <table border="1"> <thead> <tr> <th colspan="4">Setting</th> </tr> </thead> <tbody> <tr> <td>0</td> <td>CUST</td> <td>21</td> <td>m³/m(m³/min)</td> </tr> <tr> <td>1</td> <td>%</td> <td>22</td> <td>m³/h(m³/h)</td> </tr> <tr> <td>2</td> <td>PSI</td> <td>23</td> <td>l/s</td> </tr> <tr> <td>3</td> <td>°F</td> <td>24</td> <td>l/m</td> </tr> <tr> <td>4</td> <td>°C</td> <td>25</td> <td>l/h</td> </tr> <tr> <td>5</td> <td>inWC</td> <td>26</td> <td>kg/s</td> </tr> <tr> <td>6</td> <td>inM</td> <td>27</td> <td>kg/m</td> </tr> <tr> <td>7</td> <td>Bar</td> <td>28</td> <td>kg/h</td> </tr> <tr> <td>8</td> <td>mBar</td> <td>29</td> <td>gl/s</td> </tr> <tr> <td>9</td> <td>Pa</td> <td>30</td> <td>gl/m</td> </tr> <tr> <td>10</td> <td>kPa</td> <td>31</td> <td>gl/h</td> </tr> <tr> <td>11</td> <td>Hz</td> <td>32</td> <td>ft/s</td> </tr> <tr> <td>12</td> <td>Rpm</td> <td>33</td> <td>f³/s(ft³/min)</td> </tr> <tr> <td>13</td> <td>V</td> <td>34</td> <td>f³/h (ft³/h)</td> </tr> <tr> <td>14</td> <td>l</td> <td>35</td> <td>lb/s</td> </tr> <tr> <td>15</td> <td>kW</td> <td>36</td> <td>lb/m</td> </tr> <tr> <td>16</td> <td>HP</td> <td>37</td> <td>lb/m</td> </tr> <tr> <td>17</td> <td>mpm</td> <td>38</td> <td>lb/h</td> </tr> <tr> <td>18</td> <td>ft</td> <td>39</td> <td>ppm</td> </tr> <tr> <td>19</td> <td>m/s</td> <td>40</td> <td>pps</td> </tr> <tr> <td>20</td> <td>m³/s(m³/S)</td> <td></td> <td></td> </tr> </tbody> </table> | Setting | | | | 0 | CUST | 21 | m ³ /m(m ³ /min) | 1 | % | 22 | m ³ /h(m ³ /h) | 2 | PSI | 23 | l/s | 3 | °F | 24 | l/m | 4 | °C | 25 | l/h | 5 | inWC | 26 | kg/s | 6 | inM | 27 | kg/m | 7 | Bar | 28 | kg/h | 8 | mBar | 29 | gl/s | 9 | Pa | 30 | gl/m | 10 | kPa | 31 | gl/h | 11 | Hz | 32 | ft/s | 12 | Rpm | 33 | f ³ /s(ft ³ /min) | 13 | V | 34 | f ³ /h (ft ³ /h) | 14 | l | 35 | lb/s | 15 | kW | 36 | lb/m | 16 | HP | 37 | lb/m | 17 | mpm | 38 | lb/h | 18 | ft | 39 | ppm | 19 | m/s | 40 | pps | 20 | m ³ /s(m ³ /S) | | |
| Setting | | | | | | | | | | | | | | | | | | | | | | | | | | | | | | | | | | | | | | | | | | | | | | | | | | | | | | | | | | | | | | | | | | | | | | | | | | | | | | | | | | | | | | | | | |
| 0 | CUST | 21 | m ³ /m(m ³ /min) | | | | | | | | | | | | | | | | | | | | | | | | | | | | | | | | | | | | | | | | | | | | | | | | | | | | | | | | | | | | | | | | | | | | | | | | | | | | | | | | | | | | | | |
| 1 | % | 22 | m ³ /h(m ³ /h) | | | | | | | | | | | | | | | | | | | | | | | | | | | | | | | | | | | | | | | | | | | | | | | | | | | | | | | | | | | | | | | | | | | | | | | | | | | | | | | | | | | | | | |
| 2 | PSI | 23 | l/s | | | | | | | | | | | | | | | | | | | | | | | | | | | | | | | | | | | | | | | | | | | | | | | | | | | | | | | | | | | | | | | | | | | | | | | | | | | | | | | | | | | | | | |
| 3 | °F | 24 | l/m | | | | | | | | | | | | | | | | | | | | | | | | | | | | | | | | | | | | | | | | | | | | | | | | | | | | | | | | | | | | | | | | | | | | | | | | | | | | | | | | | | | | | | |
| 4 | °C | 25 | l/h | | | | | | | | | | | | | | | | | | | | | | | | | | | | | | | | | | | | | | | | | | | | | | | | | | | | | | | | | | | | | | | | | | | | | | | | | | | | | | | | | | | | | | |
| 5 | inWC | 26 | kg/s | | | | | | | | | | | | | | | | | | | | | | | | | | | | | | | | | | | | | | | | | | | | | | | | | | | | | | | | | | | | | | | | | | | | | | | | | | | | | | | | | | | | | | |
| 6 | inM | 27 | kg/m | | | | | | | | | | | | | | | | | | | | | | | | | | | | | | | | | | | | | | | | | | | | | | | | | | | | | | | | | | | | | | | | | | | | | | | | | | | | | | | | | | | | | | |
| 7 | Bar | 28 | kg/h | | | | | | | | | | | | | | | | | | | | | | | | | | | | | | | | | | | | | | | | | | | | | | | | | | | | | | | | | | | | | | | | | | | | | | | | | | | | | | | | | | | | | | |
| 8 | mBar | 29 | gl/s | | | | | | | | | | | | | | | | | | | | | | | | | | | | | | | | | | | | | | | | | | | | | | | | | | | | | | | | | | | | | | | | | | | | | | | | | | | | | | | | | | | | | | |
| 9 | Pa | 30 | gl/m | | | | | | | | | | | | | | | | | | | | | | | | | | | | | | | | | | | | | | | | | | | | | | | | | | | | | | | | | | | | | | | | | | | | | | | | | | | | | | | | | | | | | | |
| 10 | kPa | 31 | gl/h | | | | | | | | | | | | | | | | | | | | | | | | | | | | | | | | | | | | | | | | | | | | | | | | | | | | | | | | | | | | | | | | | | | | | | | | | | | | | | | | | | | | | | |
| 11 | Hz | 32 | ft/s | | | | | | | | | | | | | | | | | | | | | | | | | | | | | | | | | | | | | | | | | | | | | | | | | | | | | | | | | | | | | | | | | | | | | | | | | | | | | | | | | | | | | | |
| 12 | Rpm | 33 | f ³ /s(ft ³ /min) | | | | | | | | | | | | | | | | | | | | | | | | | | | | | | | | | | | | | | | | | | | | | | | | | | | | | | | | | | | | | | | | | | | | | | | | | | | | | | | | | | | | | | |
| 13 | V | 34 | f ³ /h (ft ³ /h) | | | | | | | | | | | | | | | | | | | | | | | | | | | | | | | | | | | | | | | | | | | | | | | | | | | | | | | | | | | | | | | | | | | | | | | | | | | | | | | | | | | | | | |
| 14 | l | 35 | lb/s | | | | | | | | | | | | | | | | | | | | | | | | | | | | | | | | | | | | | | | | | | | | | | | | | | | | | | | | | | | | | | | | | | | | | | | | | | | | | | | | | | | | | | |
| 15 | kW | 36 | lb/m | | | | | | | | | | | | | | | | | | | | | | | | | | | | | | | | | | | | | | | | | | | | | | | | | | | | | | | | | | | | | | | | | | | | | | | | | | | | | | | | | | | | | | |
| 16 | HP | 37 | lb/m | | | | | | | | | | | | | | | | | | | | | | | | | | | | | | | | | | | | | | | | | | | | | | | | | | | | | | | | | | | | | | | | | | | | | | | | | | | | | | | | | | | | | | |
| 17 | mpm | 38 | lb/h | | | | | | | | | | | | | | | | | | | | | | | | | | | | | | | | | | | | | | | | | | | | | | | | | | | | | | | | | | | | | | | | | | | | | | | | | | | | | | | | | | | | | | |
| 18 | ft | 39 | ppm | | | | | | | | | | | | | | | | | | | | | | | | | | | | | | | | | | | | | | | | | | | | | | | | | | | | | | | | | | | | | | | | | | | | | | | | | | | | | | | | | | | | | | |
| 19 | m/s | 40 | pps | | | | | | | | | | | | | | | | | | | | | | | | | | | | | | | | | | | | | | | | | | | | | | | | | | | | | | | | | | | | | | | | | | | | | | | | | | | | | | | | | | | | | | |
| 20 | m ³ /s(m ³ /S) | | | | | | | | | | | | | | | | | | | | | | | | | | | | | | | | | | | | | | | | | | | | | | | | | | | | | | | | | | | | | | | | | | | | | | | | | | | | | | | | | | | | | | | | |
| EPI-18 EPID1 Unit Scl | Adjusts the scale to fit the unit selected at EPI-17 EPI1 Unit Sel. | | | | | | | | | | | | | | | | | | | | | | | | | | | | | | | | | | | | | | | | | | | | | | | | | | | | | | | | | | | | | | | | | | | | | | | | | | | | | | | | | | | | | | | | |
| EPI-19 EPID1 Unit 0 % EPI-20 EPID1 Unit 100% | Sets the EPID1 Unit 0% value and the EPID1 Unit 100% value as the minimum and maximum values set at EPI1-17. | | | | | | | | | | | | | | | | | | | | | | | | | | | | | | | | | | | | | | | | | | | | | | | | | | | | | | | | | | | | | | | | | | | | | | | | | | | | | | | | | | | | | | | | |

EPID1 Control block

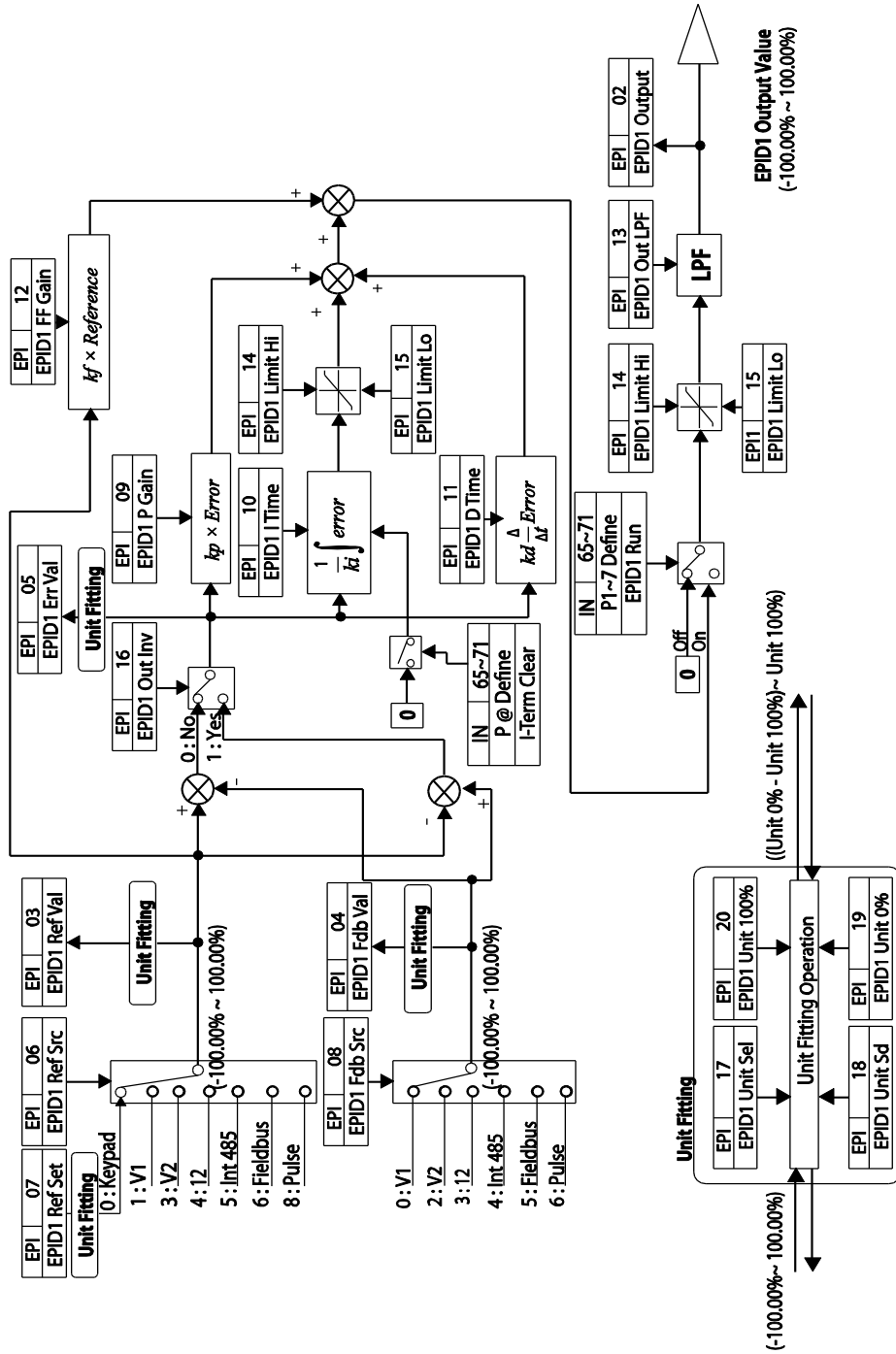

EPID2 Control block

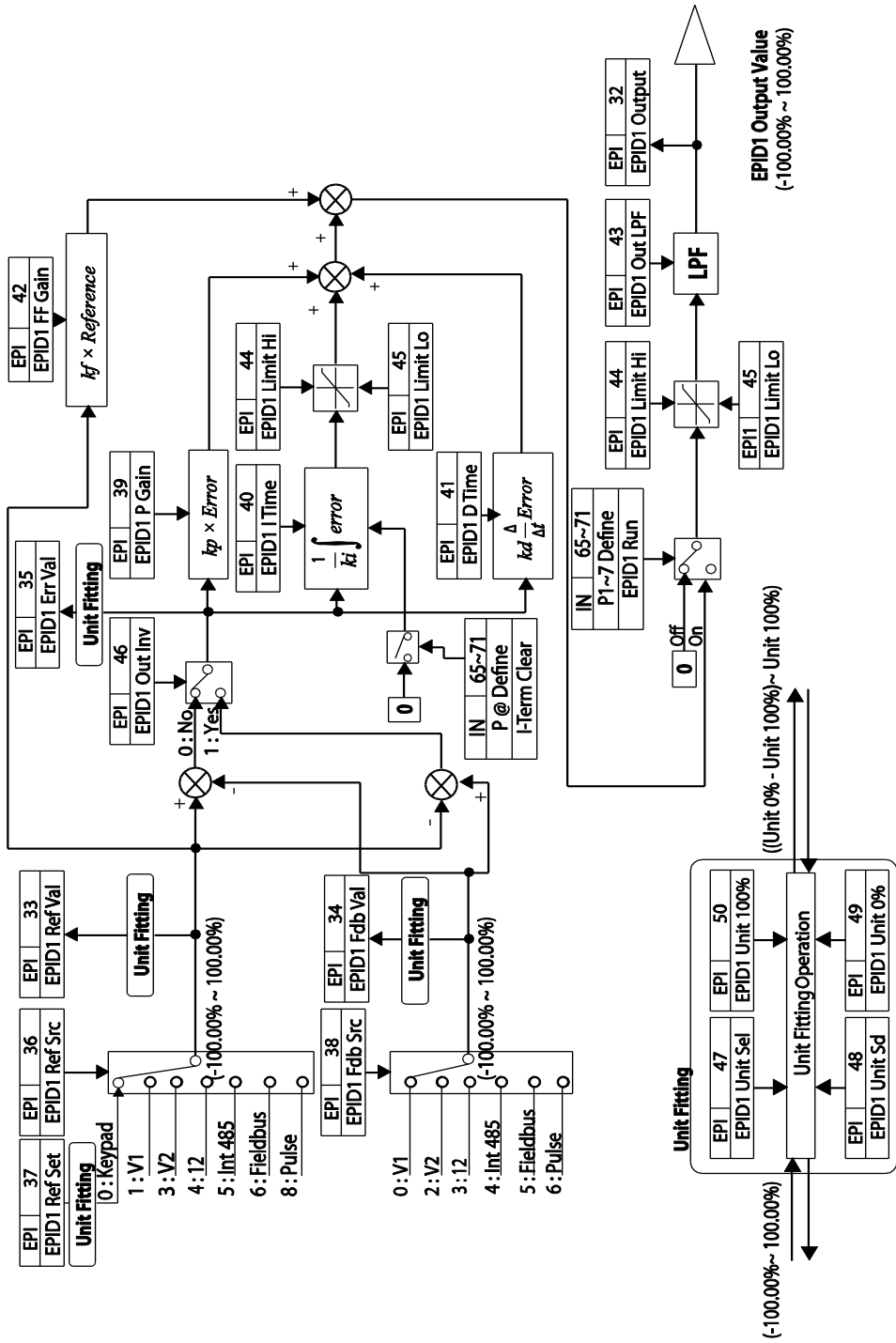

5.10 Damper Operation

A damper is a device that controls the flow in a ventilation system. If a fan and a damper are used together in a system, the inverter may be configured to operate according to the damper's operation status. During a damper operation, one of the relay outputs OUT-31–35 (Relay 1–5) may be set to '33 (Damper Control)' to output a signal based on the damper's operation status. One of the multi-function terminal inputs (IN-65–71) may also be set to '45 (Damper Open)' to receive the damper status input. The inverter starts operating when both the run command and the damper open signal are turned on (relay output setting at OUT-31–35 is not necessary).

When the time difference between the inverter run command and the damper open signal exceeds the delay time set at AP2-45 (Damper DT), damper error (Damper Err) occurs. If the damper open relay output and damper control input are set at the same time, and if the damper open signal is not received until the time set at AP2-45 (Damper DT) is elapsed (when the inverter is not operating), damper error (Damper Err) occurs.

| Group | Code | Name | LCD Display | Parameter Setting | Setting Range | Unit |
|-------|-------|--------------------------------|--------------|---------------------|---------------|------|
| AP2 | 45 | Damper check time | Damper DT | - | 0.1–600.0 | sec |
| IN | 65-71 | P1–7 Px terminal configuration | P1–P7 Define | 45 (Damper open) | - | - |
| OUT | 31-35 | Multi-function relay 1–5 | Relay 1–5 | 33 (Damper Control) | - | - |

Damper Operation Setting Details

| Code | Description |
|----------------------|---|
| AP2-45 Damper DT | Sets the damper open delay time. Detects the inverter run command or the damper open signal (whichever is received first) and outputs a damper error (Damper Err) if the other signal is not received until the time set at AP2-45 elapses. |
| IN-65–71 P1–7 define | Sets one of the multi-functional terminals to '45 (Damper Open)' to enable damper operation. |
| OUT-31–35 Relay 1–5 | Sets one of the relay outputs to '33 (Damper Control)' to provide a relay output when the inverter run command is turned on. |

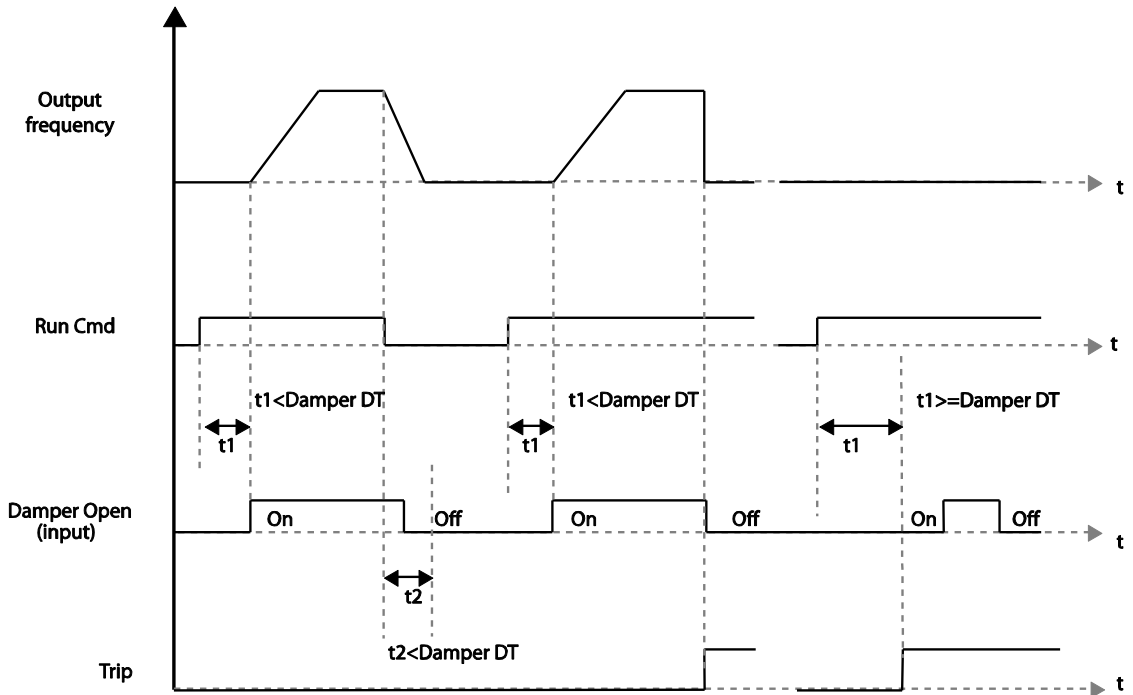

Note

Damper operation is one of the essential system features that are available in both HAND and AUTO modes.

5.11 Lubrication Operation

During a lubrication operation, the inverter outputs the lubrication signal through one of the output relays when the inverter receives a run command. The inverter does not start operating until the time set at AP2-46 (Lub Op Time) has elapsed and the Lubrication signal is turned off.

| Group | Code | Name | LCD Display | Parameter Setting | Setting Range | Unit |
|-------|-------|----------------------------|-------------|---------------------|---------------|-------|
| AP2 | 46 | Lubrication operation time | Lub Op Time | | 0.1–600.0 | (sec) |
| OUT | 31-35 | Multi-function relay 1–5 | Relay 1–5 | 33 (Damper Control) | - | - |

Lubrication Operation Setting Details

| Code | Description |
|---------------------|--|
| AP2-46 Lub Op Time | Outputs the lubrication signal for a set time when the inverter run command is turned on. The inverter starts operating when the set time has elapsed. |
| OUT-31–35 Relay 1–5 | Sets one of the output relays (OUT-31–35) to '30 (Lubrication)' to enable the Lubrication function. |

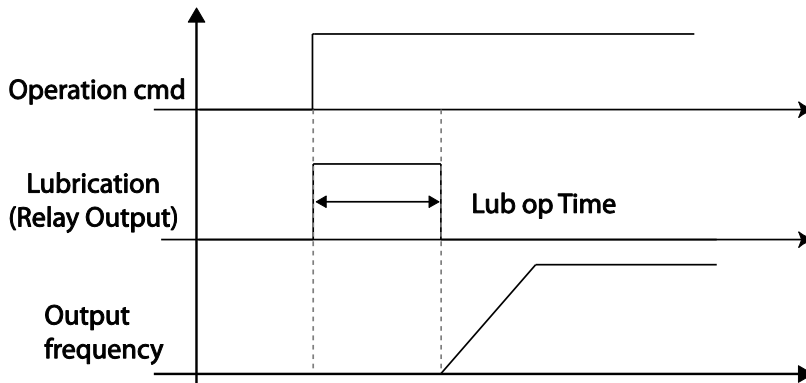

Note

- The lubrication function can be used to delay inverter operations, depending on the working environment, since the inverter waits for the time set at AP2-46 (Lub Op Time) each time a run command is received.
- Lubrication operation is one of the essential system features that are available in both HAND and AUTO modes.

5.12 Flow Compensation

In a system with a pipeline, longer pipes and higher flow rate cause greater pressure loss. A flow compensation operation can compensate for pressure loss by increasing the volume of the PID reference.

| Group | Code | Name | LCD Display | Parameter Setting | Setting Range | | Unit |
|-------|------|----------------------------|----------------|-------------------|---------------|-----|------|
| AP1 | 30 | Flow Comp function options | Flow Comp Sel | - | 0 | No | - |
| | | | | | 1 | Yes | |
| | 31 | Max Comp amount | Max Comp Value | - | 0–Unit Band | | - |

Flow Compensation Setting Details

| Code | Description |
|-----------------------|--|
| AP1-30 Flow Comp Sel | Sets the Flow Compensation function options. |
| AP1-31 Max Comp Value | Sets the maximum compensation volume. This function is based on a PID operation. The volume is given the same unit used for the PID reference. |

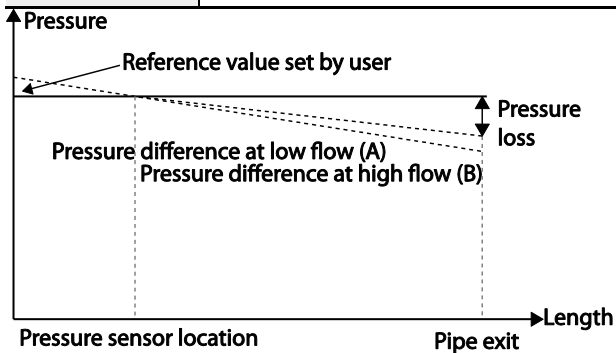

Longer pipes cause the actual pressure to decrease, which in turn increases the difference between the pressure reference and the actual pressure. When the pipe lengths are equal in two different systems, more pressure loss is caused in the system with greater flow. This explains the pressure difference between (A) and (B) in the figure (when the flows are different). To compensate for the pressure loss above, the value of AP1-31 is set to the maximum volume of compensation when the inverter has the maximum frequency, and adds to the PID reference after calculating compensation volume based on the output frequency.

The final PID reference=PID-11+Compensation amount, and compensation amount is shown below.

$$\text{Compensation amount} = \frac{\text{Out Freq} - \text{Start Freq}}{\text{MaxFreq} - \text{Start Freq}} * (\text{PID} - 53) * \frac{(\text{AP1} - 31)}{100\%}$$

PID-53: PID Output Maximum value

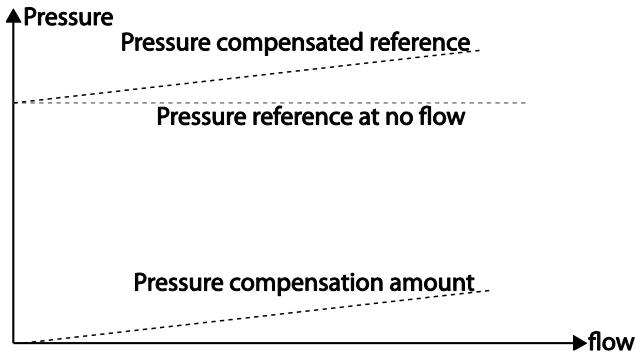

5.13 Payback Counter

The payback counter displays energy savings information by comparing the average energy efficiency for operations with and without the inverter. The energy savings information is displayed as kWh, saved energy cost, and CO2 emission level.

| Group | Code | Name | LCD Display | Parameter Setting | Setting Range | Unit |
|-------|------|-------------------------------------|---------------|-------------------|---------------|------|
| AP2 | 87 | 1 st MOTOR average POWER | M1 AVG PWR | Inverter capacity | 0.1–500.0 | kW |
| | 88 | 2 nd MOTOR average POWER | M2 AVG PWR | Inverter capacity | 0.1–500.0 | kW |
| | 89 | Cost per kWh | Cost per kWh | 0 | 0.0–1000.0 | kW |
| | 90 | Saved kWh | Saved kWh | 0 | -999.9–999.9 | kWh |
| | 91 | Saved MWh | Saved MWh | 0 | -32000–32000 | MWh |
| | 92 | Saved Cost below 1000 unit | Saved Cost1 | 0 | -999.9–999.9 | - |
| | 93 | Saved Cost over 1000 unit | Saved Cost2 | 0 | -32000–32000 | - |
| | 94 | Reduced CO2 conversion Factor | CO2 Factor | 0.5 | 0.1–5.0 | - |
| | 95 | Reduced CO2 (Ton) | Saved CO2 - 1 | 0 | -9999–9999 | Ton |
| | 96 | Reduced CO2 | Saved CO2 - | 0 | -160–160 | Ton |

| Group | Code | Name | LCD Display | Parameter Setting | Setting Range | Unit |
|-------|------|--------------------------------|--------------|-------------------|---------------|------|
| | | (1000 Ton) | 2 | | | |
| | 97 | Reset Energy payback parameter | Reset Energy | 0 | 0 | No |
| | | | | | 1 | Yes |

Energy Payback Value Function Setting Details

| Code | Description |
|--|---|
| AP2-87 M1 AVG PWR | Sets the average power value of the #1 motor and calculates the energy savings based on the set value. |
| AP2-88 M2 AVG PWR | Sets the average power of the #2 motor and calculates energy savings based on the set value. |
| AP2-89 Cost per kWh | Sets the cost per 1 kWh. Multiply the energy payback counter value with the value set at AP2-89 to calculate the total saved cost. This value is displayed in AP2-92–93. |
| AP2-90 Saved kWh AP2-91 Saved MWh | Displays the saved energy in kWh (AP2-90) and MWh (AP2-91). When the value reaches 999.9 (kWh) and continues to increase, AP2-91 becomes 1 (MWh), AP2-90 resets to 0.0, and it continues to increase. |
| AP2-92 Saved Cost1 AP2-93 Saved Cost2 | Displays the saved cost to the one-tenth place at AP2-92. When the value reaches 999.9 and continues to increase, AP2-93 becomes 1, AP2-92 resets to 0.0, and it continues to increase. |
| AP2-94 CO2 Factor | Sets the CO2 reduction rate per 1 MW (default value=0.5). The value is multiplied with AP2-90 and AP2-91, and the resulting values are displayed at AP2-95 and AP2-96. |
| AP2-95 Saved CO2-1 AP2-96 Saved CO2-2 | Displays the CO2 reduction rate in tons (AP2-95) and kilo-tons (AP2-96). |
| AP2-97 Reset Energy | Resets all the saved energy parameters. |

Note

Note that the actual saved energy may differ from the displayed values, since the resulting values are affected by user-defined codes such as AP2-87 and AP2-88.

5.14 Pump Clean Operation

The pump clean operation is used to remove the scales and deposits attached on the impeller inside a pump. This operation keeps the pump clean by performing a repetitive run-

and-stop operation of a pump. This prevents loss in pump performance and premature pump failures.

| Group | Code | Name | LCD Display | Parameter Setting | Setting Range | Unit | |
|-------|----------------------------|---|------------------|-------------------|--------------------------|----------------|-----|
| AP2 | 15 | Pump clean mode 1 | Pump Clean Mode1 | 0: None | 0 | None | - |
| | | | | | 1 | DI Dependent | |
| | | | | | 2 | Output Power | |
| | | | | | 3 | Output Current | |
| | 16 | Pump clean mode 2 | Pump Clean Mode2 | 0: None | 0 | None | - |
| | | | | | 1 | Start | |
| | | | | | 2 | Stop | |
| | | | | | 3 | Start & Stop | |
| | 17 | Pump clean load setting | PC Curve Rate | 100.0 | | 100.0–200.0 | % |
| | 18 | Pump clean reference band | PC Curve Band | 5.0 | | 0.0–100.0 | % |
| | 19 | Pump clean operation delay time | PC Curve DT | 60.0 | | 0–6000.0 | sec |
| | 20 | Pump clean start delay time | PC Start DT | 10.0 | | 0–6000.0 | Sec |
| | 21 | 0 speed operating time at Fx/Rx switching | PC Step DT | 5.0 | | 1.0–6000.0 | Sec |
| 22 | Pump clean Acc time | PC Acc Time | 10.0 | | 0–600.0 | Sec | |
| 23 | Pump clean Dec time | PC Dec Time | 10.0 | | 0–600.0 | Sec | |
| 24 | Forward step run time | Fwd Steady T | 10.0 | | 1.0–6000.0 | Sec | |
| 25 | Forward step run frequency | Fwd SteadyFreq | 30 | | 0.00, Low Freq–High Freq | Hz | |
| 26 | Reverse step run time | Rev Steady T | 10.0 | | 1.0–6000.0 | Sec | |
| 27 | Reverse step run frequency | Rev SteadyFreq | 30 | | 0.00, Low Freq–High Freq | Hz | |

| Group | Code | Name | LCD Display | Parameter Setting | Setting Range | Unit | |
|-------|------------------------------------|--------------------------------------|-----------------|-------------------|---------------|------|---|
| | 28 | Number of Fx/Rx steps for pump clean | PC Num of Steps | 5 | 0-10 | - | |
| | 29 | Pump clean cycle monitoring | Repeat Num Mon | - | - | - | |
| | 30 | Pump clean repeat number | Repeat Num Set | 5 | 0-10 | - | |
| | 31 | Operation after pump clean | PC End Mode | 0 | 0 | Stop | - |
| | | | | | 1 | Run | |
| | 32 | Pump clean continuous time limit | PC Limit Time | 10 | 6-60 | min | |
| 33 | Pump clean continuous number limit | PC Limit Num | 3 | 0-10 | - | | |

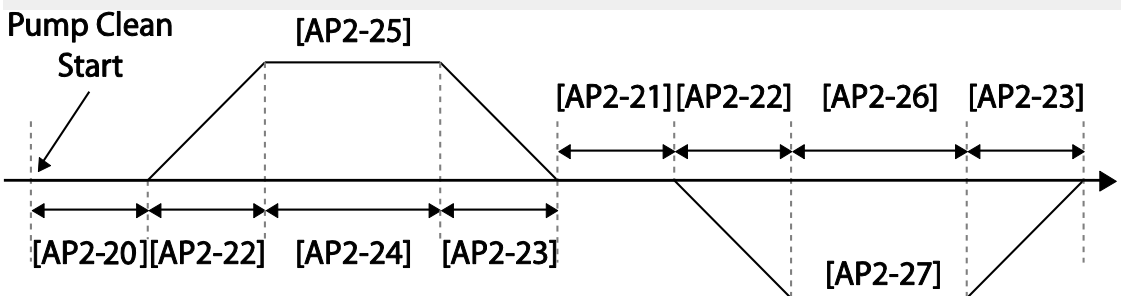

<Basic Pump Clean Operation>

When a pump clean start command is given, the inverter waits until the delay time set at AP2-19 elapses, accelerates by the acceleration time set at AP2-22, and operates at the frequency set at AP2-25. The pump runs for the time set at AP2-24, decelerates by the time set at AP2-23, and then stops. This operation repeats in the forward and reverse directions (one after another) for the number of times set at AP2-28 (PC Num of Step). Each time the steps (Fx/Rx) switch, the inverter waits at a stop state for the time set at AP2-21 before going on with the next step. One step in the forward direction and another step in the reverse direction makes one cycle. The number of pump clean cycles is set at AP2-30. In the figure above, AP2-28 is set to '1', and AP2-30 is set to '1'.

Pump Clean Function Setting Details

| Code | Description | | | | | | | | | | | | | | | |
|--|---|---|---|----------|---|------|---|---|--------------|---|---|-------|---|---|--------------|---|
| AP2-15 PumpClean Mode | Sets the pump mode. | | | | | | | | | | | | | | | |
| | <table border="1"> <thead> <tr> <th data-bbox="454 349 504 382">Setting</th> <th data-bbox="504 349 655 382"></th> <th data-bbox="655 349 1186 382">Function</th> </tr> </thead> <tbody> <tr> <td data-bbox="454 382 504 415">0</td> <td data-bbox="504 382 655 415">None</td> <td data-bbox="655 382 1186 415">Pump Clean function is not used.</td> </tr> <tr> <td data-bbox="454 415 504 511">1</td> <td data-bbox="504 415 655 511">DI defendant</td> <td data-bbox="655 415 1186 511">Set one of the terminal inputs to '46 (Pump Clean Sel)' and performs the pump clean operation by turning on the terminal.</td> </tr> <tr> <td data-bbox="454 511 504 643">2</td> <td data-bbox="504 511 655 643">Power</td> <td data-bbox="655 511 1186 643">Performs a pump clean operation when a pump consumes more power than it is supposed to consume in a normal operation.</td> </tr> <tr> <td data-bbox="454 643 504 774">3</td> <td data-bbox="504 643 655 774">Current</td> <td data-bbox="655 643 1186 774">Performs a pump clean operation when a pump consumes more current than it is supposed to consume in a normal operation.</td> </tr> </tbody> </table> | Setting | | Function | 0 | None | Pump Clean function is not used. | 1 | DI defendant | Set one of the terminal inputs to '46 (Pump Clean Sel)' and performs the pump clean operation by turning on the terminal. | 2 | Power | Performs a pump clean operation when a pump consumes more power than it is supposed to consume in a normal operation. | 3 | Current | Performs a pump clean operation when a pump consumes more current than it is supposed to consume in a normal operation. |
| | Setting | | Function | | | | | | | | | | | | | |
| | 0 | None | Pump Clean function is not used. | | | | | | | | | | | | | |
| | 1 | DI defendant | Set one of the terminal inputs to '46 (Pump Clean Sel)' and performs the pump clean operation by turning on the terminal. | | | | | | | | | | | | | |
| 2 | Power | Performs a pump clean operation when a pump consumes more power than it is supposed to consume in a normal operation. | | | | | | | | | | | | | | |
| 3 | Current | Performs a pump clean operation when a pump consumes more current than it is supposed to consume in a normal operation. | | | | | | | | | | | | | | |
| AP2-16 PumpClean Sel | Sets the pump clean start mode. | | | | | | | | | | | | | | | |
| | <table border="1"> <thead> <tr> <th data-bbox="454 852 504 884">Setting</th> <th data-bbox="504 852 676 884"></th> <th data-bbox="676 852 1186 884">Function</th> </tr> </thead> <tbody> <tr> <td data-bbox="454 884 504 952">0</td> <td data-bbox="504 884 676 952">None</td> <td data-bbox="676 884 1186 952">Pump clean is performed only by the function set at AP2-20.</td> </tr> <tr> <td data-bbox="454 952 504 1020">1</td> <td data-bbox="504 952 676 1020">Start</td> <td data-bbox="676 952 1186 1020">Pump clean is performed each time the inverter starts operating.</td> </tr> <tr> <td data-bbox="454 1020 504 1087">2</td> <td data-bbox="504 1020 676 1087">Stop</td> <td data-bbox="676 1020 1186 1087">Pump clean is performed each time the inverter stops operating.</td> </tr> <tr> <td data-bbox="454 1087 504 1155">3</td> <td data-bbox="504 1087 676 1155">Start & Stop</td> <td data-bbox="676 1087 1186 1155">Pump clean is performed each time the inverter starts or stops operating.</td> </tr> </tbody> </table> | Setting | | Function | 0 | None | Pump clean is performed only by the function set at AP2-20. | 1 | Start | Pump clean is performed each time the inverter starts operating. | 2 | Stop | Pump clean is performed each time the inverter stops operating. | 3 | Start & Stop | Pump clean is performed each time the inverter starts or stops operating. |
| | Setting | | Function | | | | | | | | | | | | | |
| | 0 | None | Pump clean is performed only by the function set at AP2-20. | | | | | | | | | | | | | |
| | 1 | Start | Pump clean is performed each time the inverter starts operating. | | | | | | | | | | | | | |
| 2 | Stop | Pump clean is performed each time the inverter stops operating. | | | | | | | | | | | | | | |
| 3 | Start & Stop | Pump clean is performed each time the inverter starts or stops operating. | | | | | | | | | | | | | | |
| AP2-17 PC Curve Rate AP2-18 PC Curve Band AP2-19 PC Curve DT | <p>If AP2-15 is set to 'Power' or 'Current,' multiply the load characteristic curve set at AP2-2–AP2-10 by the value set at AP2-17 (100[%]+AP2-17[%]), and reset the load characteristic curve for the pump clean operation (refer to the load tune features for AP2-2–AP2-10 setting values).</p> <p>Apply (rated inverter current x AP2-18 setting value) and (rated motor x AP2-18 setting value) to the pump clean load curve calculated by AP2-17 to calculate the final pump clean load curve.</p> <p>The inverter performs pump clean operation when the inverter continues operating for the time set at AP2-19.</p> | | | | | | | | | | | | | | | |
| AP2-20 Clean Start DT | When AP2-15 is set to 'Power' or 'Current', a pump clean is performed if the inverter operation power or current stays above the pump clean load characteristic curve (defined by AP2-17 and AP2-18) for the time set at AP2-19. | | | | | | | | | | | | | | | |
| AP2-21 Clean Step DT | Sets the time for the inverter to maintain 0 speed (stop) before the inverter switches from forward to reverse operation | | | | | | | | | | | | | | | |

| Code | Description | |
|--|--|--|
| | during a pump clean. | |
| AP2-22 PumpClean AccT AP2-23 PumpClean DecT | Sets the Acc/Dec times for pump clean operations. | |
| AP2-24 Fwd Steady Time AP2-26 Rev Steady Time | Sets the time to maintain forward and reverse operations. | |
| AP2-25 Fwd SteadyFreq AP2-27 Rev SteadyFreq | Sets the forward and reverse operation frequencies. | |
| AP2-28 PC Num of Steps | Determines the number of steps (acceleration/deceleration/stop) in one cycle. Each operation, either in the forward or reverse direction, constitutes one step. If set to '2,' one forward step and one reverse step constitute one cycle. | |
| AP2-31 PC End Mode | Determines the inverter operation after pump clean operation. | |
| | Setting | Function |
| | 0 Stop | This stops the inverter after pump cleaning. |
| 1 Start | The inverter operates based on the inverter's command status after the pump cleaning. (If a terminal command is received, the inverter performs the operation it was performing before the pump clean operation.) | |
| AP2-29 Repeat Num Mon | Displays the number of the current pump cleaning cycle. | |
| AP2-30 Repeat Num Set | Sets the number of cycles for one pump clean operation set at AP2-21–AP2-28. | |
| AP2-32 PC Limit Time AP2-33 PC Limit Num | Frequent pump clean operations may indicate a serious system problem. To warn the users of potential system problems, an error (CleanRPTErr) occurs if the number of pump clean operation exceeds the number set at AP2-33 within the time period set at AP2-32. | |

Note

- When the run prevent feature is active and an operation in the prevented direction is required to perform a pump clean operation, the inverter operates at the 0 speed for the time set at AP2-24 and AP2-26 (Steady Time).
- To stop the pump clean operation, press the OFF key on the keypad or turn it off at the terminal input.

- If the pump clean operation is configured for terminal input and it is turned on, and if ADV-10 (PowerOn Resume) is set to 'Yes', a pump clean operation is performed when the inverter is turned on.
- When performing a pump clean operation via terminal input,
 - if the terminal input is turned off instantly after it is turned on (the operation is triggered), 1 pump clean cycle is operated.
 - if ADV-10 (PowerOn Resume) is set to 'Yes', and the terminal input is turned off instantly after it is turned on (the operation is triggered), and if the inverter is turned off during a pump clean then is turned back on again, the pump clean operation is not resumed (because the input terminal is not on when the inverter is turned on).
 - if the terminal input is kept on after it is initially turned on, 1 pump clean cycle is operated.

5.15 Start & End Ramp Operation

This function is used to rapidly accelerate the pump to the normal operating level, or to rapidly decelerate the pump and stop it. Start & End ramp operation is performed when ADV-24 (Freq Limit) is set to '1 (Yes).'

| Group | Code | Name | LCD Display | Parameter Setting | Setting Range | Unit |
|-------|------|---------------------------|----------------|-------------------|---------------------------|------|
| AP2 | 40 | Start & End Ramp Gradient | Start&End Ramp | 0: No | 0 No | - |
| | | | | | 1 Yes | |
| | 41 | StartRampAcc | StartRampAcc | 10.0 | 0-600.0 | Sec |
| | 42 | EndRampDec | EndRampDec | 10.0 | 0-600.0 | Sec |
| ADV | 24 | Frequency limit options | Freq Limit | 0: No | 0 No | - |
| | | | | | 1 Yes | |
| | 25 | Low Freq minimum value | Freq Limit Lo | 30.00 | Start Freq- Max Freq | Hz |
| | 26 | Low Freq maximum value | Freq Limit Hi | 60.00 | Freq Limit Lo-Max Freq | Hz |

Start & End Ramp Operation Setting Details

| Code | Description | | | | |
|-----------------------|---|----------|----------|--------|---|
| AP2-40 Start&End Ramp | Sets the pump Start & End Ramp options. | | | | |
| | <table border="1"> <thead> <tr> <th>Setting</th> <th>Function</th> </tr> </thead> <tbody> <tr> <td>0 No</td> <td>The Start & End Ramp operation is not used.</td> </tr> </tbody> </table> | Setting | Function | 0 No | The Start & End Ramp operation is not used. |
| | Setting | Function | | | |
| 0 No | The Start & End Ramp operation is not used. | | | | |
| | | | | | |

| Code | Description |
|-----------------------|--|
| | 1 Yes Use the Start & End Ramp operation. |
| AP2-41 Start Ramp Acc | Refers to the time it takes to reach the minimum pump operation frequency for a Start & End Ramp operation (Freq Limit Lo) set at ADV-25 when the inverter starts (it is different from DRV-03 acceleration gradient). |
| AP2-42 End Ramp Dec | Refers to the time it takes to reach the 0 step (stop) from the minimum pump operation frequency for a Start & End Ramp operation (Freq Limit Lo) set at ADV-25 (it is different from DRV-03 deceleration gradient). |

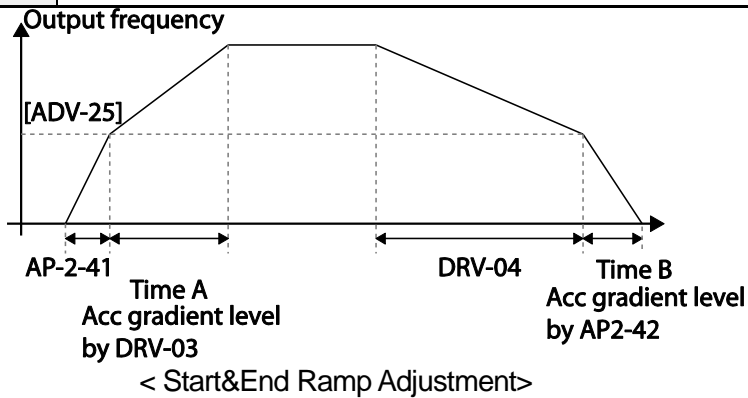

In the figure above, AP2-41 defines the acceleration time to the minimum operation frequency ADV-25 (Freq Limit Lo). AP2-42 defines the deceleration time from the minimum operation frequency to a stopped state. Time A (normal acceleration time set at DRV-03) and Time B (normal deceleration time set at DRV-04) in the figure will change according to the Acc/Dec gradients defined by AP2-41 and AP2-42.

5.16 Decelerating Valve Ramping

| Group | Code | Name | LCD Display | Parameter Setting | Setting Range | Unit |
|-------|------|-----------------------------------|----------------|-------------------|--------------------|------|
| AP2 | 38 | Dec valve ramping start frequency | Dec Valve Freq | 40.00 | Low Freq–High Freq | Hz |
| | 39 | Dec valve ramping time | DecValve Time | 0.0 | 0–6000.0 | Sec |

| | | | | | | |
|-----|----|-------------------------|---------------|-------|------------------------|----|
| ADV | 24 | Frequency limit options | Limit Mode | 0: No | 0 No 1 Yes | - |
| | 25 | Low Freq minimum value | Freq Limit Lo | 30.00 | Start Freq–Max Freq | Hz |
| | 26 | Low Freq maximum value | Freq Limit Hi | 60.00 | Freq Limit Lo–Max Freq | Hz |

This function is used to prevent pump damage due to abrupt deceleration. When the pump operation frequency reaches the valve ramp frequency (AP2-38 Dec Valve Freq) while decelerating rapidly based on the deceleration ramp time (set at AP2-42), it begins to slow down the deceleration based on the deceleration valve ramp time (set at AP2-39 DecValve Time). Decelerating valve ramp operates when ADV-24 (Freq Limit) is set to '1 (Yes)'.

Deceleration Valve Ramping Setting Details

| Code | Description |
|-----------------------|--|
| AP2-38 Dec Valve Freq | Sets the start frequency where the slow deceleration begins in order to prevent pump damage when the inverter stops. Decelerating valve ramping is performed from the frequency set at AP2-38 to the frequency limit set at ADV-25 (low frequency limit for pump operation). |
| AP2-39 DecValve Time | Sets the time it takes to decelerate from the frequency set at AP2-38 to the frequency limit set at ADV-25 (low frequency limit for pump operation). |

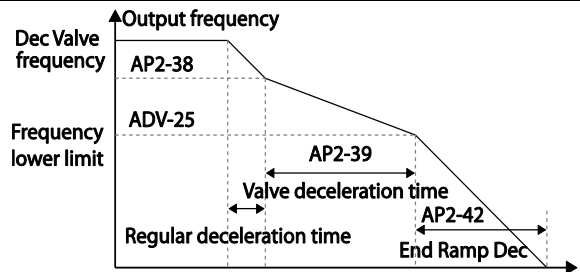

The time set at AP2-39 refers to the absolute time that it takes for the pump to decelerate from the frequency set at AP2-38 to the frequency limit set at ADV-25.

5.17 Load Tuning

Load tuning refers to an operation that detects the load applied to a specific section of the inverter operation (current and voltage) and creates an ideal load curve for the under load and pump clean operations. The two set points to define the section are user-definable, and are set at 50% and 85% of the base frequency (DRV-18 Base Freq) by default. The load tuning result values are saved at codes AP2-2–AP2-10. These values are user definable as

well.

The minimum set point for the load tuning begins at 15% of the base frequency (DRV-18 Base Freq), and the maximum set point can be set up to the base frequency. If the frequency limit is set to '1 (Yes)' at ADV-24 (Freq Limit), the range is limited within the frequencies set at ADV-25 (Freq Limit Lo) and ADV-26 (Freq Limit Hi).

| Group | Code | Name | LCD Display | Parameter Setting | Setting Range | Unit | |
|-------|--------------------------|----------------------------|----------------|-------------------|-------------------------------|------|---|
| AP2 | 01 | Load curve Tuning | Load Tune | No | 0 | No | - |
| | | | | | 1 | Yes | |
| | 02 | Load curve Low Freq | Load Fit LFreq | 30.00 | Base Freq*15%– Load Fit HFreq | Hz | |
| | 03 | Current for Low Freq | Load Fit LCurr | 40.0 | 0.0–200.0 | % | |
| | 04 | Power for Low Freq | Load Fit LPwr | 30.0 | 0.0–200.0 | % | |
| | 08 | Load curve High Freq | Load Fit HFreq | 51.00 | Load Fit LFreq–High Freq | Hz | |
| | 09 | Current for High Freq | Load Fit HCurr | 80.0 | 0.0–200.0 | % | |
| | 10 | Power for High Freq | Load Fit HPwr | 80.0 | 0.0–200.0 | % | |
| | 11 | Load current for frequency | Load Curve Cur | - | - | % | |
| 12 | Load power for frequency | Load Curve Pwr | - | - | % | | |

Load Tuning Setting Details

| Code | Description | | | | | | | | |
|--|--|--------------------------|----------|---|------|--------------------------|---|-----------|--------------------|
| AP2-01 Load Tune | The inverter performs an automatic tuning to generate an ideal system load curve. | | | | | | | | |
| | <table border="1"> <thead> <tr> <th>Setting</th> <th>Function</th> </tr> </thead> <tbody> <tr> <td>0</td> <td>None</td> <td>Load tuning is not used.</td> </tr> <tr> <td>1</td> <td>Load Tune</td> <td>Start load tuning.</td> </tr> </tbody> </table> | Setting | Function | 0 | None | Load tuning is not used. | 1 | Load Tune | Start load tuning. |
| | Setting | Function | | | | | | | |
| 0 | None | Load tuning is not used. | | | | | | | |
| 1 | Load Tune | Start load tuning. | | | | | | | |
| | | | | | | | | | |
| AP2-02 Load Fit LFreq | Defines the first frequency set point for load tuning (user definable). | | | | | | | | |
| AP2-03 Load Fit LCurr AP2-04 Load Fit LPwr | Displays the current and power measured at the frequency set at AP2-02 as a percentage (%) value, based on motor rated current and rated power. Values for AP2-03 and AP2-04 are user definable. | | | | | | | | |
| AP2-08 Load fit HFreq | Defines the second frequency set point for load tuning(user definable). | | | | | | | | |
| AP2-09 Load Fit HCurr AP2-10 Load Fit HPwr | Displays the current and power measured at the frequency set at AP2-08 as a percentage (%) value, based on motor rated current and rated power. Values for AP2-09 and AP2-10 are user definable. | | | | | | | | |
| AP2-11 Load Curve Cur AP2-12 Load Curve PWR | Monitors the load curve value set at AP2-1 (Load Tune) based on the current output frequency. | | | | | | | | |

When a load tuning is performed, the inverter measures for 10 seconds the motor current and power, at the frequencies set at AP2-02 and AP2-09. The motor current and power values measured here are used to generate an ideal load curve.

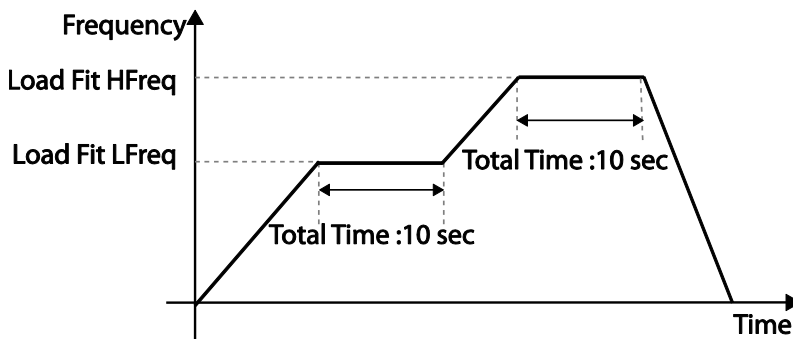

Note

Load tuning is not available while the inverter is operating.

⚠ Caution

- If the frequencies for AP2-02 (Low Freq) and AP2-08 (High Freq) are set too close to each other, the resulting load curve may not reflect the actual (ideal) load curve. Therefore, it is recommended that you keep the AP2-02 and AP2-08 frequencies as close to the factory defaults as possible.
- If a secondary motor is in use, note that the existing load curve for the main motor will be applied to the secondary motor unless a load tuning has been performed for the secondary motor.

5.18 Level Detection

When the inverter is operating at or above the frequency set at PRT-74 (LDT Level), this function is used to triggers a fault trip or sets a relay output if the source value is out of the range of the user-defined values. If the reset restart feature is turned on, the inverter continues to operate based on the run command after the LDT fault trip is released.

| Group | Code | Name | LCD Display | Parameter Setting | Setting Range | Unit |
|-------|------|-----------------------------------|----------------|------------------------|------------------------|------|
| PRT | 70 | Level detection mode | LDT Sel | Warning | None/Warning/Trip | |
| | 71 | Level detection range | LDT Area Sel | 1 . Above Level | 0–1 | - |
| | 72 | Level detection source | LDT Source | 0: Output Current | 0–12 | - |
| | 73 | Level detection delay time | LDT Dly Time | 2.0 | 0–9999 | Sec |
| | 74 | Level detection reference value | LDT Level | Source setting is used | Source setting is used | - |
| | 75 | Level detection bandwidth | LDT Band width | Source setting is used | Source setting is used | - |
| | 76 | Level detection frequency | LDT Freq | 20.00 | 0.00–Max Freq (Hz) | Hz |
| | 77 | Level detection trip restart time | LDT Restart DT | 60.0 | 0.0–3000.0 | Min |
| | 96 | LDT Auto restart count | LDT Rst Cnt | 1 | 0–6000 | - |
| | 97 | LDT Auto restart cycle count | LDT Rst Cnt M | - | 0–6000 | - |

| Group | Code | Name | LCD Display | Parameter Setting | Setting Range | Unit |
|-------|------|--|---------------|-------------------|---------------|------|
| | 98 | LDT Auto restart cycle Initialization time | LDT Cnt Clr T | 60 | 0~6000 | Sec |

Level Detection Setting Details

| Code | Description | | | | | | | | | | | | | | | | | | | | | | | | | | | | |
|---------------------|---|--|-----------|---|---|---|---|---|--|---|--|---|--|---|---|---|---|---|---|---|--|---|---|----|--|----|--|----|--|
| PRT-70 LDT Sel | Determines the inverter operation when a level detection trip occurs. | | | | | | | | | | | | | | | | | | | | | | | | | | | | |
| | <table border="1"> <thead> <tr> <th>Setting</th> <th>Functions</th> </tr> </thead> <tbody> <tr> <td>0</td> <td>None No operation</td> </tr> <tr> <td>1</td> <td>Warning The inverter displays a warning message.</td> </tr> <tr> <td>2</td> <td>Free-Run The inverter free-runs, then stops.</td> </tr> <tr> <td>3</td> <td>Dec The inverter decelerates, then stops.</td> </tr> </tbody> </table> | Setting | Functions | 0 | None No operation | 1 | Warning The inverter displays a warning message. | 2 | Free-Run The inverter free-runs, then stops. | 3 | Dec The inverter decelerates, then stops. | | | | | | | | | | | | | | | | | | |
| | Setting | Functions | | | | | | | | | | | | | | | | | | | | | | | | | | | |
| | 0 | None No operation | | | | | | | | | | | | | | | | | | | | | | | | | | | |
| | 1 | Warning The inverter displays a warning message. | | | | | | | | | | | | | | | | | | | | | | | | | | | |
| 2 | Free-Run The inverter free-runs, then stops. | | | | | | | | | | | | | | | | | | | | | | | | | | | | |
| 3 | Dec The inverter decelerates, then stops. | | | | | | | | | | | | | | | | | | | | | | | | | | | | |
| PRT-71 Level Detect | Sets the level detection range. | | | | | | | | | | | | | | | | | | | | | | | | | | | | |
| | <table border="1"> <thead> <tr> <th>Setting</th> <th>Operation</th> </tr> </thead> <tbody> <tr> <td>1</td> <td>Below Triggers a level detect fault trip when the inverter operates below the frequency set by the user.</td> </tr> <tr> <td>2</td> <td>Above Triggers a level detect fault trip when the inverter operates above the frequency set by the user.</td> </tr> </tbody> </table> | Setting | Operation | 1 | Below Triggers a level detect fault trip when the inverter operates below the frequency set by the user. | 2 | Above Triggers a level detect fault trip when the inverter operates above the frequency set by the user. | | | | | | | | | | | | | | | | | | | | | | |
| | Setting | Operation | | | | | | | | | | | | | | | | | | | | | | | | | | | |
| 1 | Below Triggers a level detect fault trip when the inverter operates below the frequency set by the user. | | | | | | | | | | | | | | | | | | | | | | | | | | | | |
| 2 | Above Triggers a level detect fault trip when the inverter operates above the frequency set by the user. | | | | | | | | | | | | | | | | | | | | | | | | | | | | |
| PRT-72 LDT Source | Selects a source for level detection. | | | | | | | | | | | | | | | | | | | | | | | | | | | | |
| | <table border="1"> <thead> <tr> <th>Setting</th> <th>Function</th> </tr> </thead> <tbody> <tr> <td>0</td> <td>Output Current Sets the output current as the source.</td> </tr> <tr> <td>1</td> <td>DC Link Voltage Sets the DC link voltage as the source.</td> </tr> <tr> <td>2</td> <td>Output Voltage Sets the output voltage as the source.</td> </tr> <tr> <td>3</td> <td>kW Sets the output power as the source.</td> </tr> <tr> <td>4</td> <td>hp Sets the output power as the source.</td> </tr> <tr> <td>5</td> <td>V1 Sets the V1 terminal input as the source.</td> </tr> <tr> <td>6</td> <td>V2 Sets the V2 terminal input as the source.</td> </tr> <tr> <td>7</td> <td>I2 Sets the I2 terminal input as the source.</td> </tr> <tr> <td>8</td> <td>PID Ref Value Sets the PID reference as the source.</td> </tr> <tr> <td>9</td> <td>PID Fdb Val Sets the PID feedback as the source.</td> </tr> <tr> <td>10</td> <td>PID Output Sets the PID output as the source.</td> </tr> <tr> <td>11</td> <td>EPID1 Fdb Val Sets the external PID feedback 1 as the source.</td> </tr> <tr> <td>12</td> <td>EPID2 Fdb Val Sets the external PID feedback 2 as the source.</td> </tr> </tbody> </table> | Setting | Function | 0 | Output Current Sets the output current as the source. | 1 | DC Link Voltage Sets the DC link voltage as the source. | 2 | Output Voltage Sets the output voltage as the source. | 3 | kW Sets the output power as the source. | 4 | hp Sets the output power as the source. | 5 | V1 Sets the V1 terminal input as the source. | 6 | V2 Sets the V2 terminal input as the source. | 7 | I2 Sets the I2 terminal input as the source. | 8 | PID Ref Value Sets the PID reference as the source. | 9 | PID Fdb Val Sets the PID feedback as the source. | 10 | PID Output Sets the PID output as the source. | 11 | EPID1 Fdb Val Sets the external PID feedback 1 as the source. | 12 | EPID2 Fdb Val Sets the external PID feedback 2 as the source. |
| | Setting | Function | | | | | | | | | | | | | | | | | | | | | | | | | | | |
| | 0 | Output Current Sets the output current as the source. | | | | | | | | | | | | | | | | | | | | | | | | | | | |
| | 1 | DC Link Voltage Sets the DC link voltage as the source. | | | | | | | | | | | | | | | | | | | | | | | | | | | |
| | 2 | Output Voltage Sets the output voltage as the source. | | | | | | | | | | | | | | | | | | | | | | | | | | | |
| | 3 | kW Sets the output power as the source. | | | | | | | | | | | | | | | | | | | | | | | | | | | |
| | 4 | hp Sets the output power as the source. | | | | | | | | | | | | | | | | | | | | | | | | | | | |
| | 5 | V1 Sets the V1 terminal input as the source. | | | | | | | | | | | | | | | | | | | | | | | | | | | |
| | 6 | V2 Sets the V2 terminal input as the source. | | | | | | | | | | | | | | | | | | | | | | | | | | | |
| | 7 | I2 Sets the I2 terminal input as the source. | | | | | | | | | | | | | | | | | | | | | | | | | | | |
| | 8 | PID Ref Value Sets the PID reference as the source. | | | | | | | | | | | | | | | | | | | | | | | | | | | |
| | 9 | PID Fdb Val Sets the PID feedback as the source. | | | | | | | | | | | | | | | | | | | | | | | | | | | |
| 10 | PID Output Sets the PID output as the source. | | | | | | | | | | | | | | | | | | | | | | | | | | | | |
| 11 | EPID1 Fdb Val Sets the external PID feedback 1 as the source. | | | | | | | | | | | | | | | | | | | | | | | | | | | | |
| 12 | EPID2 Fdb Val Sets the external PID feedback 2 as the source. | | | | | | | | | | | | | | | | | | | | | | | | | | | | |

| Code | Description | | | | | | | | | | | | | | | | | | | | | | | | | | | | | | | | | | | | | | | |
|-----------------------|---|---------------------------------|--------------------------------------|---------------|----------------|---------------|-----------------------------|-----------------|------------|--------------------------------------|----------------|------------|----------------------------------|----|---------------------------------|------------------------------------|----|--------|------------|----|------|--------------|----|-------|------------|---------------|----|---------------------------|-------------|----|---------------------------|------------|----|------------------|---------------|----|-------------------------------|---------------|----|-------------------------------|
| PRT-73 LDT Dly Time | Sets the delay time for the operation set at PRT-70. | | | | | | | | | | | | | | | | | | | | | | | | | | | | | | | | | | | | | | | |
| PRT-74 LDT Level | <p>Sets the level for the level detection. The following are the setting ranges and default values by the source.</p> <table border="1"> <thead> <tr> <th>Source</th> <th>Default Value</th> <th>Setting Range</th> </tr> </thead> <tbody> <tr> <td>Output Current</td> <td>Rated current</td> <td>0–150% of the rated current</td> </tr> <tr> <td>DC Link Voltage</td> <td>350 700</td> <td>0–450 V (2 Type) 0–900 V (4 Type)</td> </tr> <tr> <td>Output Voltage</td> <td>230 460</td> <td>0–250 (2 Type) 0–500 (4 Type)</td> </tr> <tr> <td>kW</td> <td>90% of the Inverter rated power</td> <td>0–150% of the Inverter rated power</td> </tr> <tr> <td>V1</td> <td>9.00 V</td> <td>0.00–12.00</td> </tr> <tr> <td>V2</td> <td>9.00</td> <td>-12.00–12.00</td> </tr> <tr> <td>I2</td> <td>18.00</td> <td>0.00–25.00</td> </tr> <tr> <td>PID Ref Value</td> <td>50</td> <td>PID Unit Min–PID Unit Max</td> </tr> <tr> <td>PID Fdb Val</td> <td>50</td> <td>PID Unit Min–PID Unit Max</td> </tr> <tr> <td>PID Output</td> <td>50</td> <td>-100.00%–100.00%</td> </tr> <tr> <td>EPID1 Fdb Val</td> <td>50</td> <td>EPID1 Unit Min–EPID1 Unit Max</td> </tr> <tr> <td>EPID2 Fdb Val</td> <td>50</td> <td>EPID2 Unit Min–EPID2 Unit Max</td> </tr> </tbody> </table> | Source | Default Value | Setting Range | Output Current | Rated current | 0–150% of the rated current | DC Link Voltage | 350 700 | 0–450 V (2 Type) 0–900 V (4 Type) | Output Voltage | 230 460 | 0–250 (2 Type) 0–500 (4 Type) | kW | 90% of the Inverter rated power | 0–150% of the Inverter rated power | V1 | 9.00 V | 0.00–12.00 | V2 | 9.00 | -12.00–12.00 | I2 | 18.00 | 0.00–25.00 | PID Ref Value | 50 | PID Unit Min–PID Unit Max | PID Fdb Val | 50 | PID Unit Min–PID Unit Max | PID Output | 50 | -100.00%–100.00% | EPID1 Fdb Val | 50 | EPID1 Unit Min–EPID1 Unit Max | EPID2 Fdb Val | 50 | EPID2 Unit Min–EPID2 Unit Max |
| | Source | Default Value | Setting Range | | | | | | | | | | | | | | | | | | | | | | | | | | | | | | | | | | | | | |
| | Output Current | Rated current | 0–150% of the rated current | | | | | | | | | | | | | | | | | | | | | | | | | | | | | | | | | | | | | |
| | DC Link Voltage | 350 700 | 0–450 V (2 Type) 0–900 V (4 Type) | | | | | | | | | | | | | | | | | | | | | | | | | | | | | | | | | | | | | |
| | Output Voltage | 230 460 | 0–250 (2 Type) 0–500 (4 Type) | | | | | | | | | | | | | | | | | | | | | | | | | | | | | | | | | | | | | |
| | kW | 90% of the Inverter rated power | 0–150% of the Inverter rated power | | | | | | | | | | | | | | | | | | | | | | | | | | | | | | | | | | | | | |
| | V1 | 9.00 V | 0.00–12.00 | | | | | | | | | | | | | | | | | | | | | | | | | | | | | | | | | | | | | |
| | V2 | 9.00 | -12.00–12.00 | | | | | | | | | | | | | | | | | | | | | | | | | | | | | | | | | | | | | |
| | I2 | 18.00 | 0.00–25.00 | | | | | | | | | | | | | | | | | | | | | | | | | | | | | | | | | | | | | |
| | PID Ref Value | 50 | PID Unit Min–PID Unit Max | | | | | | | | | | | | | | | | | | | | | | | | | | | | | | | | | | | | | |
| | PID Fdb Val | 50 | PID Unit Min–PID Unit Max | | | | | | | | | | | | | | | | | | | | | | | | | | | | | | | | | | | | | |
| | PID Output | 50 | -100.00%–100.00% | | | | | | | | | | | | | | | | | | | | | | | | | | | | | | | | | | | | | |
| | EPID1 Fdb Val | 50 | EPID1 Unit Min–EPID1 Unit Max | | | | | | | | | | | | | | | | | | | | | | | | | | | | | | | | | | | | | |
| EPID2 Fdb Val | 50 | EPID2 Unit Min–EPID2 Unit Max | | | | | | | | | | | | | | | | | | | | | | | | | | | | | | | | | | | | | | |
| PRT-75 LDT Band Width | <p>If the source is detected below the set level, it must be adjusted to be above the 'LDT Level + LDT Band Width' value to release the level detection fault trip. If the source is detected above the set level, it must be adjusted to be below the 'LDT Level - LDT Band Width' value to release the level detection fault trip. The level detection trip bandwidth is 10% of the maximum source value.</p> | | | | | | | | | | | | | | | | | | | | | | | | | | | | | | | | | | | | | | | |
| PRT-76 LDT Freq | Sets the start frequency for the level detection. When setting the level detection frequency, take into consideration the source type and the LDT level. | | | | | | | | | | | | | | | | | | | | | | | | | | | | | | | | | | | | | | | |
| PRT-77 LDT Restart DT | <p>If PRT-08 (RST restart) is set to 'YES,' the inverter restarts after the time set at PRT-76 elapses when an LDT trip is released. The LDT Restart operates each time an LDT trip is released. If PRT-77 is set to any other value than '0' and the inverter is operating in HAND mode, the inverter resets and the LDT trip is released. However, the inverter stays in OFF mode and does not restart the operation instantly.</p> | | | | | | | | | | | | | | | | | | | | | | | | | | | | | | | | | | | | | | | |

| Code | Description |
|--|---|
| PRT-96 LDT Rst Cnt PRT-97 LDT Rst Cnt M PRT-98 LDT Cnt Clr T | When the LDT trip occurs, the number of automatic restart is set by PRT-96. If an LDT trip occurs, the inverter automatically restarts after the time set in PRT-77 (LDT Restart DT) has elapsed. The PRT-97 is incremented by 1 each time it is automatically restarted. When the value of PRT-97 becomes equal to PRT-96, it does not try to restart automatically. The LDT trip will be restarted within the time set in PRT-98 after auto restart If not, PRT-97 is initialized to 0. |
| OUT-31-35 Relay 1-5 | Sets one of the output relays to '32 (LDT)' to monitor the level detection status. |

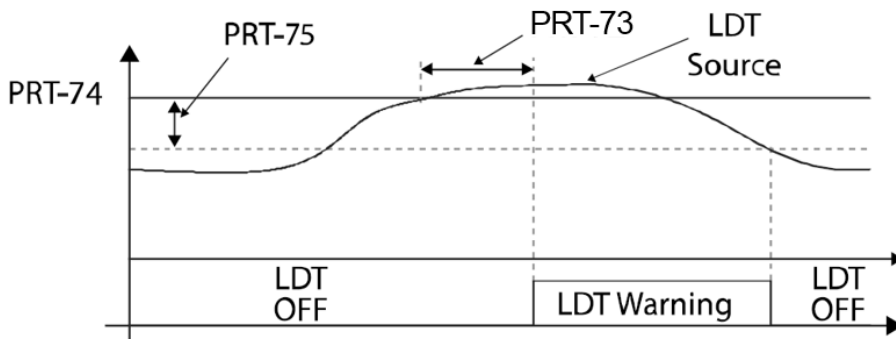

<An example of PRT-71 set to (1: Above Level) >

As shown in the figure above, level detection can be carried out (relay output is 'on') as the output frequency is above PRT-76 and the detection value is greater than the value of PRT-74. The LDT operation is released if the value is less than the value subtracted from the value of band of, when the value of the feedback is set from PRT-74 to PRT-75.

⚠ Caution

- The LDT operation is carried out if the inverter operation is above PRT-74.
- Modify PRT-74 and PRT-75 appropriately when modifying LDT Source of PRT-71.
- PRT-74 and PRT-75 become default value if the LDT Source is modified.
- PRT-77 (Restart DT) and PRT-08 (RST restart) features operate separately.
- The inverter waits until the delay time set at PRT-73 (LDT Dly Time) before it operates based on the setting in LDT-70 when the level detection time condition is met.

5.19 Pipe Break Detection

This function detects Pipe Breaks while the PID operation is on. The fault trip or a warning signal will occur if the feedback does not reach the level set by users during the operation with the maximum output (PID maximum output or the maximum speed set).

| Group | Code | Name | LCD Display | Parameter Setting | Setting Range | Unit |
|-------|-------|--------------------------------|----------------|-------------------|---------------|----------|
| PRT | 60 | Pipe Break Detection setting | PipeBroken Sel | 0 | 0 | None |
| | | | | | 1 | Warning |
| | | | | | 2 | Free-Run |
| | | | | | 3 | Dec |
| | 61 | Pipe Break Detection variation | PipeBroken Dev | 97.5 | 0–100 | % |
| | 62 | Pipe Break Detection time | PipeBroken DT | 10.0 | 0–6000.0 | Sec |
| OUT | 31–36 | Relay output 1–5 | Relay1–5 | 28 | Pipe Broken | - |

Pipe Break Detection Details

| Code | Description | | | | | | | | | | | | | | |
|--------------------------|---|---------------------------------------|--|---|------|--------------|---|---------|--|---|----------|-------------------------------------|---|-----|---------------------------------------|
| PRT-60 PipeBroken Sel | Select the operation while detecting Pipe Breaks | | | | | | | | | | | | | | |
| | <table border="1"> <thead> <tr> <th>Setting</th> <th>Function</th> </tr> </thead> <tbody> <tr> <td>0</td> <td>None</td> <td>No operation</td> </tr> <tr> <td>1</td> <td>Warning</td> <td>The inverter displays a warning message.</td> </tr> <tr> <td>2</td> <td>Free-Run</td> <td>The inverter free-runs, then stops.</td> </tr> <tr> <td>3</td> <td>Dec</td> <td>The inverter decelerates, then stops.</td> </tr> </tbody> </table> | Setting | Function | 0 | None | No operation | 1 | Warning | The inverter displays a warning message. | 2 | Free-Run | The inverter free-runs, then stops. | 3 | Dec | The inverter decelerates, then stops. |
| | Setting | Function | | | | | | | | | | | | | |
| | 0 | None | No operation | | | | | | | | | | | | |
| | 1 | Warning | The inverter displays a warning message. | | | | | | | | | | | | |
| 2 | Free-Run | The inverter free-runs, then stops. | | | | | | | | | | | | | |
| 3 | Dec | The inverter decelerates, then stops. | | | | | | | | | | | | | |
| PRT-61 PipeBroken Dev | Sets the Pipe Break Detection level. Set the detect level by multiplying the set value for PRT-61 by PID Reference. | | | | | | | | | | | | | | |
| PRT-62 PipeBroken DT | Sets the detect delay time. Pipe Break operates if the Pipe Break situation is maintained for a set amount of time. | | | | | | | | | | | | | | |
| OUT31–36 Define | If Pipe Break (28) is set, when a Pipe Break occurs, the inverter sends out output with Relay. | | | | | | | | | | | | | | |

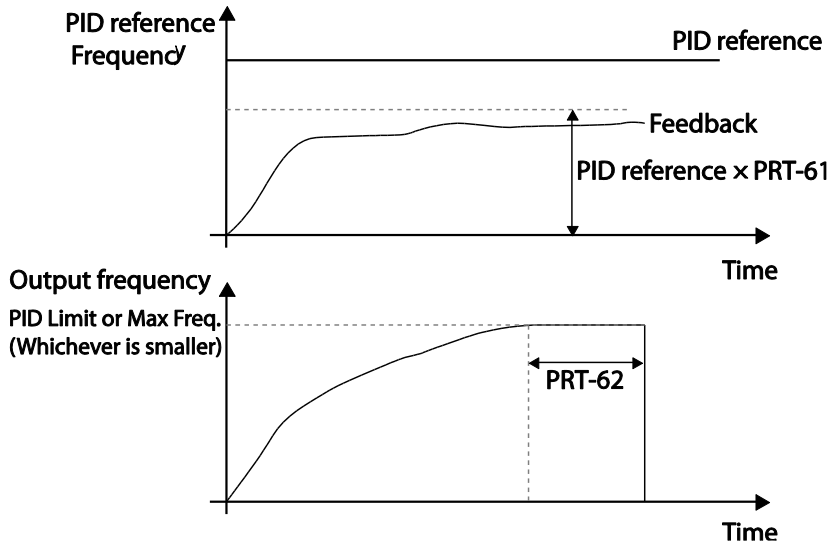

In the graph above, Pipe Break occurs if the feedback is smaller than the value calculated by multiplying the two values set at PID-04 and PRT-61(PID-04 x PRT-61) at the inverter's maximum output (when PID output is the maximum set value, or the inverter is running at the frequency set at DRV-20).

5.20 Pre-heating Function

This function uses current to heat up the motor or pump to avoid the motor or the pump freezing when they are not in operation.

| Group | Code | Name | LCD Display | Parameter Setting | Setting Range | Unit |
|-------|-------|--------------------------------|----------------|-------------------|---------------|------|
| AP2 | 48 | Initial heating output current | Pre Heat Level | 20 | 1–100 | % |
| | 49 | Initial heating output duty | Pre Heat Duty | 30 | 1–100 | % |
| | 50 | DC input delay time | DC Inj Delay T | 60.0 | 0.0–600.0 | sec |
| IN | 65–71 | Terminal block input 1–7 | P1–7 Define | 44 | Pre Heat | - |

Initial Heating Setting Details

| Code | Description |
|-----------------------|--|
| AP2-48 Pre Heat Curr | Sets the current to be used for initial heating. Sets the current to motor no-load current % value. |
| AP2-49 Pre Heat Duty | Sets the duty (time) for the current to be used for initial heating, from 10 seconds to % value. |
| AP2-50 DC Inj Delay T | Sets a certain delay time to prevent from an over current trip that may occur when a DC input is performed after the inverter Free-Run stop. |
| IN-65–71 P1–7 Define | Performs the Pre Heat function if the Pre Heat (44) terminal is set. |

The initial heating function continually operates when the set multi-function input terminal is on and until the inverter command is on. If an inverter command is input while the initial heating function is operating, the inverter starts operation immediately.

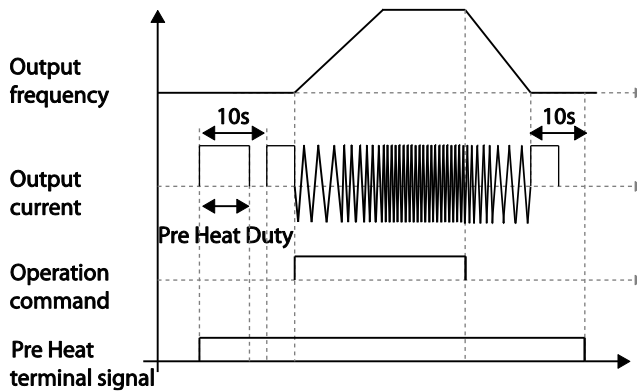

The initial heating operation starts to run after an inverter operation stops, when the initial heating function's terminal input is on after the inverter operation command is off.

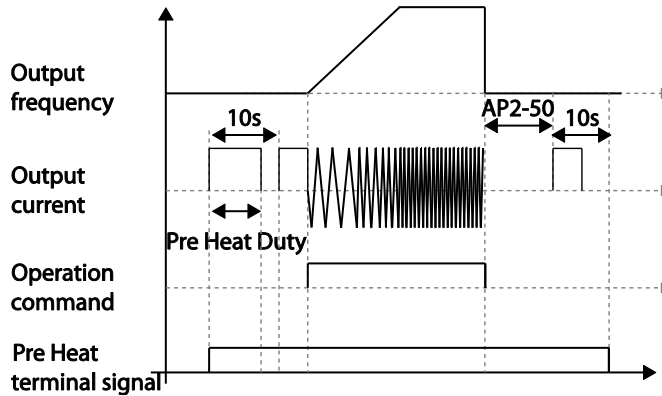

The diagram above shows the operation waveform related to AP2-50 DC Inj Delay T. The Pre Heat function performs when the inverter stop mode is set to Free Run and the Pre Heat signal is supplied. Then, if the inverter operation command is on, the inverter maintains acceleration and a fixed frequency. If the inverter operation command is off, the motor is in Free Run and the Pre Heat operations starts after the time amount set in AP2-50.

⚠ Caution

- If the value for AP2-48 Pre Heat Curr is above the rated motor current value, it is limited by the rated motor current value.
- If the value for AP2-48 Pre Heat Curr is too high or the DC current output time is too long, the motor may overheat or be damaged and the Inver IOLT may also malfunction. Reduce the DC output current amount and DC output time to prevent from such damages.

5.21 Auto Tuning

The motor parameters can be measured automatically and can be used for an auto torque boost.

Example - Auto Tuning Based on 5.5 kW, 200 V Motor

| Group | Code | Name | LCD Display | Parameter Setting | | Setting Range | Unit |
|-------|--------------------|-----------------------|----------------|-------------------|------------------------------|------------------------------|----------|
| DRV | 14 | Motor capacity | Motor Capacity | 9 | 5.5 kW | 7–20 | - |
| BAS | 11 | Motor pole number | Pole Number | 4 | | 2–48 | - |
| | 12 | Rated slip speed | Rated Slip | 45 | | 0–3000 | Rpm |
| | 13 | Rated motor current | Rated Curr | 21.0 | | 1.0–1000.0 | A |
| | 14 | Motor no-load current | Noload curr | 7.1 | | 0.5–1000.0 | A |
| | 15 | Motor rated voltage | Rated Volt | 220 | | 170–480 | V |
| | 16 | Motor efficiency | Efficiency | 85 | | 70–100 | % |
| | 20 | Auto tuning | Auto Tuning | 0 | None | - | - |
| | 21 | Stator resistance | Rs | 0.314 | | Depends on the motor setting | Ω |
| 22 | Leakage inductance | Lsigma | 3.19 | | Depends on the motor setting | mH | |

Auto Tuning Default Parameter Setting

| Motor Capacity (kW) | Rated Current (A) | No-load Current (A) | Rated Slip Frequency (Hz) | Stator Resistance (Ω) | Leakage Inductance (mH) | |
|---------------------|-------------------|---------------------|---------------------------|--------------------------------|-------------------------|-------|
| 200 V | 0.75 | 3.4 | 1.7 | 3.00 | 2.60 | 17.94 |
| | 1.5 | 6.4 | 2.6 | 2.67 | 1.17 | 2.29 |
| | 2.2 | 8.6 | 3.3 | 2.3 | 0.84 | 6.63 |
| | 3.7 | 13.8 | 5.0 | 2.3 | 0.50 | 4.48 |
| | 5.5 | 21.0 | 7.1 | 1.50 | 0.314 | 3.19 |
| | 7.5 | 28.2 | 9.3 | 1.33 | 0.169 | 2.844 |
| | 11 | 40.0 | 12.4 | 1.00 | 0.120 | 1.488 |
| | 15 | 53.6 | 15.5 | 1.00 | 0.084 | 1.118 |
| | 18.5 | 65.6 | 19.0 | 1.00 | 0.0676 | 0.819 |
| 400 V | 0.75 | 2.0 | 1.0 | 3.00 | 7.81 | 53.9 |
| | 1.5 | 3.7 | 1.5 | 2.67 | 3.52 | 27.9 |
| | 2.2 | 5.0 | 1.9 | 2.3 | 2.52 | 19.95 |
| | 3.7 | 8.0 | 2.9 | 2.3 | 1.50 | 13.45 |
| | 5.5 | 12.1 | 4.1 | 1.50 | 0.940 | 9.62 |
| | 7.5 | 16.3 | 5.4 | 1.33 | 0.520 | 8.53 |
| | 11 | 23.2 | 7.2 | 1.00 | 0.360 | 4.48 |
| | 15 | 31.0 | 9.0 | 1.00 | 0.250 | 3.38 |
| | 18.5 | 38.0 | 11.0 | 1.00 | 0.168 | 2.457 |
| | 22 | 44.5 | 12.5 | 1.00 | 0.168 | 2.844 |
| | 30 | 60.5 | 16.9 | 1.00 | 0.1266 | 2.133 |
| | 37 | 74.4 | 20.1 | 1.00 | 0.1014 | 1.704 |
| | 45 | 90.3 | 24.4 | 1.00 | 0.0843 | 1.422 |
| | 55 | 106.6 | 28.8 | 1.00 | 0.0693 | 1.167 |
| | 75 | 141.6 | 35.4 | 1.00 | 0.0507 | 0.852 |
| 90 | 167.6 | 41.9 | 1.00 | 0.0399 | 0.715 | |

| Motor Capacity (kW) | Rated Current (A) | No-load Current (A) | Rated Slip Frequency (Hz) | Stator Resistance (Ω) | Leakage Inductance (mH) | |
|---------------------|-------------------|---------------------|---------------------------|--------------------------------|-------------------------|-------|
| 400 V | 110 | 203.5 | 48.8 | 1.00 | 0.0326 | 0.585 |
| | 132 | 242.3 | 58.1 | 1.00 | 0.0272 | 0.488 |
| | 160 | 290.5 | 69.7 | 1.00 | 0.0224 | 0.403 |
| | 185 | 335.0 | 77.0 | 1.00 | 0.0210 | 0.380 |
| | 220 | 405.0 | 93.1 | 1.00 | 0.1630 | 2.930 |
| | 250 | 467.8 | 104.9 | 1.00 | 0.1455 | 2.615 |
| | 315 | 604.0 | 132.8 | 1.00 | 0.1140 | 2.040 |
| | 355 | 687.8 | 146.4 | 1.00 | 0.1020 | 1.820 |
| | 400 | 782.0 | 161.2 | 1.00 | 0.0906 | 1.616 |
| | 500 | 985.3 | 206.2 | 1.00 | 0.0700 | 1.330 |

Auto Tuning Parameter Setting Details

| Code | Description | | | | | | |
|-----------------------|--|----------|----------|---|--|---|--|
| DRV-14 Motor Capacity | Sets the motor capacity to be used. The maximum motor capacity is limited by the inverter capacity and the keypad only displays the inverter capacity. | | | | | | |
| BAS-20 Auto Tuning | Select an auto tuning type and run it. Select one of the options and then press the [ENT] key to run the auto tuning. | | | | | | |
| | <table border="1"> <thead> <tr> <th>Setting</th> <th>Function</th> </tr> </thead> <tbody> <tr> <td>0</td> <td>None Auto tuning function is disabled. Also, if you select one of the auto tuning options and run it, the parameter value will revert back to '0' when the auto tuning is complete.</td> </tr> <tr> <td>1</td> <td>All (rotating type) Measures all motor parameters while the motor is rotating, including stator resistance (Rs), no-load current (Noload Curr), rotor time constant (Tr), etc. Since the motor is rotating while the parameters are being measured, if the load is connected to the motor spindle, the parameters may not be measured accurately. For accurate measurements, remove the load attached to the motor spindle. Note that the rotor time constant (Tr) must be measured in a stopped position.</td> </tr> </tbody> </table> | Setting | Function | 0 | None Auto tuning function is disabled. Also, if you select one of the auto tuning options and run it, the parameter value will revert back to '0' when the auto tuning is complete. | 1 | All (rotating type) Measures all motor parameters while the motor is rotating, including stator resistance (Rs), no-load current (Noload Curr), rotor time constant (Tr), etc. Since the motor is rotating while the parameters are being measured, if the load is connected to the motor spindle, the parameters may not be measured accurately. For accurate measurements, remove the load attached to the motor spindle. Note that the rotor time constant (Tr) must be measured in a stopped position. |
| | Setting | Function | | | | | |
| 0 | None Auto tuning function is disabled. Also, if you select one of the auto tuning options and run it, the parameter value will revert back to '0' when the auto tuning is complete. | | | | | | |
| 1 | All (rotating type) Measures all motor parameters while the motor is rotating, including stator resistance (Rs), no-load current (Noload Curr), rotor time constant (Tr), etc. Since the motor is rotating while the parameters are being measured, if the load is connected to the motor spindle, the parameters may not be measured accurately. For accurate measurements, remove the load attached to the motor spindle. Note that the rotor time constant (Tr) must be measured in a stopped position. | | | | | | |

| Code | Description | | |
|---|---|-------------------|---|
| | 2 | All (static type) | Measures all parameters while the motor is in the stopped position, including stator resistance (Rs), no-load current (Noload Curr), rotor time constant (Tr), etc. Since the motor is not rotating while the parameters are measured, the measurements are not affected when the load is connected to the motor spindle. However, when measuring parameters, do not rotate the motor spindle on the load side. |
| BAS-14 Noload Curr, BAS-21 Rs–BAS-24 Tr | Displays motor parameters measured by auto tuning. For parameters that are not included in the auto tuning measurement list, the default setting will be displayed. | | |

⚠ Caution

- Perform auto tuning ONLY after the motor has completely stopped running.
- Auto tuning operates when the inverter's auto mode is off.
- Before you run auto tuning, check the motor pole number, rated slip, rated current, rated voltage, and efficiency on the motor's rating plate and enter the data. The default parameter setting is used for values that are not entered.
- When measuring all parameters after selecting 2 (All-static type) at BAS-20: compared with rotation type auto tuning where parameters are measured while the motor is rotating, parameter values measured with static auto tuning may be less accurate. Inaccuracy of the measured parameters may degrade the performance of operations. Therefore, run static-type auto tuning by selecting 2 (All) only when the motor cannot be rotated (when gearing and belts cannot be separated easily, or when the motor cannot be separated mechanically from the load).
- If auto tuning operates without wiring the motor, 'Rs Tune Err' or 'Lsig Tune Err' warning messages are displayed. It can be reset if you press 'STOP/RESET' button of the keypad.

5.22 Time Event Scheduling

Time Event function enables the user to operate the inverter using the RTC (Real-Time Clock) feature at certain times that the user would like to set. An RTC battery is installed on the I/O board of the H100 inverter, and it lasts approximately 25,800 hours with the inverter turned off, and 53,300 hours with the inverter turned on.

To use the Time Event, set the current date and time. Three parameters need to be set to configure the Time event feature: Time Period Module, Time Event, and Exception Date.

| Time Period | Description |
|----------------|--|
| Time Period | Used to set the time of operation. |
| Time Event | Used to set the time of operation. |
| Exception Date | Used to specify the exception date. Exception date has the highest priority. |

4 Time period Module types, 8 Time Event Module types, and 8 Exception day types can be used to configure time events. The Time Event function works based on a series of configuration using the modules listed in the table above.

| Group | Code | Name | LCD Display | Parameter Setting | Setting Range | Unit |
|-------|------|-------------------------------|----------------|-------------------|--------------------------------|------|
| AP3 | 01 | Current date | Now Date | 01/01/2000 | 01/01/2000 ~ 12/31/2099 (Date) | Hz |
| | 02 | Current time | Now Time | 0: 00 | 0: 00–23: 59 | Sec |
| | 03 | Current day of the week | Now Weekday | 0000001 | 0000000–1111111 | - |
| | 04 | Summer Time Start date | Summer T Start | 04/01 | 01/01 ~ Summer T Stop | Day |
| | 05 | Summer Time Finish date | Summer T Stop | 11/31 | Summer T Start ~ 12/31(Date) | Day |
| | 10 | Period connection status | Period Status | - | - | - |
| | 11 | Time Period 1 Start time | Period1 StartT | 24: 00 | 00:00 ~ 24:00 | Min |
| | 12 | Time Period 1 End time | Period1 Stop T | 24: 00 | Period1 StartT ~ 24:00(Min) | Min |
| | 13 | Time Period 1 Day of the week | Period1 Day | 0000000 | 0000000~1111111 | - |
| | 14 | Time Period 2 Start time | Period2 StartT | 24: 00 | 00:00 ~ 24:00 | Min |
| | 15 | Time Period 2 | Period2 | 24: 00 | Period2 StartT ~ | Min |

| Group | Code | Name | LCD Display | Parameter Setting | Setting Range | Unit |
|-------|-------|--|----------------|-------------------|-----------------------------|------|
| | | End time | Stop T | | 24:00(Min) | |
| | 16 | Time Period 2 Day of the week | Period2 Day | 00000000 | 0000000~1111111 | - |
| | 17 | Time Period 3 Start time configuration | Period3 StartT | 24: 00 | 00:00 ~ 24:00 | Min |
| | 18 | Time Period 3 End time | Period3 Stop T | 24: 00 | Period3 StartT ~ 24:00(Min) | Min |
| | 19 | Time Period 3 Day of the week | Period3 Day | 00000000 | 0000000~1111111 | - |
| | 20 | Time Period 4 Start time | Period4 StartT | 24: 00 | 00:00 ~ 24:00 | Min |
| | 21 | Time Period 4 End time | Period4 Stop T | 24: 00 | Period4 StartT ~ 24:00(Min) | Min |
| | 22 | Time Period 4 Day of the week | Period4 Day | 00000000 | 0000000~1111111 | - |
| | 30 | Except1 Date Start time | Except1 StartT | 24: 00 | 00:00 ~ 24:00 | Min |
| | 31 | Except1 Date End time | Except1 Stop T | 24: 00 | Except1 StartT ~ 24:00(Min) | Min |
| | 32 | Except1 Date | Except1 Date | 01/01 | 01/01~12/31 | Day |
| | 33-53 | Exception Date 2~Exception Date 8 Parameter (The same condition and setting as Exception Date 1) | | | | |
| | 70 | Time Event functions | Time Event En | 0: No | 0 No 1 Yes | |
| | 71 | Time Event configuration status | T-Event Status | - | - | |
| | 72 | Time Event 1 Connection | T-Event1Period | 000000000000 | 000000000000~111111111111 | |
| | 73 | Time Event 1 | T- | 0: None | 0 None | |

| Group | Code | Name | LCD Display | Parameter Setting | Setting Range | Unit |
|-------|------|-----------|--------------|-------------------|-----------------|------|
| | | functions | Event1Define | | 1 | Fx |
| | | | | 2 | Rx | |
| | | | | 3 | Speed-L | |
| | | | | 4 | Speed-M | |
| | | | | 5 | Speed-H | |
| | | | | 7 | Xcel-L | |
| | | | | 8 | Xcel-M | |
| | | | | 9 | Xcel-H | |
| | | | | 10 | Xcel Stop | |
| | | | | 11 | Run Enable | |
| | | | | 12 | 2nd Source | |
| | | | | 13 | Exchange | |
| | | | | 14 | Analog Hold | |
| | | | | 15 | I-Term Clear | |
| | | | | 16 | PID Openloop | |
| | | | | 17 | PID Gain 2 | |
| | | | | 18 | PID Ref Change | |
| | | | | 19 | 2nd Motor | |
| | | | | 20 | Timer In | |
| | | | | 21 | Dias Aux Ref | |
| | | | | 22 | EPID1 Run | |
| | | | | 23 | EPID1 ITerm Clr | |
| | | | | 24 | Pre Heat | |
| | | | | 25 | EPID2 Run | |
| | | | | 26 | EPID2 iTerm Clr | |
| | | | | 27 | Sleep Wake Chg | |

| Group | Code | Name | LCD Display | Parameter Setting | Setting Range | Unit | |
|-------|-------|---|-------------|-------------------|---------------|----------------|--|
| | | | | | 28 | PID Step Ref L | |
| | | | | | 29 | PID Step Ref M | |
| | | | | | 30 | PID Step Ref H | |
| | 74–87 | Time Event 2–Time Event 8 Parameter (The same setting range and initial value as Time Event 1) | | | | | |

Time Event Function Setting Details

| Code | Description | | | | | | | | |
|--|---|--|----------|---|--|---|--|---|---|
| AP3-01 Now Date AP3-02 Now Time AP3-03 Now Weekday | Sets the current date, time, and day of the week. The Time Event function is based on the setting. When the user sets the summer time start date, the current time is subtracted by one hour. ex) [AP3-04 Summer T Start] is set to April 1, and if it is 1:59 on April 1, it will not be 2:00 a minute later and it will be 1:00 on April 1. If [AP3-05 Summer T Stop] is set to December 25th, then it will be 1:59 on December 25th, and it will be 3:00 on December 25 instead of 2:00 a minute later. Summer time is different for each country. The parameter is based on 2 o'clock. If there is no charge on the RTC battery, it is initialized to 00:00 on January 1, 2000 when the inverter power is off / on. | | | | | | | | |
| AP3-04 Summer T Start AP3-05 Summer T Stop | Set the Summer time start and finish date. | | | | | | | | |
| AP3-06 Date format | Select the desired date format. | | | | | | | | |
| | <table border="1"> <thead> <tr> <th>Configuration</th> <th>Function</th> </tr> </thead> <tbody> <tr> <td>0</td> <td>YYYY/MM/DD Year/Month/Day is displayed.</td> </tr> <tr> <td>1</td> <td>MM/DD/YYYY Month/Day/Year is displayed (USA).</td> </tr> <tr> <td>2</td> <td>DD/MM/YYYY The format of Day/Month/Year is displayed (Europe).</td> </tr> </tbody> </table> | Configuration | Function | 0 | YYYY/MM/DD Year/Month/Day is displayed. | 1 | MM/DD/YYYY Month/Day/Year is displayed (USA). | 2 | DD/MM/YYYY The format of Day/Month/Year is displayed (Europe). |
| | Configuration | Function | | | | | | | |
| | 0 | YYYY/MM/DD Year/Month/Day is displayed. | | | | | | | |
| 1 | MM/DD/YYYY Month/Day/Year is displayed (USA). | | | | | | | | |
| 2 | DD/MM/YYYY The format of Day/Month/Year is displayed (Europe). | | | | | | | | |
| | | | | | | | | | |
| | | | | | | | | | |
| AP3-10 Period Status | Bits 0–3 are used to indicate the time module that is currently in use among the 4 different time modules set at AP3-11–AP3-22. Bits 4–11 are used to indicate the exception day that is set at AP3-30–AP3-53. | | | | | | | | |
| AP3-11–AP3-20 Period 1–4 Start T | The start time for the 4 time periods can be set up to 4. | | | | | | | | |
| AP3-12–AP3-21 Period 1–4 Stop T | The end time for the 4 time periods can be set up to 4. | | | | | | | | |

| Code | Description | | | | | | | | | | | | | | | | | | | | | | | | | | | | | | | | | | | | |
|---------------------------------------|---|------------------|------------------|------------------|-------------------------------|------------------|----------------------------|----------|-----------------|-----------|-----------|-----------|---------------|-----------|-----------|-----------|-----------|---------|-----------|----------|--------|----------|---|---|---|------------------|------------------|------------------|------------------|------------------|------------------|------------------|------------------|----------|----------|----------|----------|
| AP3-13–AP3-22 Period 1~4 Day | <p>The Time period date for the operation can be set up to 4. It can be set on a weekly basis. If the bit is '1 (on)', it indicates the relevant day is selected. If the Bit is '0 (off)', it indicates the relevant day is not selected.</p> <table border="1"> <tr> <th colspan="7">Bit</th> </tr> <tr> <td>6</td> <td>5</td> <td>4</td> <td>3</td> <td>2</td> <td>1</td> <td>0</td> </tr> <tr> <td>Sunday</td> <td>Monday</td> <td>Tuesday</td> <td>Wednesday</td> <td>Thursday</td> <td>Friday</td> <td>Saturday</td> </tr> </table> | Bit | | | | | | | 6 | 5 | 4 | 3 | 2 | 1 | 0 | Sunday | Monday | Tuesday | Wednesday | Thursday | Friday | Saturday | | | | | | | | | | | | | | | |
| Bit | | | | | | | | | | | | | | | | | | | | | | | | | | | | | | | | | | | | | |
| 6 | 5 | 4 | 3 | 2 | 1 | 0 | | | | | | | | | | | | | | | | | | | | | | | | | | | | | | | |
| Sunday | Monday | Tuesday | Wednesday | Thursday | Friday | Saturday | | | | | | | | | | | | | | | | | | | | | | | | | | | | | | | |
| AP3-30–AP3-51 Exception1–8 Start T | The operation start time for the 8 Exception days can be set. | | | | | | | | | | | | | | | | | | | | | | | | | | | | | | | | | | | | |
| AP3-31–AP3-52 Exception1–8 Stop T | The operation end time for the 8 Exception days can be set. | | | | | | | | | | | | | | | | | | | | | | | | | | | | | | | | | | | | |
| AP3-32–AP3-53 Exception1–8 Date | The date for the 8 Exception days can be set. | | | | | | | | | | | | | | | | | | | | | | | | | | | | | | | | | | | | |
| AP3-70 Time Event En | <p>Enables or disables the Time Event</p> <table border="1"> <tr> <th>Setting</th> <th>Function</th> </tr> <tr> <td>0</td> <td>No Time Event is not used.</td> </tr> <tr> <td>1</td> <td>Yes Time Event is used.</td> </tr> </table> | Setting | Function | 0 | No Time Event is not used. | 1 | Yes Time Event is used. | | | | | | | | | | | | | | | | | | | | | | | | | | | | | | |
| Setting | Function | | | | | | | | | | | | | | | | | | | | | | | | | | | | | | | | | | | | |
| 0 | No Time Event is not used. | | | | | | | | | | | | | | | | | | | | | | | | | | | | | | | | | | | | |
| 1 | Yes Time Event is used. | | | | | | | | | | | | | | | | | | | | | | | | | | | | | | | | | | | | |
| AP3-71 T-Event Status | <p>It shows which T-Event from 1–8 is being performed.</p> <table border="1"> <tr> <td>7</td> <td>6</td> <td>5</td> <td>4</td> <td>3</td> <td>2</td> <td>1</td> <td>0</td> </tr> <tr> <td>T-Event 8</td> <td>T-Event 7</td> <td>T-Event 6</td> <td>T-Event 5</td> <td>T-Event 4</td> <td>T-Event 3</td> <td>T-Event 2</td> <td>T-Event 1</td> </tr> </table> | 7 | 6 | 5 | 4 | 3 | 2 | 1 | 0 | T-Event 8 | T-Event 7 | T-Event 6 | T-Event 5 | T-Event 4 | T-Event 3 | T-Event 2 | T-Event 1 | | | | | | | | | | | | | | | | | | | | |
| 7 | 6 | 5 | 4 | 3 | 2 | 1 | 0 | | | | | | | | | | | | | | | | | | | | | | | | | | | | | | |
| T-Event 8 | T-Event 7 | T-Event 6 | T-Event 5 | T-Event 4 | T-Event 3 | T-Event 2 | T-Event 1 | | | | | | | | | | | | | | | | | | | | | | | | | | | | | | |
| AP3-72–86 T-Event1–8 Period | <p>Select the desired module of the Time Module and Exception Day set in AP3-11–AP3-53 for the relevant events. If the bit is 1, it indicates the relevant Time Module or Exception Day is selected. If the Bit is 0, it indicates the Time Module or Exception Day is not selected.</p> <table border="1"> <tr> <th colspan="12">bit</th> </tr> <tr> <td>11</td> <td>10</td> <td>9</td> <td>8</td> <td>7</td> <td>6</td> <td>5</td> <td>4</td> <td>3</td> <td>2</td> <td>1</td> <td>0</td> </tr> <tr> <td>Exception Date 8</td> <td>Exception Date 7</td> <td>Exception Date 6</td> <td>Exception Date 5</td> <td>Exception Date 4</td> <td>Exception Date 3</td> <td>Exception Date 2</td> <td>Exception Date 1</td> <td>Period 4</td> <td>Period 3</td> <td>Period 2</td> <td>Period 1</td> </tr> </table> | bit | | | | | | | | | | | | 11 | 10 | 9 | 8 | 7 | 6 | 5 | 4 | 3 | 2 | 1 | 0 | Exception Date 8 | Exception Date 7 | Exception Date 6 | Exception Date 5 | Exception Date 4 | Exception Date 3 | Exception Date 2 | Exception Date 1 | Period 4 | Period 3 | Period 2 | Period 1 |
| bit | | | | | | | | | | | | | | | | | | | | | | | | | | | | | | | | | | | | | |
| 11 | 10 | 9 | 8 | 7 | 6 | 5 | 4 | 3 | 2 | 1 | 0 | | | | | | | | | | | | | | | | | | | | | | | | | | |
| Exception Date 8 | Exception Date 7 | Exception Date 6 | Exception Date 5 | Exception Date 4 | Exception Date 3 | Exception Date 2 | Exception Date 1 | Period 4 | Period 3 | Period 2 | Period 1 | | | | | | | | | | | | | | | | | | | | | | | | | | |
| AP3-73–87 T-Event1–8 Define | <p>Select the desired Event.</p> <table border="1"> <tr> <th colspan="4">Setting</th> </tr> <tr> <td>0</td> <td colspan="2">None</td> <td>16 PID Openloop</td> </tr> <tr> <td>1</td> <td colspan="2">Fx</td> <td>17 PID Gain 2</td> </tr> </table> | Setting | | | | 0 | None | | 16 PID Openloop | 1 | Fx | | 17 PID Gain 2 | | | | | | | | | | | | | | | | | | | | | | | | |
| Setting | | | | | | | | | | | | | | | | | | | | | | | | | | | | | | | | | | | | | |
| 0 | None | | 16 PID Openloop | | | | | | | | | | | | | | | | | | | | | | | | | | | | | | | | | | |
| 1 | Fx | | 17 PID Gain 2 | | | | | | | | | | | | | | | | | | | | | | | | | | | | | | | | | | |

| Code | | Description | |
|------|--------------|-------------|----------------|
| 2 | Rx | 18 | PID Ref Change |
| 3 | Speed-L | 19 | 2nd Motor |
| 4 | Speed-M | 20 | Timer In |
| 5 | Speed-H | 21 | Dias Aux Ref |
| 6 | Xcel-L | 22 | EPID1 Run |
| 7 | Xcel-M | 23 | EPID1 Openloop |
| 8 | Xcel-H | 24 | Pre Heat |
| 9 | Xcel Stop | 25 | EPID2 Run |
| 10 | Run Enable | 26 | EPID2 Openloop |
| 11 | 2nd Source | 27 | Sleep Wake Chg |
| 12 | Exchange | 28 | PID Step Ref L |
| 13 | Analog Hold | 29 | PID Step Ref M |
| 14 | I-Term Clear | 30 | PID Step Ref H |
| 15 | None | | |

Time Period Parameter Setting

There are 4 Time Period Sets in the Time Event. Each Time Period Set has: period 1–4 Start (Start time), Period 1–4 Stop T (End time), and Period 1–4 Day (Operation day) for which they can be set.

| Time Period | Schedule | | |
|---------------|---|----------------|---------|
| Time Period 1 | Every Sunday, Monday, Wednesday, Thursday, and Friday at 06: 00 (On) and 18: 00 (Off) | | |
| | Time Schedule | | |
| | Code | Function | Setting |
| | AP3-11 | Period1 StartT | 06: 00 |
| | AP3-12 | Period1 StopT | 18: 00 |
| Time Period 2 | Every Sunday and Saturday for 24 hours (On) | | |
| | Time Schedule | | |
| | Code | Function | Setting |
| | AP3-14 | Period2 StartT | 00: 00 |
| | AP3-15 | Period2 StopT | 24: 00 |

| | | | |
|---------------|--|----------------|---------|
| | AP3-16 | Period2 Day | 1000001 |
| Time Period 3 | Every Sunday, Thursday, Friday, and Saturday at 10: 00 (On) and 14: 00 (Off) | | |
| | Time Schedule | | |
| | Code | Function | Setting |
| | AP3-17 | Period3 StartT | 10: 00 |
| | AP3-18 | Period3 StopT | 14: 00 |
| | AP3-19 | Period3 Day | 1000111 |

The tables below show the parameter values for Time Period 1, Time Period 2, and Time Period 3. When the parameters are set for the Time Periods 1-3 as shown in the tables below, this indicates the Time Event function turns on and off on the following days and time.

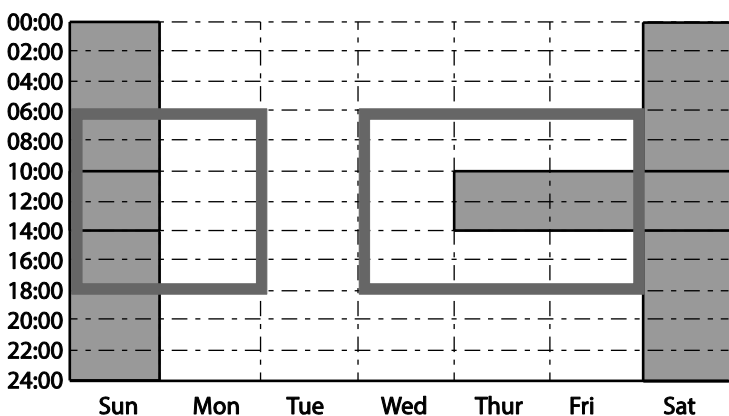

<Time Period setting Time Chart>

Parameters Setting for Exception Date

There are 8 Exception date modules in the Time Event function. They are used to specify the operation on particular days (public holidays, etc.). The settings for the start time and the end time are the same as the settings for the modules and can be set for particular days. The Exception dates can be set redundantly with the Time periods. If the Time Periods and the Exception Dates are set redundantly, the inverter operates on the Exception Dates set.

| Title | Setting Range | Description |
|-------------------|---------------|-------------------------------|
| Except1-8 Start T | 00: 00-24: 00 | Hour: Minutes (by the minute) |

| Title | Setting Range | Description |
|------------------|---------------|--|
| Except1-8 Stop T | 00: 00-24: 00 | Hour: Minutes |
| Except1-8 Date | 1/1-12/31 | Select the particular date (between 1/1 and 12/31) |

| Time Period | Schedule |
|----------------------------------|---|
| Exception Date 1 | Every Sunday, Monday, Wednesday, Thursday, and Friday at 06: 00 (On) and 18: 00 (Off) |
| | Time Schedule |
| | Code Function Setting |
| | AP3-30 Except1 StartT 06: 00 |
| | AP3-31 Except1 StopT 18: 00 |
| Exception Date 2 | Every Sunday and Saturday for 24 hours (On) |
| | Time Schedule |
| | Code Function Setting |
| | AP3-33 Except2 StartT 00: 00 |
| | AP3-34 Except2 StopT 24: 00 |
| Exception Date 3 | Every Sunday, Thursday, Friday, and Saturday at 10: 00 (On) and 14: 00 (Off) |
| | Time Schedule |
| | Code Function Setting |
| | AP3-36 Except3 StartT 10: 00 |
| | AP3-37 Except3 StopT 14: 00 |
| AP3-38 Except3 Day 01/01 | |

| Title | Setting Range | Remarks |
|------------------|---------------|--|
| Except1-8 StartT | 00: 00-24: 00 | Hour: Minutes (by the minute) |
| Except1-8 Stop T | 00: 00-24: 00 | Hour: Minutes |
| Except1-8 Date | 1/1-12/31 | Select the particular date (between 1/1 and 12/31) |

<The Time Chart for the Exception Day>

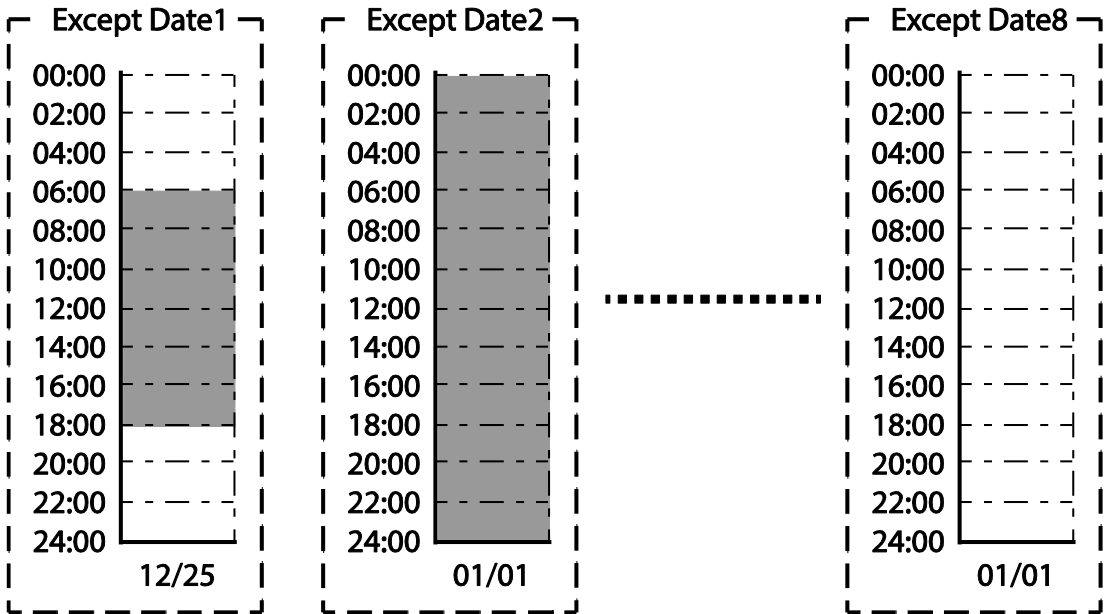

The connection settings for Time Period and Time Event

There are 8 Time event modules in the Time Event function. The parameters for T-Events 1–8 are used to set the connections to each module for the Time Period and the Exception Date. The parameters for T-Event 1–8 are used to specify the operation on particular days. Each Time event module can be set for the connections to 4 Time period modules and 8 Exception days. Time event modules are set as a bit unit in the parameters for Events 1–8. The diagram below shows the connections between the Time event modules and the time period modules. The Time Event 1 is connected to Time Period 4. The Time Event 8 is connected to Time Periods 1–4 and the Exception Dates 2.

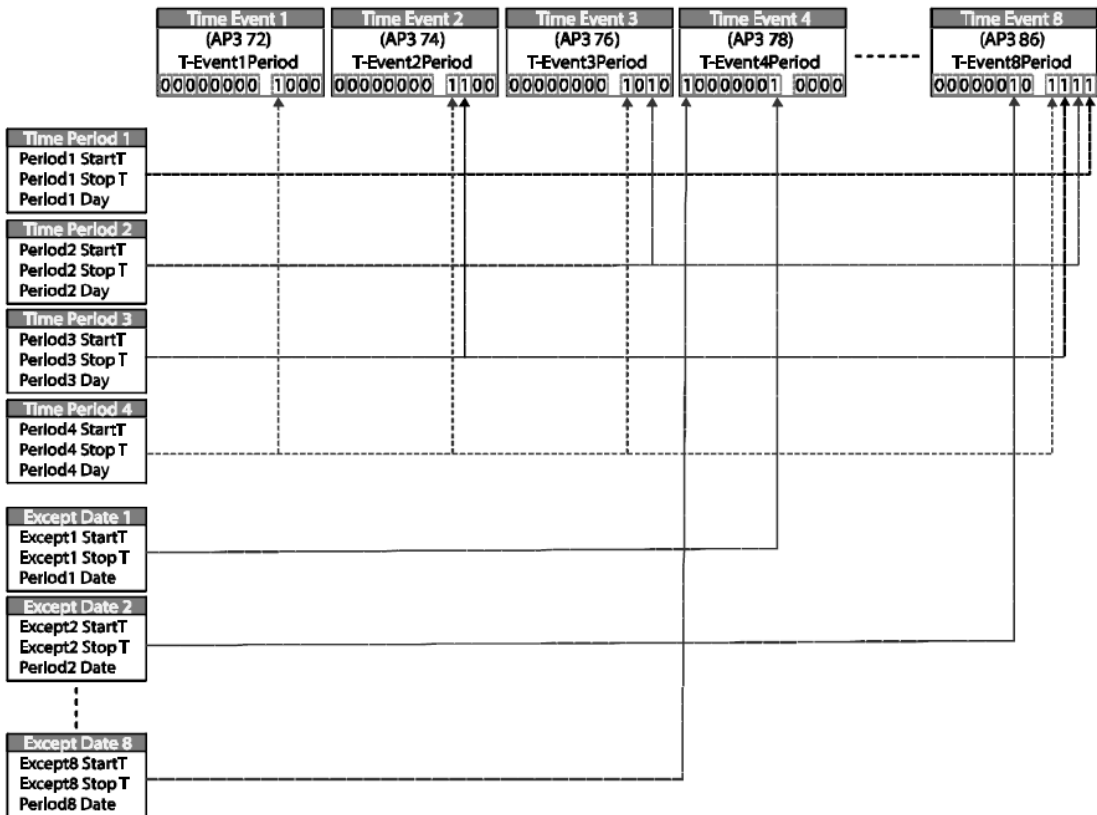

Time Event Module Function Settings

The functions to be performed in the Time Event for T-Events 1–8 can be set. 30 functions can be set (refer to page 218). There are 8 Time event modules in the Time Event. The parameters for T-Events 1–8 are used to set the connections to each module for the Time Period and the Exception Date. The parameters for T-Events 1–8 are used to specify the operation on particular days.

Example of the Time Event operations

If the Time events are set as the parameters below, the inverter operates as illustrated.

| Group | Code | Name | LCD Display | Parameter Setting | Setting Range | Unit | | | | | | | | | | | | | | | | | |
|-------|------------------------|---------------------------------------|----------------|--|--|------|----|----|-----|----|---|---------|---|---------|---|---------|---|--------|---|--------|---|--------|--|
| DRV | 06 | Command Source | Cmd Ref Src | 5: Time Event | 0–9 | - | | | | | | | | | | | | | | | | | |
| | 07 | Frequency command source | Freq Ref Src | 0: KeyPad | 0–11 | - | | | | | | | | | | | | | | | | | |
| AP3 | 11 | Time Period 1 Start time | Period1 StartT | 10: 00 | 00: 00–24: 00 | Min | | | | | | | | | | | | | | | | | |
| | 12 | Time Period 1 End time | Period1 Stop T | 20: 00 | 00: 00–24: 00 | Min | | | | | | | | | | | | | | | | | |
| | 13 | Time Period 1 Day of the week | Period1 Day | 0110000 | 0000000–1111111 | | | | | | | | | | | | | | | | | | |
| | 14 | Time Period 2 Start time | Period2 StartT | 12: 00 | 00: 00–24: 00 | Min | | | | | | | | | | | | | | | | | |
| | 15 | Time Period 2 End time | Period2 Stop T | 17: 00 | 00: 00–24: 00 | Min | | | | | | | | | | | | | | | | | |
| | 16 | Time Period 2 Day of the week | Period2 Day | 00100000 | 0000000–1111111 | - | | | | | | | | | | | | | | | | | |
| | 70 | Time Event configuration | Time Event En | 1: YES | <table border="1"> <tr> <td>0</td> <td>No</td> </tr> <tr> <td>1</td> <td>Yes</td> </tr> </table> | 0 | No | 1 | Yes | - | | | | | | | | | | | | | |
| | 0 | No | | | | | | | | | | | | | | | | | | | | | |
| | 1 | Yes | | | | | | | | | | | | | | | | | | | | | |
| | 72 | Time Event 1 connection configuration | T-Event1Period | 00000000001 | 000000000001–111111111111 | | | | | | | | | | | | | | | | | | |
| 73 | Time Event 1 functions | T-Event1Define | 1: Fx | <table border="1"> <tr> <td>0</td> <td>None</td> </tr> <tr> <td>1</td> <td>Fx</td> </tr> <tr> <td>2</td> <td>Rx</td> </tr> <tr> <td>3</td> <td>Speed-L</td> </tr> <tr> <td>4</td> <td>Speed-M</td> </tr> <tr> <td>5</td> <td>Speed-H</td> </tr> <tr> <td>7</td> <td>Xcel-L</td> </tr> <tr> <td>8</td> <td>Xcel-M</td> </tr> <tr> <td>9</td> <td>Xcel-H</td> </tr> </table> | 0 | None | 1 | Fx | 2 | Rx | 3 | Speed-L | 4 | Speed-M | 5 | Speed-H | 7 | Xcel-L | 8 | Xcel-M | 9 | Xcel-H | |
| 0 | None | | | | | | | | | | | | | | | | | | | | | | |
| 1 | Fx | | | | | | | | | | | | | | | | | | | | | | |
| 2 | Rx | | | | | | | | | | | | | | | | | | | | | | |
| 3 | Speed-L | | | | | | | | | | | | | | | | | | | | | | |
| 4 | Speed-M | | | | | | | | | | | | | | | | | | | | | | |
| 5 | Speed-H | | | | | | | | | | | | | | | | | | | | | | |
| 7 | Xcel-L | | | | | | | | | | | | | | | | | | | | | | |
| 8 | Xcel-M | | | | | | | | | | | | | | | | | | | | | | |
| 9 | Xcel-H | | | | | | | | | | | | | | | | | | | | | | |

| | | | | | | | |
|----|-------------------------|----------------|-------------|---------------------------|----|-----------------|--|
| | | | | | 10 | Xcel Stop | |
| | | | | | 11 | Run Enable | |
| | | | | | 12 | 2nd Source | |
| | | | | | 13 | Exchange | |
| | | | | | 14 | Analog Hold | |
| | | | | | 15 | I-Term Clear | |
| | | | | | 16 | PID Openloop | |
| | | | | | 17 | PID Gain 2 | |
| | | | | | 18 | PID Ref Change | |
| | | | | | 19 | 2nd Motor | |
| | | | | | 20 | Timer In | |
| | | | | | 21 | Dias Aux Ref | |
| | | | | | 22 | EPID1 Run | |
| | | | | | 23 | EPID1 ITerm Clr | |
| | | | | | 24 | Pre Heat | |
| | | | | | 25 | EPID2 Run | |
| | | | | | 26 | EPID2 ITerm Clr | |
| | | | | | 27 | Sleep Wake Chg | |
| | | | | | 28 | PID Step Ref L | |
| | | | | | 29 | PID Step Ref M | |
| | | | | | 30 | PID Step Ref H | |
| 74 | Time Event 2 connection | T-Event1Period | 00000000010 | 000000000001-111111111111 | | | |
| 75 | Time Event 2 functions | T-Event2Define | 3: Speed-L | Refer to AP3-73 | | | |

The parameters in the table above shows the frequency command sources for the keypad and the operation command sources for the Time Event.

The following is an example of an inverter operation utilizing the Time Period modules 1 and 2 with Time Events 1 and 2:

Time Period 1 is used to operate the inverter on Mondays and Tuesdays from 10AM to 8PM. Time Period 2 is used to operate the inverter on Tuesday from 12PM to 5PM.

Time Event 1 triggers forward operations based on the frequency input on the keypad and continues the operation for the time set at Time Period module 1. Time Event 2 operates the inverter at Speed-L for the time set at Time Period module 2.

On Mondays, the inverter operates in the forward direction based on the frequency input on the keypad from 10AM to 8PM (Time Event 1). On Tuesdays, it operates again in the forward direction based on the keypad frequency input from 10AM to 12PM (Time Event 1), and then operates at Speed-L from 12PM to 5PM (Time Event 2). When the operation assigned by Time Event 2 is complete, the inverter resumes its Time Event 1 operation (the inverter operates based on the keypad frequency input from 5PM to 8PM).

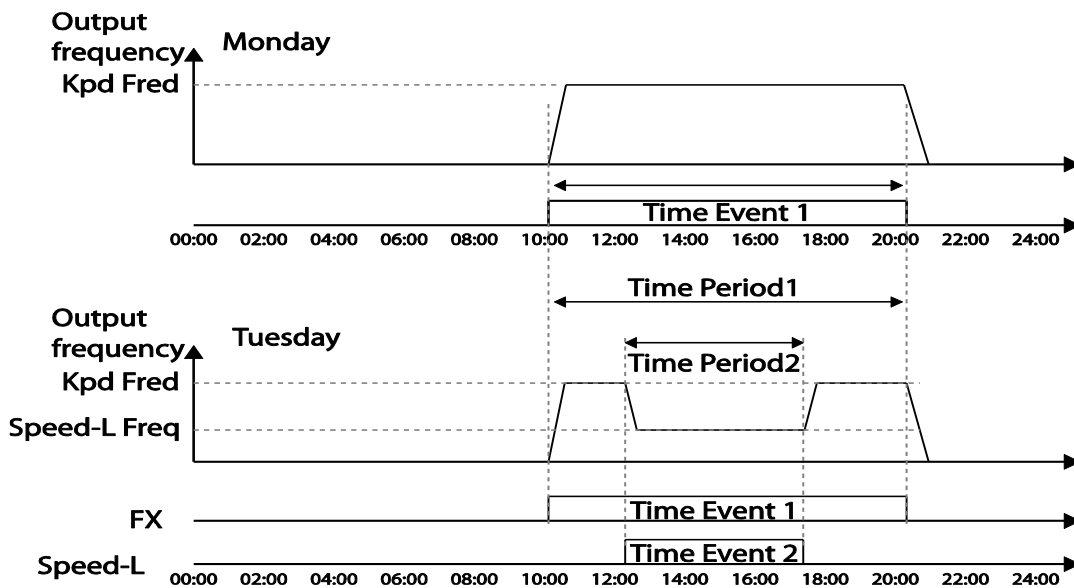

<An example of Time Event>

Note

When repetitive frequency commands related to the frequency input command occur while the Time Event function is performing, Time Event performs its function in the order of the frequency command sources set in Freq Ref Src for DRV-07 (followed by Jog operation and multi-step acc/dec).

⚠ Caution

If a fault trip occurs during a time event operation, the inverter stops the operation and stays in a trip state. When this happens, there are two options to resume the stopped operation:

- Set PRT-08 (RST Restart) to 'YES' to allow the inverter to automatically restart after the trip condition is released.
- Refresh the setting at AP3-70 (Time Event En). Set AP3-70 to 'Yes' from 'No'. If one of the input terminals (IN-65–71 Px Define) is assigned to it, turn the switch off then turn it back on to resume the time event operation.

5.23 Kinetic Energy Buffering

When the input power supply is disconnected, the inverter's DC link voltage decreases, and a low voltage trip occurs blocking the output. A kinetic energy buffering operation uses regenerative energy generated by the motor during the blackout to maintain the DC link voltage. This extends the time for a low voltage trip to occur, after an instantaneous power interruption.

| Group | Code | Name | LCD Display | Parameter Setting | | Setting range | Unit |
|-------|------|--|---------------|-------------------|-----------|---------------|------|
| CON | 77 | Kinetic energy buffering selection | KEB Select | 1 | Yes | 0-1 | - |
| | 78 | Kinetic energy buffering start level | KEB Start Lev | 130 | | 110-140 | % |
| | 79 | Kinetic energy buffering stop level | KEB Stop Lev | 135 | | 115-145 | % |
| | 80 | Kinetic energy buffering slip gain | KEB Slip Gain | 300 | | 0-20000 | - |
| | 81 | Kinetic energy buffering P-Gain | KEB P Gain | 1000 | | 0-20000 | - |
| | 82 | Kinetic energy buffering I gain | KEB I Gain | 500 | | 1-20000 | - |
| | 83 | Kinetic energy buffering acceleration time | KEB Acc Time | 10.0 | 0.75~90kW | 0.0-600.0 | Sec |
| | | | 30.0 | 110~500kW | | | |

Kinetic Energy Buffering Operation Setting Details

| Code | Description | | | | | | |
|--|---|----------|----------|------|--|-------|---|
| CON-77 KEB Select | Select the kinetic energy buffering operation when the input power is disconnected. | | | | | | |
| | <table border="1"> <thead> <tr> <th>Setting</th> <th>Function</th> </tr> </thead> <tbody> <tr> <td>0 No</td> <td>General deceleration is carried out until a low voltage trip occurs.</td> </tr> <tr> <td>1 Yes</td> <td>The inverter power frequency is controlled and the regeneration energy from the motor is charged by the inverter.</td> </tr> </tbody> </table> | Setting | Function | 0 No | General deceleration is carried out until a low voltage trip occurs. | 1 Yes | The inverter power frequency is controlled and the regeneration energy from the motor is charged by the inverter. |
| | Setting | Function | | | | | |
| 0 No | General deceleration is carried out until a low voltage trip occurs. | | | | | | |
| 1 Yes | The inverter power frequency is controlled and the regeneration energy from the motor is charged by the inverter. | | | | | | |
| CON-78 KEB Start Lev, CON-79 KEB Stop Lev | Sets the start and stop points of the kinetic energy buffering operation. The set values must be based on the low voltage trip level at 100%, and the stop level (CON-79) must be set higher than the start level (CON-78). | | | | | | |
| CON-80 KEB Slip Gain | Used to prevent malfunctions caused by low voltage from initial kinetic energy buffering occurring due to power interruptions. | | | | | | |
| CON-81 KEB P Gain | Used to maintain the voltage during the kinetic energy buffering operation. It operates the inverter by modifying the set value to prevent malfunctions caused by low voltage after power interruptions. | | | | | | |
| CON-82 | Used to maintain the voltage during the kinetic energy buffering operation. | | | | | | |

| Code | Description |
|------------------------|---|
| KEB I Gain | Sets the gain value to maintain the operation until the frequency stops during the kinetic energy buffering operation. |
| CON-83 KEB Acc Time | Sets the acceleration time for the frequency reference when the inverter's operation becomes normal after the kinetic energy buffering operation. |

Note

- The KEB functions may perform differently depending on the size of the loads. The KEB Gains can be set for a better performance.
- If a low voltage trip occurs after a power interruption, it indicates the load inertia and level are high. In such cases, the KEB functions can be performed better by increasing the KEB I Gain and the KEB Slip Gain.
- If motor vibration or torque variation occurs during the KEB function operation after power interruptions, the KEB functions can be performed better by increasing the KEB P Gain or decreasing the KEB I Gain.

⚠ Caution

Depending on the duration of instantaneous power interruptions and the amount of load inertia, a low voltage trip may occur even during a kinetic energy buffering operation. Motors may vibrate during kinetic energy buffering operation for some loads, except for variable torque loads (for example, fan or pump loads).

5.24 Anti-hunting Regulation (Resonance Prevention)

This function is used to prevent the hunting of a V/F controlled fan or motor caused by current distortion or oscillation, due to mechanical resonance or other reasons.

| Group | Code | Name | LCD Display | Parameter Setting | | Setting Range | | Unit |
|-------|------|--|-------------|-------------------|-----|---------------|-----|------|
| CON | 13 | Enable or disable anti-hunting regulation (resonance prevention) | AHR Sel | 1 | Yes | 0 | No | - |
| | | | | | | 1 | Yes | |

| Group | Code | Name | LCD Display | Parameter Setting | Setting Range | Unit |
|-------|------|--|---------------|-------------------|---------------------|------|
| | 14 | Anti-hunting regulation P-Gain | AHR P-Gain | 1000 | 0–32767 | - |
| | 15 | Anti-hunting regulation start frequency | AHR Low Freq | 0 | 0–AHR High Freq | Hz |
| | 16 | Anti-hunting regulation end frequency | AHR High Freq | 400.00 | AHR Low Freq–400.00 | Hz |
| | 17 | Anti-hunting regulation compensation voltage limit | AHR Limit | 2 | 0–20 | % |

Anti-hunting Regulation Setting Details

| Code | Description | | | | | | |
|---|--|----------|----------|---|----|---|-----|
| CON-13 AHR Sel | Selects the Anti-hunting regulator operation. | | | | | | |
| | <table border="1"> <thead> <tr> <th>Setting</th> <th>Function</th> </tr> </thead> <tbody> <tr> <td>0</td> <td>No</td> </tr> <tr> <td>1</td> <td>Yes</td> </tr> </tbody> </table> | Setting | Function | 0 | No | 1 | Yes |
| | Setting | Function | | | | | |
| | 0 | No | | | | | |
| 1 | Yes | | | | | | |
| 0 | No | | | | | | |
| 1 | Yes | | | | | | |
| CON-14 AHR P-Gain | Increasing AHR proportional gain improves responsiveness of the anti-hunting regulation. However, current oscillation may result if AHR proportional gain is set too high. | | | | | | |
| CON-15 AHR Low Freq CON-16 AHR High Freq | Sets the lower limit frequency (CON-15) and the maxim limit frequency (CON-16) for anti-hunting regulation. | | | | | | |

5.25 Fire Mode Operation

This function is used to allow the inverter to ignore minor faults during emergency situations, such as fire, and provides continuous operation to protect other systems, such as ventilating fans. In Fire mode, the inverter continues to operate based on the Fire mode run direction and frequency set at PRT-46 and PRT-47.

| Group | Code | Name | LCD Display | Parameter Setting | Setting Range | Unit |
|-------|------|--------------------|--------------|-------------------|---------------|------|
| PRT | 44 | Fire mode password | Fire Mode PW | 3473 | - | - |

| Group | Code | Name | LCD Display | Parameter Setting | Setting Range | Unit | |
|-------|-------|------------------------------|----------------|-------------------|---------------|-----------|---|
| | 45 | Fire mode setting | Fire Mode Sel | 0: None | 0 | None | - |
| | | | | | 1 | Fire Mode | |
| | | | | | 2 | Test Mode | |
| | 46 | Fire mode run direction | Fire Mode Dir | 0: Forward | 0 | Forward | - |
| 1 | | | | | Reverse | | |
| | 47 | Fire mode run frequency | Fire Mode Freq | 60.00 | 0–max Freq | Hz | |
| | 48 | Fire mode operation count | Fire Mode Cnt | 0 | - | - | |
| IN | 65–75 | Digital input configuration | Px Define | 40: Fire Mode | 0-55 | - | |
| OUT | 31–35 | Digital output configuration | Relay1-5 | 27: Fire Mode | 0-41 | - | |
| | 36 | TR output configuration | Q1 define | 27: Fire Mode | 0-41 | - | |

When the multi-function terminal configured for Fire mode is turned on, the inverter ignores all other commands and operates in the direction set at PRT-46 (Fire mode run direction) at the speed set at PRT-47 (Fire mode run frequency). In Fire mode, the inverter ignores any faults, other than 'ASHT,' 'Over Current 1,' 'Over Voltage,' 'Ground F,' and continues to operate. If any of the faults that can stop inverter operation occur, the inverter automatically performs a reset restart to continue the operation.

Fire Mode Function Setting Details

| Code | Description |
|---------------------|---|
| PRT-44 Fire Mode PW | Fire mode password is 3473. A password must be created to enable Fire mode. PRT-45 (Fire Mode Sel) can be modified only after the password is entered. |

| Code | Description | | |
|-----------------------|---|-----------|---|
| PRT-45 Fire Mode Sel | Sets the Fire Mode. | | |
| | Setting | | Function |
| | 0 | None | Fire mode is not used. |
| | 1 | Fire Mode | Normal Fire mode |
| PRT-46 Fire Mode Dir | 2 | Test Mode | Fire mode test mode In Fire test mode, faults are normally processed. Using Fire test mode does not increase the count value at PRT-48 (Fire Mode Cnt). |
| | Sets the run direction for Fire mode operation. | | |
| PRT-47 Fire Mode Freq | Sets the operation frequency for Fire mode. | | |
| PRT-48 Fire Mode Cnt | Counts the number of the Fire mode operations. The number increases only when PRT-45 (Fire Mode Sel) is set to 'Fire Mode'. The count increases up to 99, then it does not increase any more. | | |

⚠ Caution

- If damper or lubrication operations are set for the inverter, Fire mode operation is performed after the delay times set in the relevant operations.
- Note that Fire mode operation voids the product warranty.
- In Fire mode test mode, the inverter does not ignore the fault trips or perform a reset restart. All the fault trips will be processed normally. Fire mode test mode does not increase the Fire mode count (PRT-48).
- When the Fire mode operation is complete, the inverter stops operating and is turned off.

5.26 Energy Saving Operation

5.26.1 Manual Energy Saving Operation

If the inverter output current is lower than the current set at BAS-14 (Noload Curr), the output voltage must be reduced as low as the level set at ADV-51 (Energy Save). The voltage before the energy saving operation starts will become the base value of the percentage. Manual energy saving operation will not be carried out during acceleration and deceleration.

| Group | Code | Name | LCD Display | Parameter Setting | | Setting Range | | Unit |
|-------|------|-------------------------|-------------|-------------------|--------|---------------|--------|------|
| ADV | 50 | Energy saving operation | E-Save Mode | 1 | Manual | 0 | None | - |
| | | | | | | 1 | Manual | |
| | | | | | | 2 | Auto | |
| | 51 | Energy saving amount | Energy Save | 30 | | 0-30 | % | |

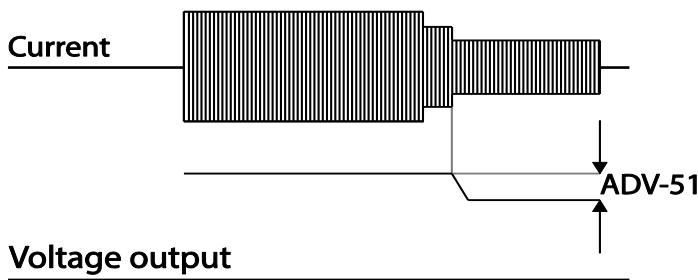

5.26.2 Automatic Energy Saving Operation

The inverter finds the optimal energy saving point for the time set at ADV-52 based on the rated motor current and the voltage output. The Energy saving operation is effective for the normal duty operations. It does operate when the load level is more than 80% of the rated motor current.

| Group | Code | Name | LCD Display | Parameter Setting | | Setting Range | Unit |
|-------|------|---------------------------------|--------------|-------------------|------|---------------|------|
| ADV | 50 | Energy saving operation | E-Save Mode | 2 | Auto | 0-2 | - |
| | 52 | Energy saving point search time | E-Save Det T | 20.0 | | 0.0-100.0 | Sec |



⚠ Caution

If the operation frequency is changed, or acceleration or deceleration is carried out during an energy saving operation, the actual Acc/Dec time may take longer than the set time due to the time required to return to general operations from the energy saving operation.

5.27 Speed Search Operation

Speed search operation is used to prevent fault trips that can occur when the inverter voltage output is disconnected and the motor is idling. Since this feature estimates the motor rotation speed based on the inverter output current, it does not give the exact speed.

| Group | Code | Name | LCD Display | Parameter Setting | | Setting Range | Unit |
|-------|---------------------------------------|----------------------------------|----------------|-------------------|----------------|---------------|------|
| CON | 70 | Speed search mode selection | SS Mode | 0 | Flying Start-1 | - | - |
| | 71 | Speed search operation selection | Speed Search | 0000 | | - | bit |
| | 72 | Speed search reference current | SS Sup-Current | 90 | 0.75~90kW | 50~120 | % |
| | | | | 80 | 110~500kW | | |
| | 73 | Speed search proportional gain | SS P-Gain | 100 | | 0~9999 | - |
| | 74 | Speed search integral gain | SS I-Gain | 200 | | 0~9999 | - |
| 75 | Output block time before speed search | SS Block Time | 1.0 | | 0~60 | sec | |
| OUT | 31 | Multi-function relay 1 item | Relay 1 | 19 | Speed Search | - | - |
| | 33 | Multi-function output 1 item | Q1 Define | | | | |

| Code | Description | | | |
|---------------------|---|---|---|---------------------------------------|
| CON-70 SS Mode | Select a speed search type. | | | |
| | Setting | Function | | |
| | 0 | Flying Start-1 The speed search is carried out as it controls the inverter output current during idling below the CON-72 (SS Sup-Current) parameter setting. If the direction of the idling motor and the direction of operation command at restart are the same, a stable speed search function can be performed at about 10 Hz or lower. However, if the direction of the idling motor and the direction of operation command at restart are different, the speed search does not produce a satisfactory result because the direction of idling cannot be established. | | |
| 1 | Flying Start-2 The speed search is carried out as it PI controls the ripple current which is generated by the counter electromotive force during no-load rotation. Because this mode establishes the direction of the idling motor (forward/reverse), the speed search function is stable regardless of the direction of the idling motor and direction of operation command. However because the ripple current is used which is generated by the counter electromotive force at idle (the counter electromotive force is proportional to the idle speed), the idle frequency is not determined accurately and re-acceleration may start from zero speed when the speed search is performed for the idling motor at low speed (about 10 - 15 Hz, though it depends on motor characteristics). | | | |
| CON-71 Speed Search | Speed search can be selected from the following 4 options. If the top display segment is on, it is enabled (On). If the bottom segment is on, it is disabled (Off). | | | |
| | Item | Bit Setting On Status | Bit setting Off Status | |
| | Keypad |  |  | |
| | Type and Functions of Speed Search Setting | | | |
| Setting | | | | Function |
| bit4 | bit3 | bit2 | bit1 | |
| | | | ✓ | Speed search for general acceleration |
| | | ✓ | | Initialization after a fault trip |

| | | | | |
|---|---|--|--|--|
| | ✓ | | | Restart after instantaneous power interruption |
| ✓ | | | | Starting with power-on |

Speed search for general acceleration: If bit 1 is set to '1' and the inverter operation command runs, acceleration starts with the speed search operation. When the motor is rotating under load, a fault trip may occur if the operation command is run for the inverter to provide voltage output. The speed search function prevents such fault trips from occurring.

Initialization after a fault trip other than an LV trip: If bit 2 is set to '1' and PRT-08 (RST Restart) is set to '1 (Yes)', the speed search operation automatically accelerates the motor to the operation frequency used before the fault trip when the [Reset] key is pressed (or the terminal block is initialized) after a fault trip.

Automatic restart after a power interruption: If bit 3 is set to '1,' and if a low voltage trip occurs due to a power interruption but the power is restored before the internal power shuts down, the speed search operation accelerates the motor back to its frequency reference before the low voltage trip.

If an instantaneous power interruption occurs and the input power is disconnected, the inverter generates a low voltage trip and blocks the output. When the input power returns, the operation frequency before the low voltage trip and the voltage is increased by the inverter's inner PI control.

If the current increases above the value set at CON-72, the voltage stops increasing and the frequency decreases (t1 zone). If the current decreases below the value set at CON-27, the voltage increases again and the frequency stops decelerating (t2 zone). When the normal frequency and voltage are resumed, the speed search operation accelerates the motor back to its frequency reference before the fault trip.

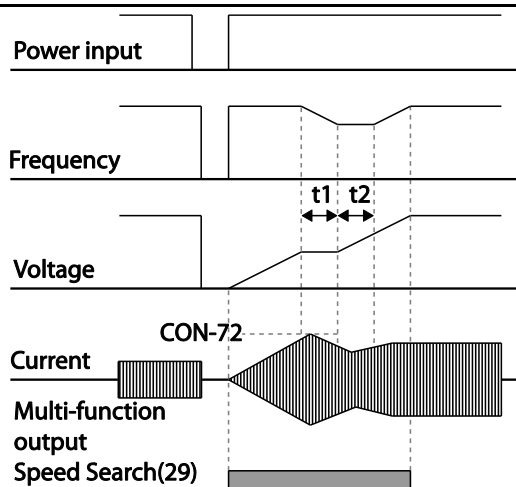

Starting with power-on: Set bit 4 to '1' and ADV-10 (Power-on Run) to '1 (Yes)'. If inverter input power is supplied while the inverter operation command is on, the speed search operation will accelerate the motor up to the frequency reference.

| | |
|------------------------------------|--|
| CON-72 SS Sup-Current | The amount of current flow is controlled during speed search operation based on the motor's rated current. If CON-70 (SS mode) is set to '1 (Flying Start-2)', this code is not visible. |
| CON-73 SS P-Gain, CON-74 SS I-Gain | The P/I gain of the speed search controller can be adjusted. If CON-70 (SS Mode) is set to '1 (Flying Start-2)', different factory defaults, based on motor capacity, are used and defined in DRV-14 (Motor Capacity). |
| CON-75 SS Block Time | The block time parameter prevents overvoltage trips due to counter electromotive force. |

Note

If operated within the rated output, the H100 series inverter is designed to withstand instantaneous power interruptions within 8 ms and maintain normal operation. The DC voltage inside the inverter may vary depending on the output load. If the power interruption time is longer than 8 ms, a low voltage trip may occur.

⚠ Caution

Select the Speed search function (normal acceleration) for a proper re-operation during a free-run. If the speed search function (normal acceleration) is not selected during the acceleration, an over current trip or an overload trip may occur.

Speed Search Operation Setting Details

5.28 Auto Restart Settings

When inverter operation stops due to a fault and a fault trip is activated, the inverter automatically restarts based on the parameter settings.

| Group | Code | Name | LCD Display | Parameter Setting | Setting Range | Unit |
|-------|------|---------------------------------------|----------------|-------------------|---------------|------|
| PRT | 08 | Select start at trip reset | RST Restart | 11 | - | - |
| | 09 | Auto restart count | Retry Number | 6 | 0–10 | - |
| | 10 | Auto restart delay time | Retry Delay | 1.0 | 0.1–60.0 | sec |
| CON | 71 | Select speed search operation | Speed Search | - | 0000–1111 | bit |
| | 72 | Speed search startup current | SS Sup-Current | 90 | 70–120 | % |
| | 73 | Speed search proportional gain | SS P-Gain | 100 | 0–9999 | |
| | 74 | Speed search integral gain | SS I-Gain | 200 | 0–9999 | |
| | 75 | Output block time before speed search | SS Block Time | 1.0 | 0.0–60.0 | sec |

Auto Restart Setting Details

| Code | Description | | | |
|-----------------------|--|---------|--------|---------|
| PRT-08 RST Restart | The Reset restart function can be performed by one of the two different types. If the top segment is turned on, it indicates the function is on. If the bottom segment is turned on, it indicates the function is off. | | | |
| | <table border="1"> <tr> <td>Type</td> <td>Bit On</td> <td>Bit Off</td> </tr> </table> | Type | Bit On | Bit Off |
| Type | Bit On | Bit Off | | |

| Code | Description | | | | | | | | | | | | |
|--|--|-------------------------------|--|----------|------|-------|--|--|---|-------------------------------|---|--|--------------------|
| | <div style="display: flex; align-items: center;"> <div style="margin-right: 10px;">LCD Display</div>  </div> <p>Reset Restart function</p> <table border="1" style="width: 100%;"> <thead> <tr> <th colspan="2">Setting</th> <th>Function</th> </tr> <tr> <th>Bit1</th> <th>Bit 0</th> <th></th> </tr> </thead> <tbody> <tr> <td></td> <td style="text-align: center;">✓</td> <td>For fault trips other than LV</td> </tr> <tr> <td style="text-align: center;">✓</td> <td></td> <td>For LV fault trips</td> </tr> </tbody> </table> <p>For fault trips other than LV: If the Bit 0 is turned on, the inverter restarts after a trip occurs and triggers a reset.</p> <p>For LV fault trips: If the Bit 1 is turned on, the inverter restarts after a trip occurs and triggers a reset.</p> | Setting | | Function | Bit1 | Bit 0 | | | ✓ | For fault trips other than LV | ✓ | | For LV fault trips |
| Setting | | Function | | | | | | | | | | | |
| Bit1 | Bit 0 | | | | | | | | | | | | |
| | ✓ | For fault trips other than LV | | | | | | | | | | | |
| ✓ | | For LV fault trips | | | | | | | | | | | |
| PRT-09 Retry Number, PRT-10 Retry Delay | <p>The number of available auto restarts can be set at PRT-09. If a fault trip occurs during an operation, the inverter restarts after the time set at PRT-10 (Retry Delay). At each restart, the inverter counts the number of tries and subtracts it from the number set at PRT-09 until the retry number count reaches 0. After an auto restart, if a fault trip does not occur within 60 sec, it will increase the restart count number. The maximum count number is limited by the number set at PRT-09.</p> <p>If the inverter stops due to over current or hardware diagnosis, an auto restart is not activated. At auto restart, the acceleration options are identical to those of speed search operation. Codes CON-72–75 can be set based on the load. Information about the speed search function can be found at 5.27 Speed Search Operation on page 234.</p> | | | | | | | | | | | | |

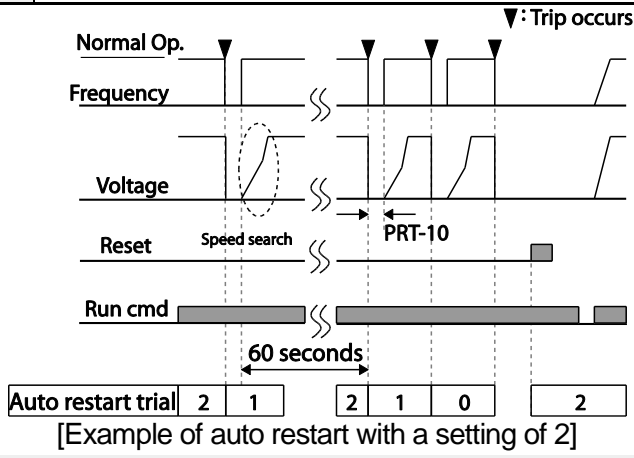

⚠ Caution

- If the auto restart number is set, be careful when the inverter resets from a fault trip. The motor may automatically start to rotate.
- In HAND mode, auto restart resets the trip condition but it does not restart the inverter operation.

- In AUTO mode,
 - if the auto restart is configured, the inverter restarts after a trip condition is released (command via digital input is used to restart the operation).
 - if the auto restart is not configured and the trip condition is released using the OFF key, or the switches at the terminal input, the inverter stays in the OFF state. Because the command information is reset along with the trip condition, a new command is required to operate the inverter.

5.29 Operational Noise Settings (Carrier Frequency Settings)

| Group | Code | Name | LCD Display | Parameter Setting | | Setting Range | Unit |
|-------|------|-------------------|--------------|-------------------|------------|---------------|------|
| CON | 04 | Carrier Frequency | Carrier Freq | 3.0 | 0.75~90kW | 1.0~15.0 | kHz |
| | | | | 2.0 | 110~355kW | 1.0~5.0 | |
| | | | | 1.5 | 400/500kW | 1.0~4.0 | |
| | 05 | Switching Mode | PWM* Mode | 0 | Normal PWM | 0~1 | - |

* PWM: Pulse width modulation

Operational Noise Setting Details

| Code | Description | | | | | | |
|------------------------|---|--------|-------------------|--|--|---------|--------|
| CON-04 Carrier Freq | Adjusts motor operational noise by changing carrier frequency settings. Power transistors (IGBT) in the inverter generate and supply high frequency switching voltage to the motor. The switching speed in this process refers to the carrier frequency. If the carrier frequency is set high, it reduces operational noise from the motor. If the carrier frequency is set low, it increases operational noise from the motor. | | | | | | |
| CON-05 PWM Mode | The heat loss and leakage current from the inverter can be reduced by changing the load rate option at CON-05 (PWM Mode). Selecting '1 (LowLeakage PWM)' reduces heat loss and leakage current, compared to when '0 (Normal PWM)' is selected. However, it increases the motor noise. Low leakage PWM uses a 2 phase PWM modulation mode, which helps minimize degradation and reduces switching loss by approximately 30%. | | | | | | |
| | <table border="1"> <thead> <tr> <th>Item</th> <th colspan="2">Carrier Frequency</th> </tr> </thead> <tbody> <tr> <td></td> <td>1.0 kHz</td> <td>15 kHz</td> </tr> </tbody> </table> | Item | Carrier Frequency | | | 1.0 kHz | 15 kHz |
| Item | Carrier Frequency | | | | | | |
| | 1.0 kHz | 15 kHz | | | | | |

| Code | Description | | |
|------|-----------------|----------------|------------|
| | | LowLeakage PWM | Normal PWM |
| | Motor noise | ↑ | ↓ |
| | Heat generation | ↓ | ↑ |
| | Leakage current | ↓ | ↑ |
| | Leakage current | ↓ | ↑ |

Note

- **Carrier Frequency at Factory Default Settings:**
 - 0.75~90kW : 3 kHz, 110~355kW : 2kHz, 400/500kW : 1.5kHz
- **H100 Series Inverter Derating Standard (Derating):** The over load rate represents an acceptable load amount that exceeds rated load, and is expressed as a ratio based on the rated load and the duration. The overload capacity on the H100 series inverter is 120%/1 min for normal loads. The current rating differs from the load rating, as it also has an ambient temperature limit. For derating specifications refer to 11.8 Inverter Continuous Rated Current Derating on page 578.
- Current rating for ambient temperature at normal load operation.

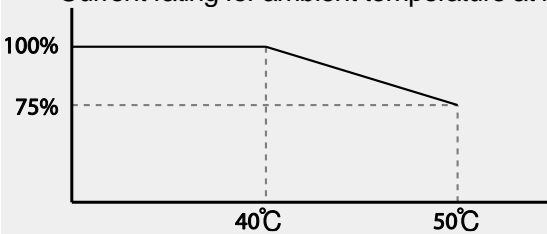

5.30 2nd Motor Operation

The 2nd motor operation is used when a single inverter switch operates two motors. Using the 2nd motor operation, a parameter for the 2nd motor is set. The 2nd motor is operated when a multi-function terminal input, defined as a 2nd motor function, is turned on.

| Group | Code | Name | LCD Display | Parameter Setting | | Setting Range | Unit |
|-------|-------|---------------------------|-----------------------|-------------------|-----------|---------------|------|
| IN | 65–71 | Px terminal configuration | Px Define (Px: P1–P7) | 28 | 2nd Motor | 0-55 | - |

2nd Motor Operation Setting Details

| Code | Description |
|--------------------|---|
| IN-65–71 Px Define | Set one of the multi-function input terminals (P1–P5) to 26 (2nd Motor) to display the M2 (2nd motor group) group. An input signal to a multi-function terminal set to 2nd motor will operate the motor according to the code settings listed below. However, if the inverter is in operation, input signals to the multi-function terminals will not read as a 2nd motor parameter. PRT-50 (Stall Prevent) must be set first, before M2-28 (M2-Stall Lev) settings can be used. Also, PRT-40 (ETH Trip Sel) must be set first, before M2-29 (M2-ETH 1 min) and M2-30 (M2-ETH Cont) settings. |

Parameter Setting at Multi-function Terminal Input on a 2nd Motor

| Code | Description | Code | Description |
|----------------------|----------------------|---------------------|---|
| M2-04 Acc Time | Acceleration time | M2-15 M2-Efficiency | Motor efficiency |
| M2-05 M2-Dec Time | Deceleration time | M2-17 M2-Rs | Stator resistance |
| M2-06 M2-Capacity | Motor capacity | M2-18 M2-Lsigma | Leakage inductance |
| M2-07 M2-Base Freq | Motor base frequency | M2-25 M2-V/F Patt | V/F pattern |
| M2-08 M2-Ctrl Mode | Control mode | M2-26 M2-Fwd Boost | Forward torque boost |
| M2-10 M2-Pole Num | Pole number | M2-27 M2-Rev Boost | Reverse torque boost |
| M2-11 M2-Rate Slip | Rated slip | M2-28 M2-Stall Lev | Stall prevention level |
| M2-12 M2-Rated Curr | Rated current | M2-29 M2-ETH 1 min | Motor heat protection 1 min rating |
| M2-13 M2-Noload Curr | No-load current | M2-30 M2-ETH Cont | Motor heat protection continuous rating |
| M2-14 M2-Rated Volt | Motor rated voltage | | |

Example - 2nd Motor Operation

Use the 2nd motor operation when switching operation between a 7.5 kW motor and a secondary 3.7 kW motor connected to terminal P3. Refer to the following settings.

| Group | Code | Name | LCD Display | Parameter Setting | | Setting Range | Unit |
|-------|------|---------------------------|--------------|-------------------|-----------|---------------|------|
| IN | 67 | Terminal P3 configuration | P3 Define | 26 | 2nd Motor | - | - |
| M2 | 06 | Motor capacity | M2-Capacity | - | 3.7 kW | - | - |
| | 08 | Control mode | M2-Ctrl Mode | 0 | V/F | - | - |

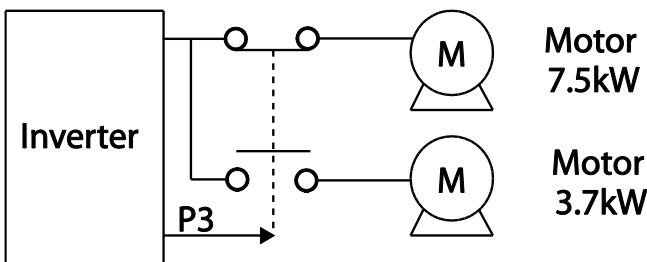

5.31 Supply Power Transition

A supply power transition is used to switch the power source for the motor connected to the inverter from the inverter output power to the main supply power source (commercial power source), or vice versa.

| Group | Code | Name | LCD Display | Parameter Setting | | Setting Range | Unit |
|-------|-------|-------------------------------|-----------------------|-------------------|---------------|---------------|------|
| IN | 65–71 | Px terminal configuration | Px Define (Px: P1–P7) | 18 | Exchange | 0-55 | - |
| OUT | 31 | Multi-function relay 1 items | Relay1 | 17 | Inverter Line | 0-41 | - |
| | 33 | Multi-function output 1 items | Q1 Define | 18 | Comm Line | 0-41 | - |

| Code | Description |
|-----------------------|--|
| IN-65–71 Px Define | When the motor power source changes from inverter output to main supply power, select a terminal to use and set the code value to '18 (Exchange)'. Power will be switched when the selected terminal is on. To |

reverse the transition, switch off the terminal.

OUT-31 Relay 1–
OUT-36 Q1 Define

Set multi-function relay or multi-function output to '17 (Inverter Line)' or '18 (Comm Line)'. The relay operation sequence is as follows.

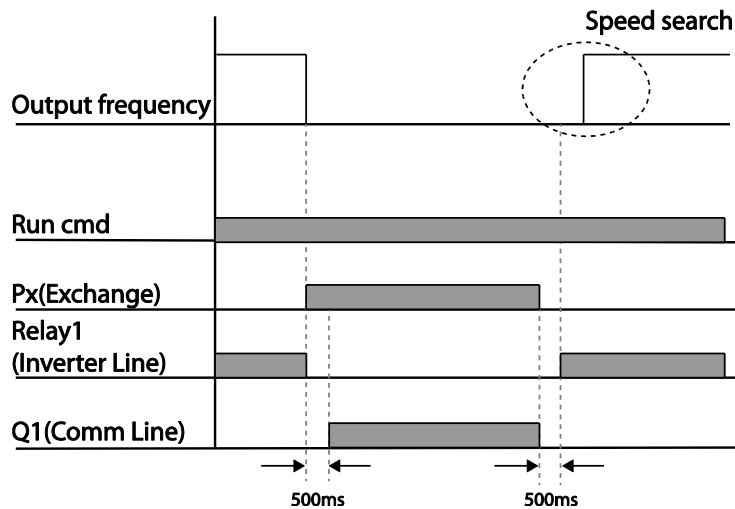

Supply Power Transition Setting Details

5.32 Cooling Fan Control

This function turns the inverter’s heat-sink cooling fan on and off. It is used in situations where the load stops and starts frequently or a noise-free environment is required. The correct use of cooling fan controls can extend the cooling fan’s life.

| Group | Code | Name | LCD Display | Parameter Setting | Setting Range | Unit |
|-------|------|---------------------|-------------|-------------------|---------------|------|
| ADV | 64 | Cooling fan control | Fan Control | 0 During Run | 0–2 | - |

Cooling Fan Control Detail Settings

| Code | Description | |
|--------------------|----------------|--|
| ADV-64 Fan Control | Settings | Description |
| | 0 During Run | The cooling fan runs when the power is supplied to the inverter and the operation command is on. The cooling fan stops when the power is supplied to the inverter and the operation command is off. When the |

| Code | Description | |
|------|--------------|---|
| | | inverter heat sink temperature is higher than its set value, the cooling fan operates automatically regardless of its operation status. |
| 1 | Always On | Cooling fan runs constantly if the power is supplied to the inverter. |
| 2 | Temp Control | With power connected and the run operation command on: if the setting is in Temp Control, the cooling fan will not operate unless the temperature in the heat sink reaches the set temperature. |

Note

Despite setting ADV-64 to '0 (During Run)', if the heat sink temperature reaches a set level by current input harmonic wave or noise, the cooling fan may run as a protective function.

A capacity of 110 kW or more has a small built-in fan installed to cool the internal temperature. The internal fan controls on / off in conjunction with the operation command of the inverter main control fan

5.33 Input Power Frequency and Voltage Settings

Select the frequency for inverter input power. If the frequency changes from 60 Hz to 50 Hz, all other frequency (or RPM) settings, including the maximum frequency, base frequency, etc., will change to 50 Hz. Likewise, changing the input power frequency setting from 50 Hz to 60 Hz will change all related function item settings from 50 Hz to 60 Hz.

| Group | Code | Name | LCD Display | Parameter Setting | Setting Range | Unit |
|-------|------|-----------------------|--------------|-------------------|---------------|------|
| BAS | 10 | Input power frequency | 60/50 Hz Sel | 0 60 Hz | 0-1 | - |

Set Inverter input power voltage. Low voltage fault trip level changes automatically to the set voltage standard.

| Group | Code | Name | LCD Display | Parameter Setting | Setting Range | Unit | | |
|-------|------|---------------------|---------------|-------------------|---------------|---------|---|-----------|
| BAS | 19 | Input power voltage | AC Input Volt | 200 Type | 220 | 170-240 | V | |
| | | | | 400 Type | 380 | 320-480 | | 0.75~90kW |
| | | | | | | 320-550 | | 110~500kW |

5.34 Read, Write, and Save Parameters

Use read, write, and save function parameters on the inverter to copy parameters from the inverter to the keypad or from the keypad to the inverter.

| Group | Code | Name | LCD Display | Parameter Setting | | Setting Range | Unit |
|-------|------|-----------------|-----------------|-------------------|-----|---------------|------|
| CNF | 46 | Parameter read | Parameter Read | 1 | Yes | - | - |
| | 47 | Parameter write | Parameter Write | 1 | Yes | - | - |
| | 48 | Parameter save | Parameter Save | 1 | Yes | - | - |

Read, Write, and Save Parameter Setting Details

| Code | Description |
|------------------------|---|
| CNF-46 Parameter Read | Copies saved parameters from the inverter to the keypad. Saved parameters on the keypad will be deleted and replaced with the copied parameters. |
| CNF-47 Parameter Write | Copies saved parameters from the keypad to the inverter. Saved parameters on the inverter will be deleted and replaced with the copied parameters. If an error occurs during parameter writing, the previously saved data will be used. If there is no saved data on the Keypad, 'EEP Rom Empty' will be displayed. |
| CNF-48 Parameter Save | As parameters set during communication transmission are saved to RAM, the setting values will be lost if the power goes off and on. When setting parameters during communication transmission, select '1 (Yes)' at CNF-48 to save the set parameter. |

5.35 Parameter Initialization

User changes to parameters can be initialized (reset) to factory default settings on all or selected groups. However, during a fault trip situation or operation, parameters cannot be reset.

| Group | Code | Name | LCD Display | Parameter Setting | | Setting Range | Unit |
|-------|------|--------------------------|----------------|-------------------|----|---------------|------|
| CNF | 40 | Parameter initialization | Parameter Init | 0 | No | 0–15 | |

Parameter Initialization Setting Details

| Code | Description | | | |
|--------------------------|---------------------|-----------------------|-------------|---|
| CNF-40 Parameter Init | Setting | | LCD Display | Function |
| | 0 | No | No | - |
| | 1 | Initialize all groups | All Grp | Initialize all data. Select '1 (All Grp)' and press the [PROG/ENT] key to start initialization. On completion, '0 (No)' will be displayed. |
| | 2 | Initialize DRV group | DRV Grp | Initialize data by groups. Select initialize group and press the [PROG/ENT] key to start initialization. On completion, '0 (No)' will be displayed. |
| | 3 | Initialize BAS group | BAS Grp | |
| | 4 | Initialize ADV group | ADV Grp | |
| | 5 | Initialize CON group | CON Grp | |
| | 6 | Initialize IN group | IN Grp | |
| | 7 | Initialize OUT group | OUT Grp | |
| | 8 | Initialize COM group | COM Grp | |
| | 9 | Initialize PID group | PID Grp | |
| | 10 | Initialize EPI group | EPI Grp | |
| | 11 | Initialize AP1 group | AP1 Grp | |
| | 12 | Initialize AP2 group | AP2 Grp | |
| | 13 | Initialize AP3 group | AP3 Grp | |
| | 14 | Initialize PRT group | PRT Grp | |
| 15 | Initialize M2 group | M2 Grp | | |

5.36 Parameter View Lock

Use parameter view lock to hide parameters after registering and entering a user password.

| Group | Code | Name | LCD Display | Parameter Setting | Setting Range | Unit |
|-------|------|------------------------------|---------------|-------------------|---------------|------|
| CNF | 50 | Parameter view lock | View Lock Set | Un-locked | 0-9999 | |
| | 51 | Parameter view lock password | View Lock Pw | Password | 0-9999 | |

Parameter View Lock Setting Details

| Code | Description | | | | | | | | | | | | |
|----------------------|--|---|-----------|---|---|---|---|---|---|---|--------------------------|---|--|
| CNF-51 View Lock Pw | Register a password to allow access to parameter view lock. Follow the steps below to register a password. | | | | | | | | | | | | |
| | <table border="1"> <thead> <tr> <th>No</th> <th>Procedure</th> </tr> </thead> <tbody> <tr> <td>1</td> <td>[PROG/ENT] key on CNF-51 code will show the previous password input window. If registration is made for the first time, enter '0.' It is the factory default.</td> </tr> <tr> <td>2</td> <td>If a password had been set, enter the saved password.</td> </tr> <tr> <td>3</td> <td>If the entered password matches the saved password, a new window prompting the user to enter a new password will be displayed (the process will not progress to the next stage until the user enters a valid password).</td> </tr> <tr> <td>4</td> <td>Register a new password.</td> </tr> <tr> <td>5</td> <td>After registration, code CNF-51 will be displayed.</td> </tr> </tbody> </table> | No | Procedure | 1 | [PROG/ENT] key on CNF-51 code will show the previous password input window. If registration is made for the first time, enter '0.' It is the factory default. | 2 | If a password had been set, enter the saved password. | 3 | If the entered password matches the saved password, a new window prompting the user to enter a new password will be displayed (the process will not progress to the next stage until the user enters a valid password). | 4 | Register a new password. | 5 | After registration, code CNF-51 will be displayed. |
| | No | Procedure | | | | | | | | | | | |
| | 1 | [PROG/ENT] key on CNF-51 code will show the previous password input window. If registration is made for the first time, enter '0.' It is the factory default. | | | | | | | | | | | |
| | 2 | If a password had been set, enter the saved password. | | | | | | | | | | | |
| | 3 | If the entered password matches the saved password, a new window prompting the user to enter a new password will be displayed (the process will not progress to the next stage until the user enters a valid password). | | | | | | | | | | | |
| 4 | Register a new password. | | | | | | | | | | | | |
| 5 | After registration, code CNF-51 will be displayed. | | | | | | | | | | | | |
| | | | | | | | | | | | | | |
| | | | | | | | | | | | | | |
| | | | | | | | | | | | | | |
| | | | | | | | | | | | | | |
| CNF-50 View Lock Set | To enable parameter view lock, enter a registered password. The [Locked] sign will be displayed on the screen to indicate that parameter view lock is enabled. To disable parameter view lock, re-enter the password. The [locked] sign will disappear. | | | | | | | | | | | | |

5.37 Parameter Lock

Use parameter lock to prevent unauthorized modification of parameter settings. To enable parameter lock, register and enter a user password first.

| Group | Code | Name | LCD Display | Parameter Setting | Setting Range | Unit |
|-------|------|-------------------------|--------------|-------------------|---------------|------|
| CNF | 52 | Parameter lock | Key Lock Set | Un-locked | 0-9999 | - |
| | 53 | Parameter lock password | Key Lock Pw | Password | 0-9999 | - |

Parameter Lock Setting Details

| Code | Description | | | | | | | | | | | | |
|---------------------|--|--|------------|---|---|---|---|---|--|---|--------------------------|---|--|
| CNF-53 Key Lock PW | Register a password to prohibit parameter modifications. Follow the procedures below to register a password. | | | | | | | | | | | | |
| | <table border="1"> <thead> <tr> <th>No</th> <th>Procedures</th> </tr> </thead> <tbody> <tr> <td>1</td> <td>Press the [PROG/ENT] key on CNF-53 code and the saved password input window will be displayed. If password registration is being made for the first time, enter '0'. It is the factory default.</td> </tr> <tr> <td>2</td> <td>If a saved password has been set, enter the saved password.</td> </tr> <tr> <td>3</td> <td>If the entered password matches the saved password, then a new window to enter a new password will be displayed. (The process will not move to next stage until the user enters a valid password).</td> </tr> <tr> <td>4</td> <td>Register a new password.</td> </tr> <tr> <td>5</td> <td>After registration, Code CNF-53 will be displayed.</td> </tr> </tbody> </table> | No | Procedures | 1 | Press the [PROG/ENT] key on CNF-53 code and the saved password input window will be displayed. If password registration is being made for the first time, enter '0'. It is the factory default. | 2 | If a saved password has been set, enter the saved password. | 3 | If the entered password matches the saved password, then a new window to enter a new password will be displayed. (The process will not move to next stage until the user enters a valid password). | 4 | Register a new password. | 5 | After registration, Code CNF-53 will be displayed. |
| | No | Procedures | | | | | | | | | | | |
| | 1 | Press the [PROG/ENT] key on CNF-53 code and the saved password input window will be displayed. If password registration is being made for the first time, enter '0'. It is the factory default. | | | | | | | | | | | |
| | 2 | If a saved password has been set, enter the saved password. | | | | | | | | | | | |
| | 3 | If the entered password matches the saved password, then a new window to enter a new password will be displayed. (The process will not move to next stage until the user enters a valid password). | | | | | | | | | | | |
| 4 | Register a new password. | | | | | | | | | | | | |
| 5 | After registration, Code CNF-53 will be displayed. | | | | | | | | | | | | |
| CNF-52 Key Lock Set | To enable parameter lock, enter the registered password. The [Locked] sign will be displayed on the screen to indicate that prohibition is enabled. Once enabled, pressing the [PROG/ENT] key at once function code will not allow the display edit mode to run. To disable parameter modification prohibition, re-enter the password. The [Locked] sign will disappear. | | | | | | | | | | | | |

⚠ Caution

If parameter view lock and parameter lock functions are enabled, no inverter operation related function changes can be made. It is very important that you memorize the password.

5.38 Changed Parameter Display

This feature displays all the parameters that are different from the factory defaults. Use this feature to track changed parameters.

| Group | Code | Name | LCD Display | Parameter Setting | | Setting Range | Unit |
|-------|------|---------------------------|--------------|-------------------|----------|---------------|------|
| CNF | 41 | Changed parameter display | Changed Para | 0 | View All | - | - |

Changed Parameter Display Setting Details

| Code | Description | | |
|------------------------|-------------|----------|------------------------|
| CNF-41 Changed Para | Setting | Function | |
| | 0 | View All | Display all parameters |

| Code | | Description |
|------|--------------|---------------------------------|
| 1 | View Changed | Display changed parameters only |

5.39 User Group

Create a user defined group and register user-selected parameters from the existing function groups. The user group can carry up to a maximum of 64 parameter registrations.

| Group | Code | Name | LCD Display | Parameter Setting | Setting Range | Unit |
|-------|------|----------------------------------|----------------|-------------------|----------------|------|
| CNF | 42 | Multi-function key settings | Multi Key Sel | 3 | UserGrp SelKey | - |
| | 45 | Delete all user registered codes | UserGrp AllDel | 0 | No | - |

User Group Setting Details

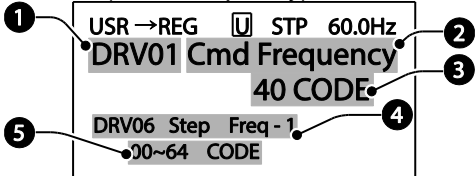
| Code | Description | | | | | | |
|---|---|---|-----------|---|---|---|--|
| CNF-42 Multi Key Sel | <p>Select 3 (UserGrp SelKey) from the multi-function key setting options. If user group parameters are not registered, setting the multi-function key to the user group select key (UserGrp SelKey) will not display user group (USR Grp) items on the Keypad. Follow the procedures below to register parameters to a user group.</p> <table border="1"> <thead> <tr> <th>No</th> <th>Procedure</th> </tr> </thead> <tbody> <tr> <td>1</td> <td>Set CNF- 42 to '3 (UserGrp SelKey)'. A U icon will be displayed at the top of the LCD display.</td> </tr> <tr> <td>2</td> <td>In the parameter mode (PAR Mode), move to the parameter you need to register and press the [MULTI] key. For example, if the [MULTI] key is pressed in the frequency reference in DRV-01 (Cmd Frequency), the screen below will be displayed.</td> </tr> </tbody> </table> | No | Procedure | 1 | Set CNF- 42 to '3 (UserGrp SelKey)'. A U icon will be displayed at the top of the LCD display. | 2 | In the parameter mode (PAR Mode), move to the parameter you need to register and press the [MULTI] key. For example, if the [MULTI] key is pressed in the frequency reference in DRV-01 (Cmd Frequency), the screen below will be displayed. |
| | No | Procedure | | | | | |
| | 1 | Set CNF- 42 to '3 (UserGrp SelKey)'. A U icon will be displayed at the top of the LCD display. | | | | | |
| 2 | In the parameter mode (PAR Mode), move to the parameter you need to register and press the [MULTI] key. For example, if the [MULTI] key is pressed in the frequency reference in DRV-01 (Cmd Frequency), the screen below will be displayed. | | | | | | |
|  <p> 1 Group name and code number of the parameter 2 Name of the parameter 3 Code number to be used in the user group. Pressing the [PROG/ENT] key on the code number (40 Code) will register DRV-01 as code 40 in the user group. </p> | | | | | | | |

| Code | Description |
|--|---|
| | <p>④ Existing parameter registered as the user group code 40</p> <p>⑤ Setting range of the user group code. Entering '0' cancels the settings.</p> |
| 3 | <p>③ Set a code number to use to register the parameter in the user group. Select the code number and press the [PROG/ENT] key.</p> |
| 4 | <p>Changing the value in ③ will also change the value in ④. If no code is registered, 'Empty Code' will be displayed. Entering '0' cancels the settings.</p> |
| 5 | <p>The registered parameters are listed in the user group in U&M mode. You can register one parameter multiple times if necessary. For example, a parameter can be registered as code 2, code 11, and more in the user group.</p> |
| <p>Follow the procedures below to delete parameters in the user group.</p> | |
| No. | Settings |
| 1 | Set CNF- 42 to '3 (UserGrp SelKey)'. A  icon will be displayed at the top of the LCD display. |
| 2 | In the USR group in U&M mode, move the cursor to the code that is to be deleted. |
| 3 | Press the [MULTI] key. |
| 4 | Move to 'YES' on the deletion confirmation screen, and press the [PROG/ENT] key. |
| 5 | Deletion completed. |
| CNF-25 UserGrp AllDel | Set to '1 (Yes)' to delete all registered parameters in the user group. |

5.40 Easy Start On

Run Easy Start On to easily setup the basic motor parameters required to operate a motor in a batch. Set CNF-61 (Easy Start On) to '1 (Yes)' to activate the feature, initialize all parameters by setting CNF-40 (Parameter Init) to '1 (All Grp)', and restart the inverter to activate Easy Start On.

| Group | Code | Name | LCD Display | Parameter Setting | Setting Range | Unit |
|-------|------|-------------------------------|---------------|-------------------|---------------|------|
| CNF | 61 | Parameter easy start settings | Easy Start On | 1 Yes | - | - |

Easy Start On Setting Details

| Code | Description | | | | | | | | |
|----------------------------|--|---|------------|---|---|---|--|---|---|
| CNF-61 Easy Start On | Follow the procedures listed below to set the easy start on parameters. | | | | | | | | |
| | <table border="1"> <thead> <tr> <th>No</th> <th>Procedures</th> </tr> </thead> <tbody> <tr> <td>1</td> <td>Set CNF-61 (Easy Start On) to '1(Yes)'.</td> </tr> <tr> <td>2</td> <td>Select '1 (All Grp)' in CNF-40 (Parameter Init) to initialize all parameters</td> </tr> <tr> <td>3</td> <td> <p>Restarting the inverter will activate Easy Start On. Set the values in the following screens on the Keypad. To escape from Easy Start On, press the [ESC] key.</p> <ul style="list-style-type: none"> Start Easy Set: Select 'Yes'. CNF-43: Select a macro. BAS-10 60/50 Hz Sel: Set motor rated frequency. DRV-14 Motor Capacity: Set motor capacity. BAS-13 Rated Curr: Set motor rated current. BAS-15 Rated Volt: Set motor rated voltage. BAS-11 Pole Number: Set motor pole number. BAS-19 AC Input Volt: Set input voltage. PRT-08 Select start at trip reset PRT-09 Retry Number: Sets the number of restart trial when performing a trip reset. COM-96 PowerOn Resume: Sets the serial communication restart function. CON-71 SpeedSearch: Set SpeedSearch. DRV-06 Cmd Source: Set command source. DRV-07 Freq Ref Src: Set Frequency Reference source. AP3-01 Now Date : Set the current date. AP3-02 Now Time : Set the current time. <p>When the settings are complete, the minimum parameter settings on the motor have been made. The Keypad will return to a monitoring display. Now the motor can be operated with the command source set at DRV-06.</p> </td> </tr> </tbody> </table> | No | Procedures | 1 | Set CNF-61 (Easy Start On) to '1(Yes)'. | 2 | Select '1 (All Grp)' in CNF-40 (Parameter Init) to initialize all parameters | 3 | <p>Restarting the inverter will activate Easy Start On. Set the values in the following screens on the Keypad. To escape from Easy Start On, press the [ESC] key.</p> <ul style="list-style-type: none"> Start Easy Set: Select 'Yes'. CNF-43: Select a macro. BAS-10 60/50 Hz Sel: Set motor rated frequency. DRV-14 Motor Capacity: Set motor capacity. BAS-13 Rated Curr: Set motor rated current. BAS-15 Rated Volt: Set motor rated voltage. BAS-11 Pole Number: Set motor pole number. BAS-19 AC Input Volt: Set input voltage. PRT-08 Select start at trip reset PRT-09 Retry Number: Sets the number of restart trial when performing a trip reset. COM-96 PowerOn Resume: Sets the serial communication restart function. CON-71 SpeedSearch: Set SpeedSearch. DRV-06 Cmd Source: Set command source. DRV-07 Freq Ref Src: Set Frequency Reference source. AP3-01 Now Date : Set the current date. AP3-02 Now Time : Set the current time. <p>When the settings are complete, the minimum parameter settings on the motor have been made. The Keypad will return to a monitoring display. Now the motor can be operated with the command source set at DRV-06.</p> |
| | No | Procedures | | | | | | | |
| | 1 | Set CNF-61 (Easy Start On) to '1(Yes)'. | | | | | | | |
| 2 | Select '1 (All Grp)' in CNF-40 (Parameter Init) to initialize all parameters | | | | | | | | |
| 3 | <p>Restarting the inverter will activate Easy Start On. Set the values in the following screens on the Keypad. To escape from Easy Start On, press the [ESC] key.</p> <ul style="list-style-type: none"> Start Easy Set: Select 'Yes'. CNF-43: Select a macro. BAS-10 60/50 Hz Sel: Set motor rated frequency. DRV-14 Motor Capacity: Set motor capacity. BAS-13 Rated Curr: Set motor rated current. BAS-15 Rated Volt: Set motor rated voltage. BAS-11 Pole Number: Set motor pole number. BAS-19 AC Input Volt: Set input voltage. PRT-08 Select start at trip reset PRT-09 Retry Number: Sets the number of restart trial when performing a trip reset. COM-96 PowerOn Resume: Sets the serial communication restart function. CON-71 SpeedSearch: Set SpeedSearch. DRV-06 Cmd Source: Set command source. DRV-07 Freq Ref Src: Set Frequency Reference source. AP3-01 Now Date : Set the current date. AP3-02 Now Time : Set the current time. <p>When the settings are complete, the minimum parameter settings on the motor have been made. The Keypad will return to a monitoring display. Now the motor can be operated with the command source set at DRV-06.</p> | | | | | | | | |

⚠ Caution

Use caution when turning on the inverter after Easy Start On configuration. If codes such as PRT-08 (Reset Restart), COM-96 (PowerOn Resume), or CON-71 (SpeedSearch) are configured in Easy Start On, the inverter may start operating as soon as it is powered on.

5.41 Config (CNF) Mode

The config mode parameters are used to configure keypad related features.

| Group | Code | Name | LCD Display | Parameter Setting | Setting Range | Unit |
|-------|-------|--|----------------|-------------------|---------------|------|
| CNF* | 2 | LCD brightness/contrast adjustment | LCD Contrast | - | - | |
| | 10 | Inverter S/W version | Inv S/W Ver | x.xx | - | |
| | 11 | Keypad S/W version | Keypad S/W Ver | x.xx | - | - |
| | 12 | Keypad title version | KPD Title Ver | x.xx | - | - |
| | 30–32 | Power slot type | Option-x Type | None | - | - |
| | 44 | Erase trip history | Erase All Trip | No | - | - |
| | 60 | Add title update | Add Title Up | No | - | - |
| | 62 | Initialize accumulated electric energy | WH Count Reset | No | - | - |

Config Mode Parameter Setting Details

| Code | Description |
|--|--|
| CNF-2 LCD Contrast | Adjusts LCD brightness/contrast on the keypad. |
| CNF-10 Inv SW Ver, CNF-11 Keypad SW Ver | Checks the OS version in the inverter and on the keypad. |
| CNF-12 KPD Title Ver | Checks the title version on the keypad. |
| CNF-30–32 Option-x Type | Checks the type of option board installed in the option slot. The H100 inverters use type-1 option boards only (CNF-30 Option-1 Type). CNF-31 and CNF-32 are not used. |
| CNF-44 Erase All Trip | Deletes the stored trip history. |
| CNF-60 Add Title Up | When inverter SW version is updated and more code is added, CNF-60 settings will add, display, and operate the added codes. Set CNF-60 to '1 (Yes)' and disconnect the keypad from the inverter. Reconnecting the keypad to the inverter updates titles. |
| CNF-62 WH Count Reset | Initialize the accumulated electric energy consumption count. |

5.42 Macro Selection

The Macro selection function is used to put various application functions together in a group. For applications with the H100 series inverters, 7 basic Macro configurations are currently available. Macro functions cannot be added by the user, but the data can be modified.

| Group | Code | Name | LCD Display | Parameter Setting | | Setting Range | Unit |
|-------|------|-----------------|--------------|-------------------|---------------|---------------|------|
| CNF | 43 | Macro selection | Macro Select | 0 | Basic | 0–7 | - |
| | | | | 1 | Compressor | | |
| | | | | 2 | Supply Fan | | |
| | | | | 3 | Exhaust Fan | | |
| | | | | 4 | Cooling Tower | | |
| | | | | 5 | Circul. Pump | | |
| | | | | 6 | Vacuum Pump | | |
| | | | | 7 | Constant Torq | | |

Macro Selection Details

| Code | Description |
|---------------------|--|
| CNF-43 Macro Select | A list of Macro settings is displayed for user selection. When a Macro function is selected, all the related parameters are automatically changed based on the inverter's Macro settings. If '0 (Basic)' is selected, all the inverter parameters, including the parameters controlled by the Macro function, are initialized. For other macro application settings (settings 1–7), refer to 5.42 Macro Selection on page 254. |

5.43 Timer Settings

Set a multi-function input terminal to a timer. Sets the On/Off controls to the multi-function outputs and relays according to the timer settings.

| Group | Code | Name | LCD Display | Parameter Setting | | Setting Range | Unit |
|-------|-------|---------------------------|-----------------------|-------------------|-----------|---------------|------|
| IN | 65–71 | Px terminal configuration | Px Define (Px: P1–P7) | 35 | Timer In | 0-55 | - |
| OUT | 31 | Multi-function relay 1 | Relay 1 | 22 | Timer Out | 0-41 | - |
| | 33 | Multi-function output 1 | Q1 Define | | | | |
| | 55 | Timer on delay | TimerOn Delay | 3.00 | | 0.00–100.00 | sec |
| | 56 | Timer off delay | TimerOff Delay | 1.00 | | 0.00–100.00 | sec |

Timer Setting Details

| Code | Description |
|---|--|
| IN-65–71 Px Define | Choose one of the multi-function input terminals and change it to a timer terminal by setting it to '35(Timer In)'. |
| OUT-31 Relay 1, OUT-36 Q1 Define | Set the multi-function output terminal or relay to be used as a timer to '22 (Timer out)'. |
| OUT-55 TimerOn Delay, OUT-56 TimerOff Delay | Input a signal (On) to the timer terminal to operate a timer output (Timer out) after the time set at OUT-55 has passed. When the multi-function input terminal is off, the multi-function output or relay turns off after the time set at OUT-56. |

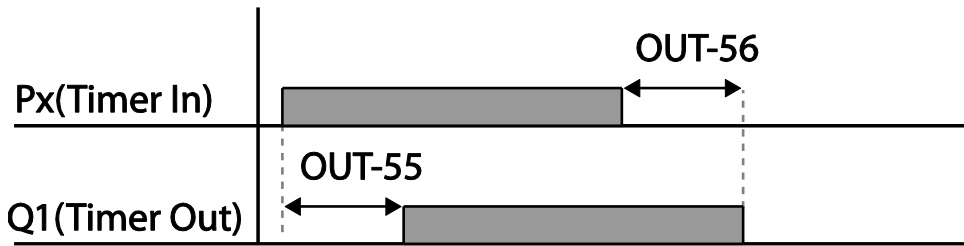

5.44 Multiple Motor Control (MMC)

The MMC (Multiple Motor Control) function is used to control multiple motors for a pump system. The main motor connected with the inverter output is controlled by the PID controller. The auxiliary motors are connected with the supply power and turned on and off by the relay within the inverter.

| Group | Code | Name | LCD Display | Parameter Setting | Setting Range | Unit | |
|-----------------|-----------|----------------------------|--------------|-------------------|------------------------------|----------------|---|
| AP1 | 40 | MMC function selection | MMC Sel | 0: None | 0 | None | - |
| | | | | | 1 | Single Ctrl | |
| | | | | | 2 | Multi Follower | |
| | | | | | 3 | Multi Master | |
| | | | | | 4 ¹ | Serve Drv | |
| | 41 | Bypass selection | Regul Bypass | 0: No | 0 | No | - |
| | | | | | 1 | Yes | |
| | 42 | Number of auxiliary motors | Num of Aux | 5 | 1 – AuxMaxMotor ² | - | |
| 43 ³ | Auxiliary | Starting Aux | 1 | 1–5 | - | | |

¹ AP1-47~87 and AP1-91~98 are not displayed when AP1-40 is set to '4(Serve Drv)'.

² If Extension IO option is equipped or AP1-40 is set to '2 or 3', AuxMaxMotor is set to '8'. Otherwise AuxMaxMotor is set to '5'.

³ If AP1-49 is set to '2(Op Time Order)', the parameter cannot be set by a user and it is

| Group | Code | Name | LCD Display | Parameter Setting | Setting Range | Unit | |
|-------|------|--|-------------------|-------------------|---------------|---------------|---|
| | | starting motor selection | | | | | |
| | 44 | Number of operating auxiliary motors | Aux Motor Run | - | - | - | |
| | 45 | Auxiliary motor (#1– 4) priority | Aux Priority 1 | - | - | - | |
| | 46 | Auxiliary motor (#5– 8) priority | Aux Priority 2 | - | - | - | |
| | 48 | Auxiliary motor operation at stop | Aux All Stop | 0: No | 0 | No | - |
| | | | | | 1 | Yes | |
| | 49 | Stop order for auxiliary motors | FIFO/FILO | 0: FILO | 0 | FILO | - |
| | | | | | 1 | FIFO | |
| | | | | | 2 | Op Time Order | |
| | 50 | Auxiliary motor pressure difference | Actual Start Diff | 2 | 0–100 | Unit | |
| | 51 | Main motor acceleration time when auxiliary motor # is reduced | Aux Acc Time | 2 | 0–600.0 | Sec | |
| | 52 | Main motor deceleration time when auxiliary motor is added | Aux Dec Time | 2 | 0–600.0 | Sec | |
| | 53 | Auxiliary motor start delay time | Aux Start DT | 5 | 0.0–999.9 | Sec | |
| | 54 | Auxiliary motor stop delay time | Aux Stop DT | 5 | 0.0–999.9 | Sec | |
| | 55 | Auto change | Auto Ch | 0: None | 0 None | - | |

automatically changed as the operation time of aux motors.

Learning Advanced Features

| Group | Code | Name | LCD Display | Parameter Setting | Setting Range | Unit |
|-------|-----------------|---|---------------|-------------------|-----------------------------------|------|
| | | mode selection | Mode | | 1 AUX Exchange 2 MAIN Exchange | |
| | 56 | Auto change time | Auto Ch Time | 72: 00 | 00: 00–99: 00 | Min |
| | 57 | Auto change frequency | Auto Ch Level | 20.00 | Low Freq–High Freq | Hz |
| | 58 | Auto change operation time | Auto Op Time | - | - | - |
| | 59 | Auxiliary motor pressure difference | Aux Stop Diff | 2 | 0~100 | Unit |
| | 60 | Target frequency of Aux Motor while Multi Master is operating | Follower Freq | 60.00 | Low Freq~ High Freq | Hz |
| | 61 | #1 auxiliary motor start frequency | Start Freq 1 | 45 | Low Freq–High Freq | Hz |
| | 62 | #2 auxiliary motor start frequency | Start Freq 2 | 45 | Low Freq–High Freq | Hz |
| | 63 | #3 auxiliary motor start frequency | Start Freq 3 | 45 | Low Freq–High Freq | Hz |
| | 64 | #4 auxiliary motor start frequency | Start Freq 4 | 45 | Low Freq–High Freq | Hz |
| | 65 | #5 auxiliary motor start frequency | Start Freq 5 | 45 | Low Freq–High Freq | Hz |
| | 66 ⁴ | #6 auxiliary | Start Freq 6 | 45 | Low Freq–High | Hz |

⁴ AP1-66~68 , AP1-75~77 and AP1-85~87 are displayed when Extension IO option is equipped or AP1-40 is set to '2 or 3'.

| Group | Code | Name | LCD Display | Parameter Setting | Setting Range | Unit |
|-------|------|---|---------------|-------------------|--------------------|------|
| | | motor start frequency | | | Freq | |
| | 67 | #7 auxiliary motor start frequency | Start Freq 7 | 45 | Low Freq–High Freq | Hz |
| | 68 | #8 auxiliary motor start frequency | Start Freq 8 | 45 | Low Freq–High Freq | Hz |
| | 70 | #1 auxiliary motor stop frequency | Stop Freq 1 | 20 | Low Freq–High Freq | Hz |
| | 71 | #2 auxiliary motor stop frequency | Stop Freq 2 | 20 | Low Freq–High Freq | Hz |
| | 72 | #3 auxiliary motor stop frequency | Stop Freq 3 | 20 | Low Freq–High Freq | Hz |
| | 73 | #4 auxiliary motor stop frequency | Stop Freq 4 | 20 | Low Freq–High Freq | Hz |
| | 74 | #5 auxiliary motor stop frequency | Stop Freq 5 | 20 | Low Freq–High Freq | Hz |
| | 75 | #6 auxiliary motor stop frequency | Stop Freq 6 | 20 | Low Freq–High Freq | Hz |
| | 76 | #7 auxiliary motor stop frequency | Stop Freq 7 | 20 | Low Freq–High Freq | Hz |
| | 77 | #8 auxiliary motor stop frequency | Stop Freq 8 | 20 | Low Freq–High Freq | Hz |
| | 80 | #1 auxiliary motor reference compensation | Aux1 Ref Comp | 0 | 0–Unit Band | Unit |
| | 81 | #2 auxiliary motor reference compensation | Aux2 Ref Comp | 0 | 0–Unit Band | Unit |

Learning Advanced Features

| Group | Code | Name | LCD Display | Parameter Setting | Setting Range | Unit | |
|-------|-----------------|--|----------------|-------------------|---------------|-------|---|
| | 82 | #3 auxiliary motor reference compensation | Aux3 Ref Comp | 0 | 0–Unit Band | Unit | |
| | 83 | #4 auxiliary motor reference compensation | Aux4 Ref Comp | 0 | 0–Unit Band | Unit | |
| | 84 | #5 auxiliary motor reference compensation | Aux5 Ref Comp | 0 | 0–Unit Band | Unit | |
| | 85 | #6 auxiliary motor reference compensation | Aux6 Ref Comp | 0 | 0–Unit Band | Unit | |
| | 86 | #7 auxiliary motor reference compensation | Aux7 Ref Comp | 0 | 0–Unit Band | Unit | |
| | 87 | #8 auxiliary motor reference compensation | Aux8 Ref Comp | 0 | 0–Unit Band | Unit | |
| | 90 | Interlock selection | Interlock | 0: No | 0 | No | - |
| | | | | | 1 | Yes | |
| | 91 | Delay time before an operation for the next motor when an interlock or an auto change on the main motor occur. | Interlock DT | 5.0 | 0–360.0 | Sec | |
| | 95 ⁵ | Selecting auxiliary motor to indicate in [AP1-96] [AP1-97]. | AuxRunTime Sel | | 0 | Aux 1 | |
| | | | | | 1 | Aux 2 | |
| | | | | | 2 | Aux 3 | |
| | | | | | 3 | Aux 4 | |
| | | | | | 4 | Aux 5 | |

⁵ AP1-95~98 are available when MMC and Master Follower functions are performed.

| Group | Code | Name | LCD Display | Parameter Setting | Setting Range | | Unit | |
|-------|-------|------|--|-------------------|----------------|---------------|------|--|
| | | | | | 5 ⁶ | Aux 6 | | |
| | | | | | 6 | Aux 7 | | |
| | | | | | 7 | Aux 8 | | |
| | | 96 | Operating time(Day) of auxiliary motor chosen in [AP1-95]. | AuxRunTime Day | 0 | 0~65535 | | |
| | | 97 | Operating time of auxiliary motor chosen in [AP1-95]. | AuxRunTime Min | 00:00 | 00:00 ~ 23:59 | | |
| | | 98 | Deleting operating time of auxiliary motor. | AuxRunTime Clr | | 0 | None | |
| | 1 | | | | | All | | |
| | 2 | | | | | Aux 1 | | |
| | 3 | | | | | Aux 2 | | |
| | 4 | | | | | Aux 3 | | |
| 5 | Aux 4 | | | | | | | |
| 6 | Aux 5 | | | | | | | |
| 7 | Aux 6 | | | | | | | |
| | | | | | 8 | Aux 7 | | |
| | | | | | 9 | Aux 8 | | |

⁶ '5(Aux6)~7(Aux8)' of AP1-95 and '7(Aux6)~9(Aux8)' of AP1-98 and displayed when Extension IO option is equipped or AP1-40 is set to '2 or 3'.

MMC Setting Details

| Code | Description | | | | | | | | |
|---|---|---|---|---|---|---|---|---|---|
| AP1-40 MMC Sel | <p>Selects the MMC operation settings.</p> <ul style="list-style-type: none"> -None : Deactivates MMC function -Single Ctrl : Activates general MMC function -Multi Follower : Activates Master Follower as Multi Follower mode -Multi Master: Activates Master Follower as Multi Master mode -Serve Drv: Sets Serve Drv used at Master Follower. | | | | | | | | |
| AP1-42 Num of Aux | Decides the number of auxiliary motors to use. | | | | | | | | |
| AP1-43 Starting Aux | Sets the start auxiliary motor. | | | | | | | | |
| AP1-44 Aux Motor Run | Indicates the number of the operating auxiliary motors. | | | | | | | | |
| AP1-45–46 Aux Priority1–2 | <p>Indicates the operating priority of auxiliary motors. According to setting by users, it can be influenced by Interlock, AutoChange and operating time</p> <p>Each four-digit numbers for the parameter mean the auxiliary motor numbers and indicate the priority of auxiliary motors. In other words, the most right number of [AP1-45 Aux Priority1] indicates the priority of Auxiliary motor 1 and the second number from the right of [AP1-45 Aux Priority1] indicates the priority of Auxiliary motor 2.</p> <div style="display: flex; justify-content: space-around; align-items: flex-end;"> <div style="text-align: center;"> <p>[AP1-45 Aux Priority1]</p> <table border="1" style="margin: 0 auto;"> <tr> <td style="padding: 2px 10px;">x</td> <td style="padding: 2px 10px;">x</td> <td style="padding: 2px 10px;">x</td> <td style="padding: 2px 10px;">x</td> </tr> </table> <p style="font-size: small;">↑ ↑ ↑ ↑</p> <p style="font-size: x-small;">The Priority of the Aux motor4 ••• The Priority of the Aux motor1</p> </div> <div style="text-align: center;"> <p>[AP1-46 Aux Priority2]</p> <table border="1" style="margin: 0 auto;"> <tr> <td style="padding: 2px 10px;">x</td> <td style="padding: 2px 10px;">x</td> <td style="padding: 2px 10px;">x</td> <td style="padding: 2px 10px;">x</td> </tr> </table> <p style="font-size: small;">↑ ↑ ↑ ↑</p> <p style="font-size: x-small;">The Priority of the Aux motor8 ••• The Priority of the Aux motor5</p> </div> </div> | x | x | x | x | x | x | x | x |
| x | x | x | x | | | | | | |
| x | x | x | x | | | | | | |
| AP1-48 Aux All Stop | <p>When [AP1-48 Aux All Stop] is set to “No” during input to stop operating, auxiliary motors are turned off at the same time.</p> <p>When [AP1-48 Aux All Stop] is set to “YES”, auxiliary motors are turned off gradually based on time of [AP1-54 Aux Stop DT].</p> | | | | | | | | |
| AP1-49 FIFO/FILO | <p>Sets the operating priority of MMC.</p> <p>FIFO : Same as On/Off order of auxiliary motors.</p> <p>FILO: Opposite to On/Off order auxiliary motors.</p> <p>Op Time Order : setting automatically according to operating time of auxiliary motors.</p> | | | | | | | | |
| AP1-50 Aux Start Diff AP1-59 Aux Stop Diff | <p>One of the conditions to turn on and off the next auxiliary motors. Parameters to set the difference when the difference between the reference and feedback is more than regular value</p> | | | | | | | | |

| | |
|---|--|
| <p>AP1-51 Acc Time AP1-52 Dec Time</p> | <p>Parameters used when AP1-40 is set to 'Single Ctrl' When an auxiliary motor starts or stops, the main motor stops the PID control, and performs general acceleration and deceleration. When an auxiliary motor starts, the main motor decelerates to the auxiliary motor deceleration frequency set at AP1-70–74 (Stop Freq 1–5) based on the deceleration time set at AP1-52 (Dec Time). When the auxiliary motor stops, the main motor accelerates up to the auxiliary motor restart frequency set at AP1-61–65 (Start Freq 1–5) based on the acceleration time set at AP1-51 (Acc Time).</p> |
| <p>AP1-53 Aux Start DT AP1-54 Aux Stop DT</p> | <p>The auxiliary motors turns on or off after the auxiliary motor stop delay time or the auxiliary motor restart delay time elapses, or if the difference between the current reference and the feedback is greater than the value set at AP1-50 (Actual Pr Diff).</p> |
| <p>AP1-61–65 Start Freq1–5</p> | <p>Sets the auxiliary motor start frequency.</p> |
| <p>AP1-70–74 Stop Freq 1–5</p> | <p>Sets the auxiliary motor stop frequency.</p> |
| <p>AP1-95 AuxRunTime Sel</p> | <p>Selects auxiliary motor to be used in AP1-96 and AP1-97.</p> |
| <p>AP1-96 AuxRunTime Day</p> | <p>Indicates operating time(day) selected in AP1-95.</p> |
| <p>AP1-97 AuxRunTime Min</p> | <p>Indicates operating time of auxiliary motors selected in AP1-95.</p> |
| <p>AP1-98 AuxRunTime Clr</p> | <p>Deletes operating time of auxiliary motors.</p> |
| <p>OUT-31–35 Relay 1–5 OUT-36 Q1 Define</p> | <p>Configure the output terminals to '21 (MMC)' to use the terminals to control the auxiliary motors. The number of the configured output terminals determines the total number of auxiliary motors to be used.</p> |

5.44.1 Multiple Motor Control (MMC) Basic Sequence

Multiple motor control (MMC) is an operation based on PID control. During an MMC operation, the main and auxiliary motors organically operate together.

During a PID operation, the auxiliary motors are turned on when the inverter frequency reaches the start frequencies set at AP1-61–65 (Start freq), and the difference between the PID reference and feedback is bigger than the value set at AP1-50. Then, the auxiliary motors stop operating when the operation frequency reach the stop frequency set at AP1-70–74 (Stop Freq 1–5) and the difference between the PID feedback and reference becomes greater than the value set at AP1-50.

| Group | Code | Name | LCD Display | Parameter Setting | Setting Range | Unit |
|-------|-------|--------------------------------------|----------------|-----------------------------------|--------------------|------|
| AP1 | 61–65 | #1–5 auxiliary motor start frequency | Start Freq 1–5 | Frequency value within the range | Low Freq–High Freq | Hz |
| | 50 | Auxiliary motors pressure difference | Actual Pr Diff | Percentage value within the range | 0–100 (%) | % |
| | 70–74 | #1–5 auxiliary motor stop frequency | Stop Freq 1–5 | Frequency value within the range | Low Freq–High Freq | Hz |

The following diagram describes the MMC basic sequence based on FILO and FIFO settings.

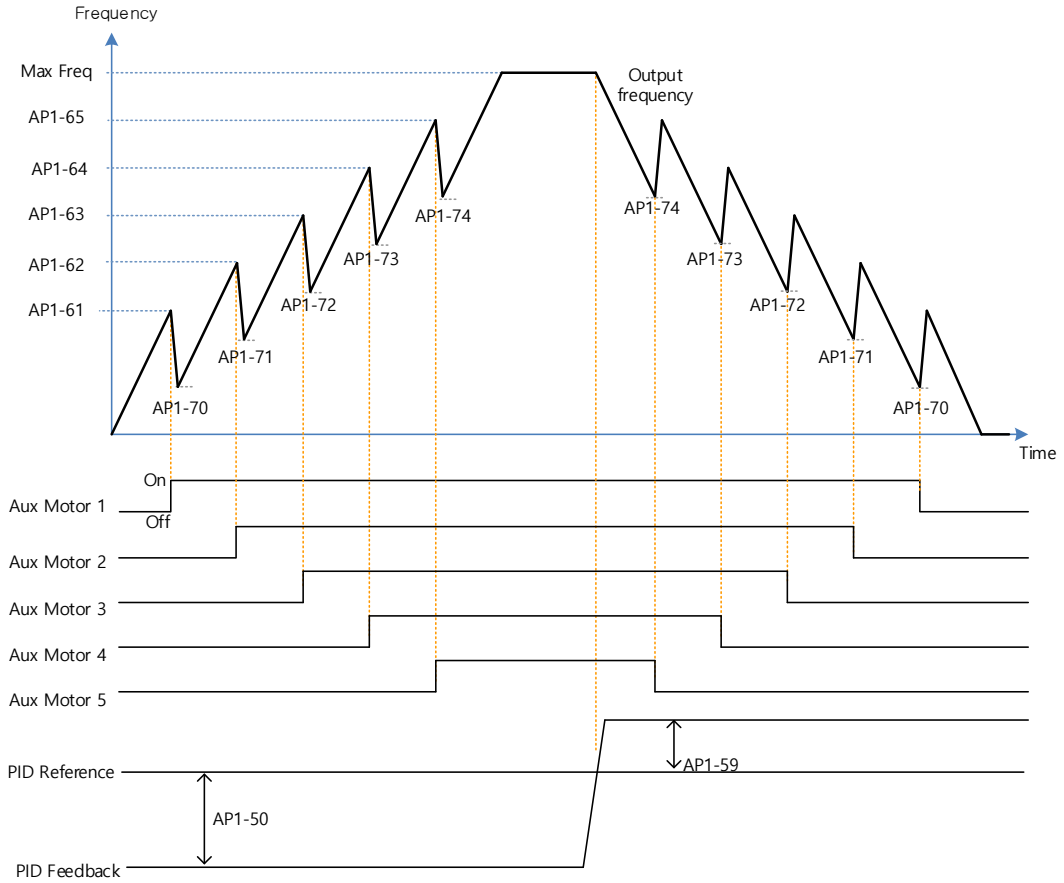

MMC Basic operation(FILO)

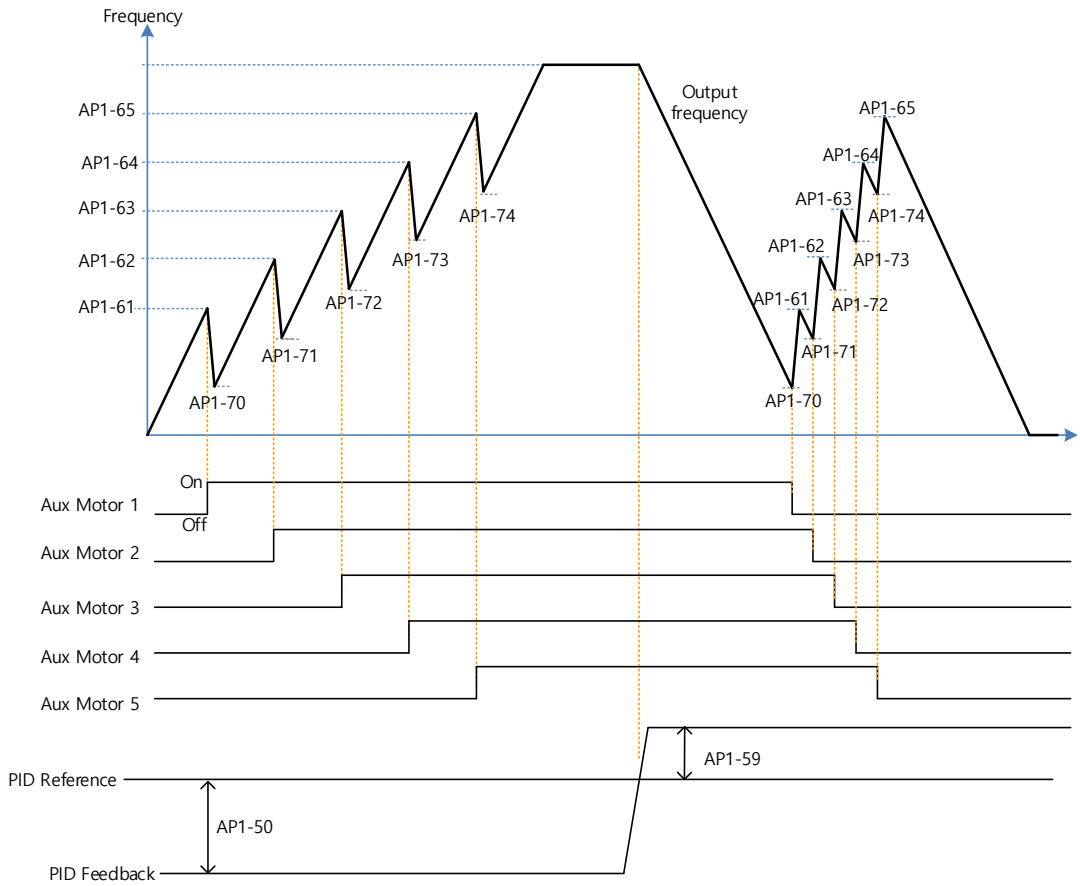

MMC Basic operation(FIFO)

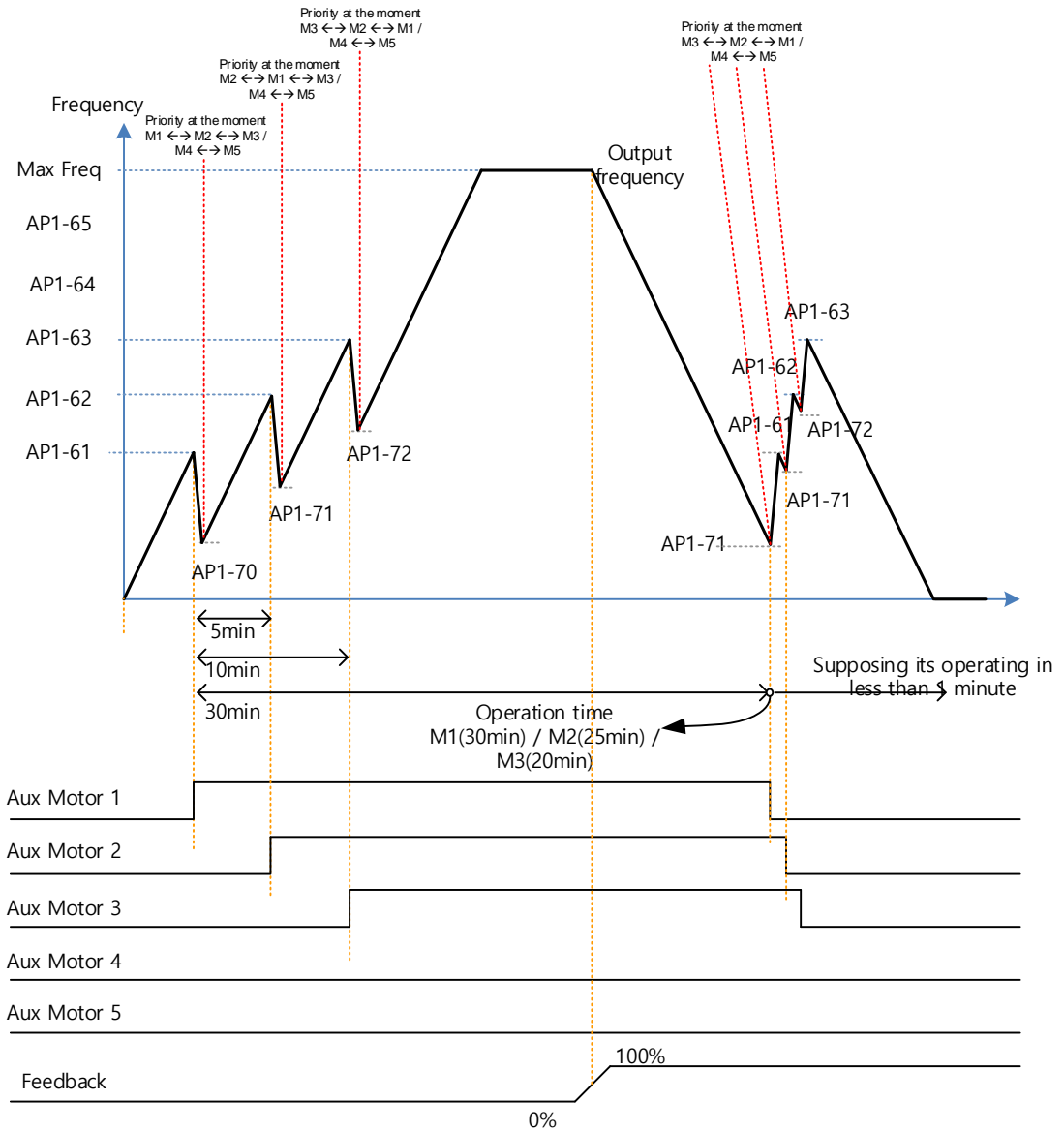

MMC Basic operation(OP Time Order)

The following diagram is an operation graph based on the start and stop delay times set at AP1-53 (Aux start DT) and AP1-54 (Aux stop DT). When the start or stop frequencies are reached, the auxiliary motor waits for the time set at AP1-53 (Aux start DT) or AP1-54 (Aux stop DT) before it starts or stops.

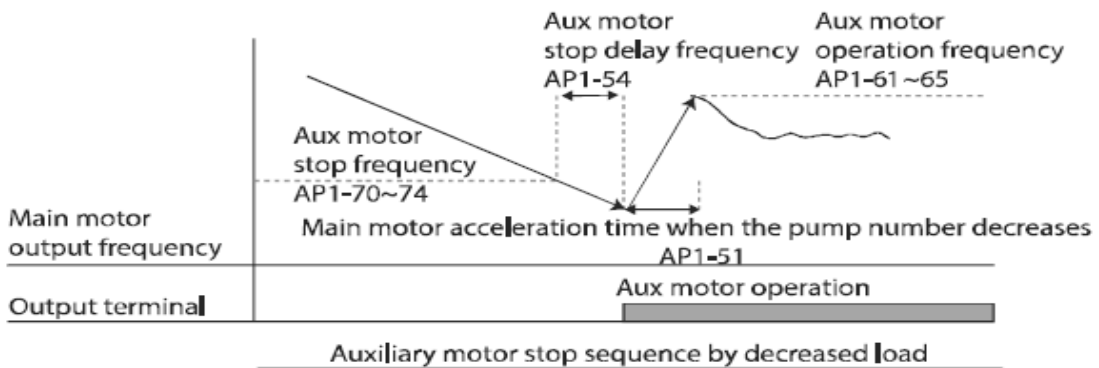
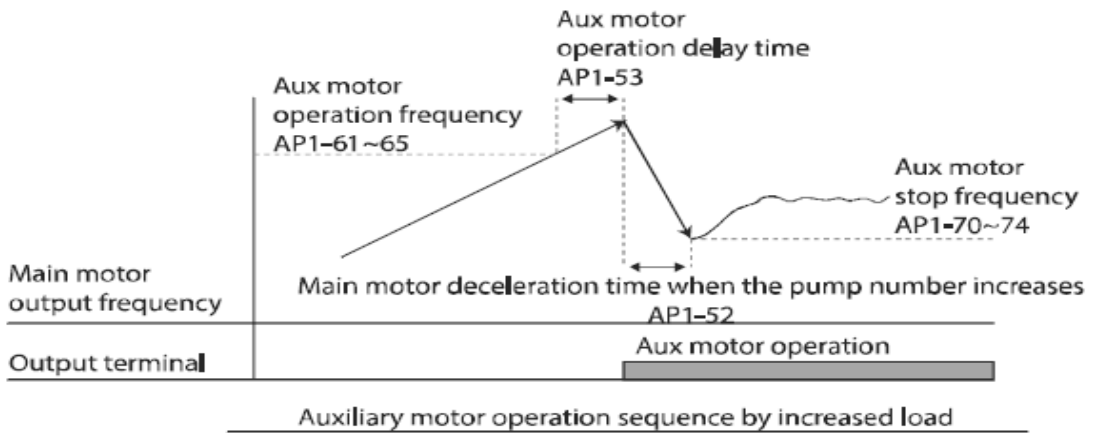

5.44.2 Standby Motor

In case that the number set to MMC in [Relay 1~5] of OUT group is lower than the number of [Num of Aux], auxiliary motor becomes Standby motor state as much as the difference.

Ex) In case that Relay1, 2, 3 and 4, and 5 are set to MMC and the number of [Num of Aux] is 3.

| Relay1 | Relay2 | Relay3 | Relay4 | Relay5 |
|----------|----------|----------|---------|---------|
| Operable | Operable | Operable | Standby | Standby |

In this case, though only Relay1, 2, 3 operate MMC function and the output of Relay is set to MMC, it doesn't work as long as the order is not changed by Interlock and Auto Change.

Standby auxiliary motor becomes operable when there is Interlock or Auto change in Operable auxiliary motor.

5.44.3 Auto Change

The auto change function enables the inverter to automatically switch operations between main and auxiliary motors. Prolonged continuous operation of a motor deteriorates motor capabilities. The auto change function switches the motors automatically when certain conditions are met to avoid biased use of certain motors and protect them from deterioration.

| Group | Code | Name | LCD Display | Parameter Setting | Setting Range | Unit | | |
|-------|----------------------------|----------------------------|-----------------------------|----------------------------------|--------------------|------|---------------|---|
| AP1 | 55 | Auto change mode selection | Auto Ch Mode | 0 | None | 0 | None | |
| | | | | 1 | Aux motor | 1 | AUX Exchange | - |
| | | | | 2 | Main motor | 2 | Main Exchange | - |
| | 56 | Auto change time | Auto Ch Mode | Time value within the range | 00: 00–99: 00 | Sec. | | |
| | 57 | Auto change frequency | Auto Ch Level | Frequency value within the range | Low Freq–High Freq | Hz | | |
| 58 | Auto change operation time | Auto Op Time | Time value within the range | - | Sec. | | | |

Auto Change Setting Details

| Code | Description | | | | | | | | |
|---|---|-------------|-------------|---|------|---|--------------|---|---------------|
| AP1-55 Auto Ch Mode | Select the motors to apply the auto change function. | | | | | | | | |
| | <table border="1"> <thead> <tr> <th>Setting</th> <th>Description</th> </tr> </thead> <tbody> <tr> <td>0</td> <td>None</td> </tr> <tr> <td>1</td> <td>Aux Exchange</td> </tr> <tr> <td>2</td> <td>Main Exchange</td> </tr> </tbody> </table> | Setting | Description | 0 | None | 1 | Aux Exchange | 2 | Main Exchange |
| | Setting | Description | | | | | | | |
| | 0 | None | | | | | | | |
| 1 | Aux Exchange | | | | | | | | |
| 2 | Main Exchange | | | | | | | | |
| Refer to Examples of Auto Change Sequences below for details. | | | | | | | | | |
| AP1-56 Auto Ch Time | Sets the auto change intervals. | | | | | | | | |
| AP1-57 Auto Ch Level | The parameter is for Main Exchange. In case that [AP1-55 Auto Ch Mode] is set to Main Exchange, all the conditions for Auto Change are met under the frequency in which output frequency of Main motors are set in AP1-57. AP1-57 is the frequency to activate Auto Change. | | | | | | | | |

| Code | Description |
|---------------------|--|
| AP1-58 Auto Op Time | Indicates time to activate Auto Change. In case that other conditions for Auto Change are not met in spite of meeting the condition of AP1-56, the value of time in AP1-58 might be bigger than the value set at Auto Ch Time of AP1-56 because of the failure of Auto Change. |

When AP1-55 (Auto Ch Mode) is set to '0 (None),' the auxiliary motors operates based on the order (sequence) set at AP1-43 (Starting Aux). Auto Change functionality is disabled.

When AP1-55 (Auto Ch Mode) is set to '1 (Aux Exchange)', the auxiliary motors operate based on the order (sequence) set at AP1-43 (Starting Aux). Auto Change is activated when auxiliary motors are in the operating state over time of AP1-56 and then every auxiliary motor is stopped.

NOTE

Auto change does not work while the auxiliary motors are operating. Auto change is operated only when all the auxiliary motors are stopped and if all the conditions set for the auto change are met. When the inverter stops, all motors stop operating, and the auxiliary motor with the highest priority becomes the starting auxiliary motor. If the inverter power is turned off then turned back on, the auxiliary motor set at AP1-43 (Starting Aux) becomes the starting auxiliary motor.

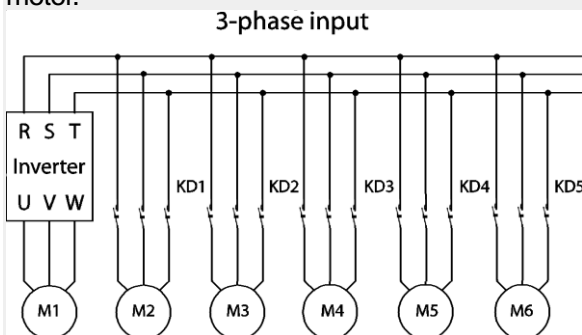

Start order and stop order of the auxiliary motors are based on the order set at AP1-49 (FIFO/FILO).

The following diagrams depict the auxiliary motor start and stop sequence, based on a FIFO configuration, when the inverter operation time exceeds the auto change interval set at AP1-58. If all the auxiliary motors are turned off and the inverter operation frequency is below the frequency set at AP1-58 (Auto Op Time), auto change is operated. Then, when the inverter frequency increases due to decrease in the feedback, auxiliary motor #2 starts instead of auxiliary motor #1 due to this auto change (auxiliary motor #1 starts last, for it has the lowest priority).

Later on during the operation, when the feedback increases and the auxiliary motors begin to stop, the FILO setting is applied to control the order for the auxiliary motors to stop.

Once the auto change is operated, the auxiliary motor that started first is given the lowest priority and all the other auxiliary motors' priority level increases by 1. Then, general MMC operation continues.

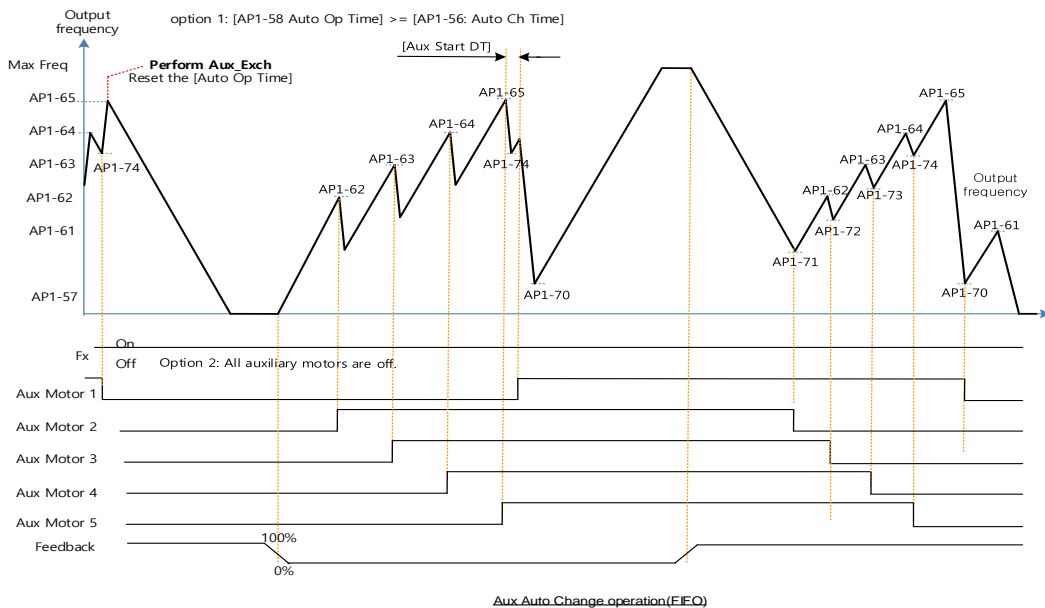
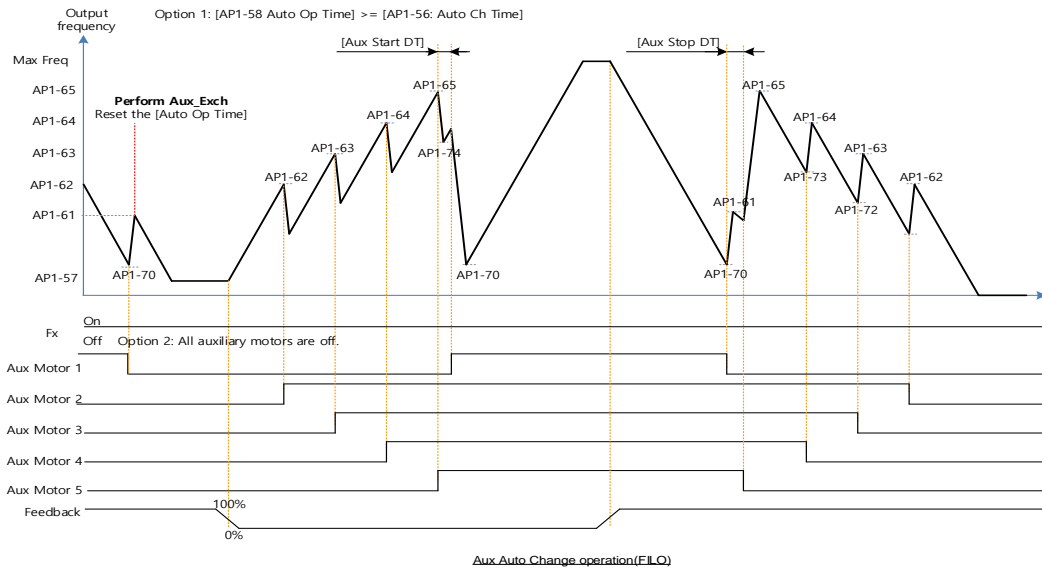

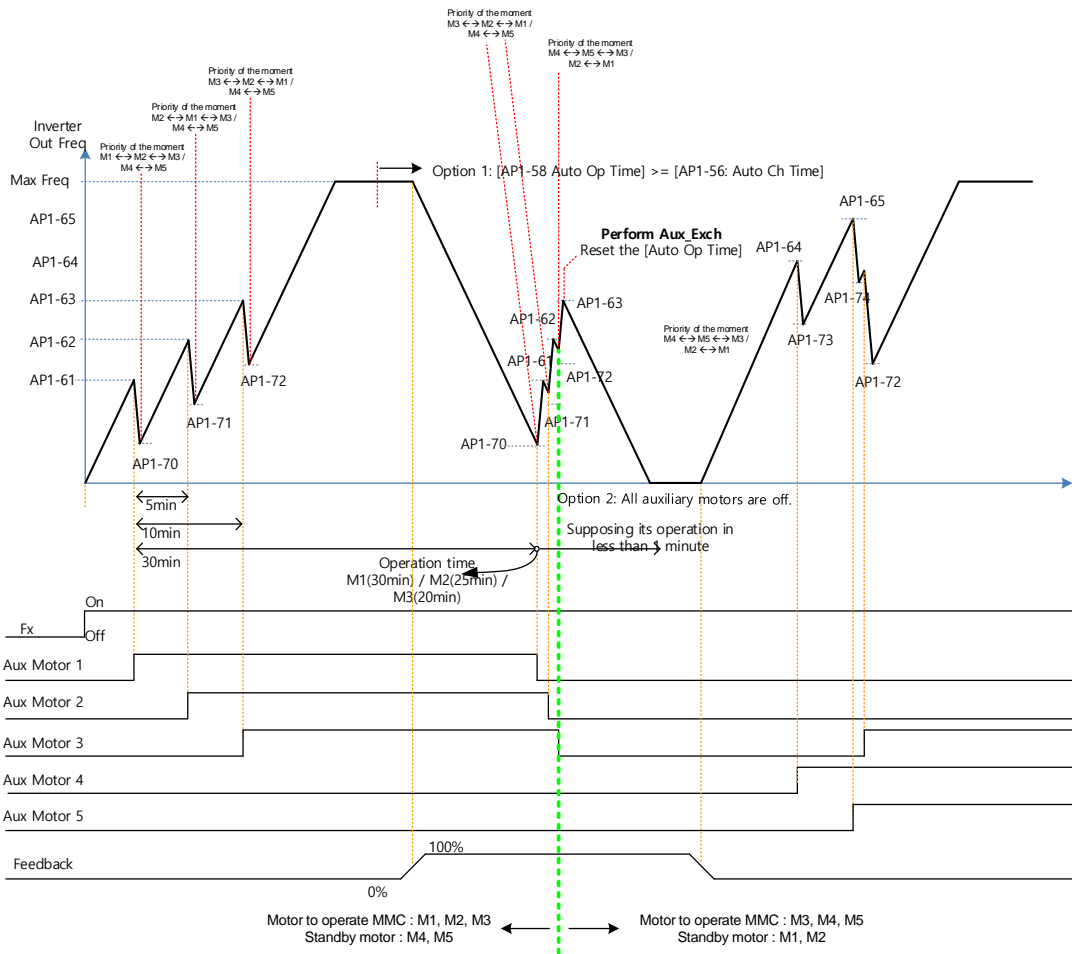

Aux Auto Change operation (Op Time Order) when operable motor and standby motor are set to 3 and 2 each

When AP1-55 (Auto Ch Mode) is set to '2 (Main Exchange),' the system uses all the motors (main and auxiliary motors) regardless of the types. The auxiliary motor with the highest priority is operated first and used as the main motor. Then, when the auto change conditions are met, this motor is stopped and the motor priorities are re-arranged. This way, the system always operates the motor with the highest priority and uses it as the main motor of the MMC operation. In this case, before auto change is operated for the main motor, the interlock delay time set at AP1-91 (Interlock DT) is applied.

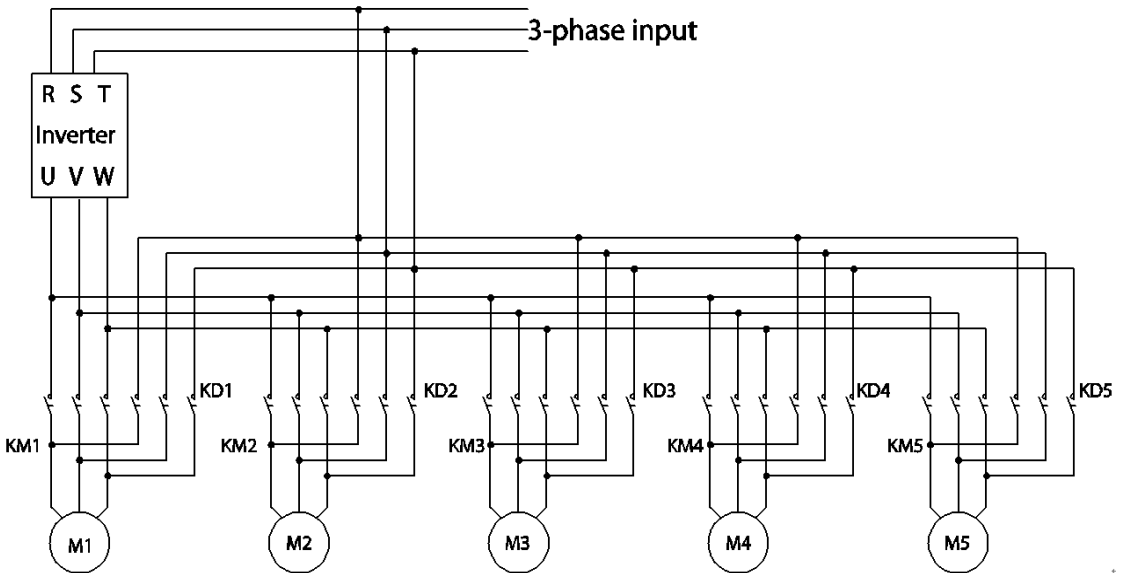
**NOTE**

Auto change does not work while the auxiliary motors are operating. Auto change is operated only when all the auxiliary motors are stopped and if all the conditions set for the auto change are met. When the inverter stops, all motors stop operating, and the auxiliary motor with the highest priority becomes the starting auxiliary motor. If the inverter power is turned off then turned back on, the auxiliary motor set at AP1-43 (Starting Aux) becomes the starting auxiliary motor.

The following diagrams depict the auto change operation when AP1-55 (Auto Ch Mode) is set to '2 (Main),' when the inverter operation time exceeds the auto change interval set at AP1-58. If the inverter operation frequency is below the frequency set at AP1-57, all the auxiliary motors including the start auxiliary motor are turned off. After the delay time set at AP1-91 (Interlock DT) elapses, the 'Main' auto change is operated. After the 'Main' auto change, the auxiliary motor that was turned on after the starting auxiliary motor becomes the main motor.

In the following diagrams, because auxiliary motor #1 is the starting auxiliary motor. Auxiliary motor #2 becomes the main motor after the auto change. The auxiliary motor on/off operation is identical to that of Aux Exchange, and the 'off' conditions differ based on the FIFO/FILO configuration.

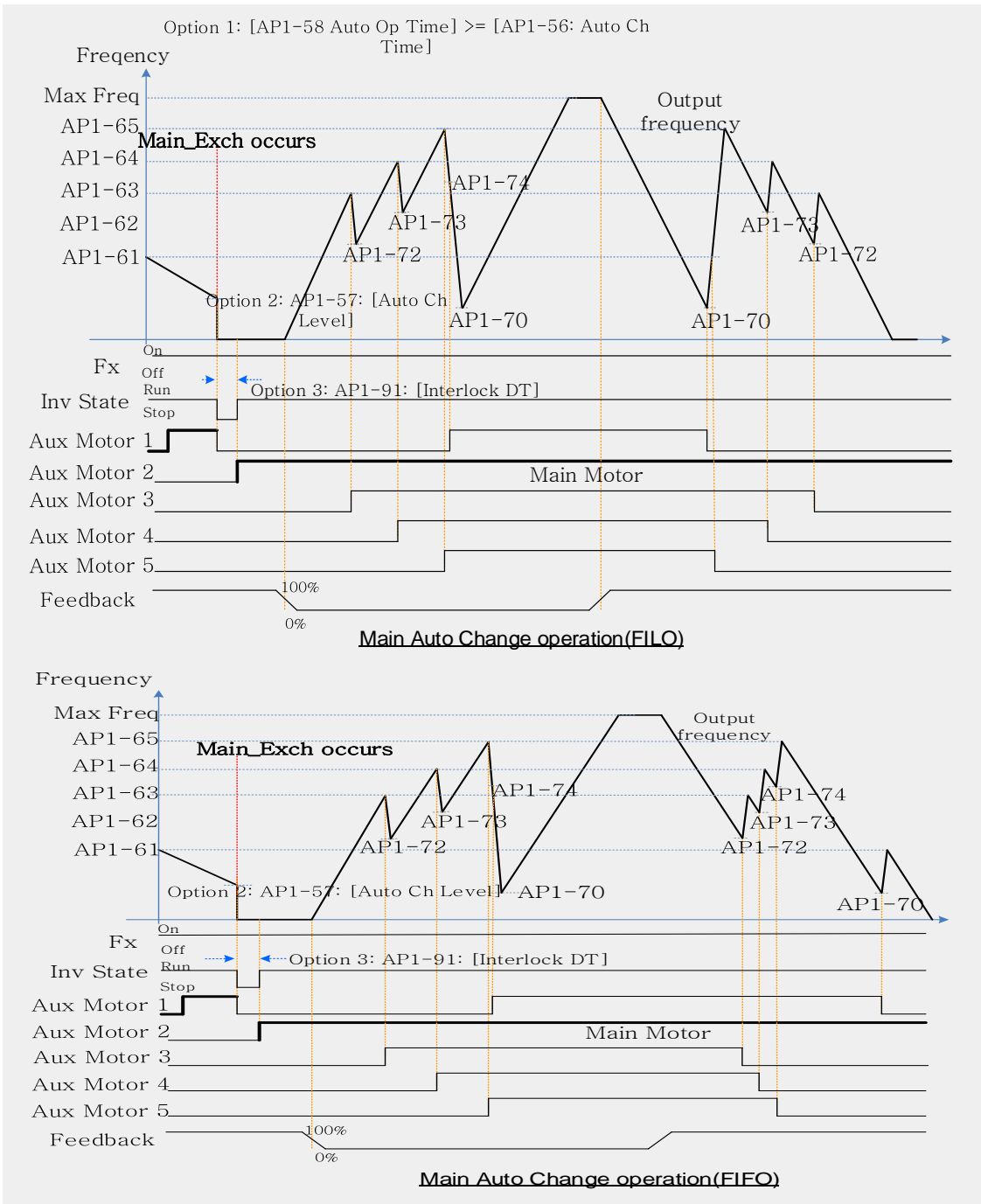

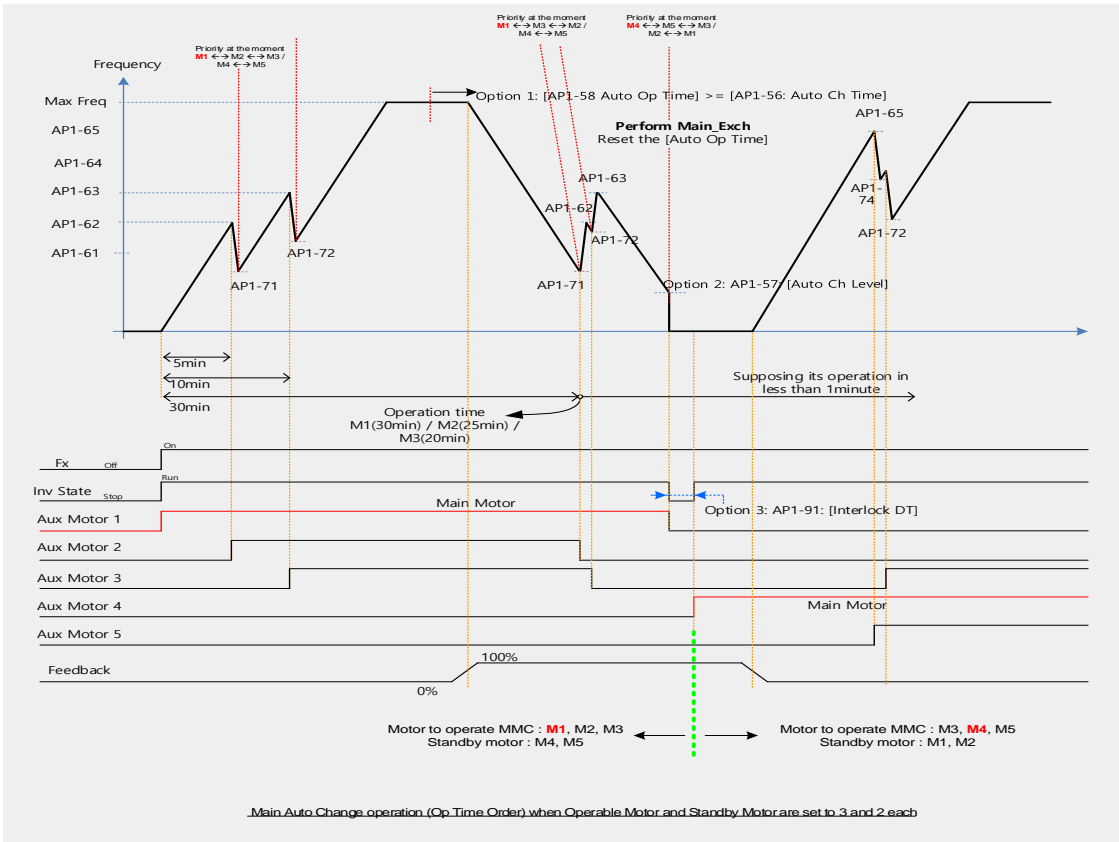

5.44.4 Interlock

When there is motor trouble, the interlock feature is used to stop the affected motor and replace it with another that is not currently operating (off state). To activate the interlock feature, connect the cables for abnormal motor signal to the inverter input terminal and configure the terminals as interlock 1–5 inputs. Then, the inverter decides the motor’s availability based on the signal inputs. The order in which the alternative motor is selected is decided based on the auto change mode selection options set at AP1-55.

| Group | Code | Name | LCD Display | Parameter Setting | Setting Range | | Unit |
|-------|------|---------------------|-------------|-------------------|---------------|-----|------|
| AP1 | 90 | Interlock selection | Interlock | 1 | 0 | NO | - |
| | | | | | 1 | YES | |

After configuring the IN-65–71 multi-purpose input terminals as Interlock input 1–5, if an interlock signal is received from an auxiliary motor, the output contacts are turned off for the motor and the motor is excluded from the MMC operation. This causes the priority level of the auxiliary motors with lower priority level than the interlocked motor to be increased by 1.

The interlock is released when the input terminals (IN-65–71) are turned off, and the relevant auxiliary motor is included in the MMC operation again, with lowest priority.

When the inverter stops, all motors stop operating, and the auxiliary motor with the highest priority becomes the starting auxiliary motor.

When the multi-purpose input terminals (IN-65–71, P1–7 Define) are set for the interlock feature, an interlock is 'Off' when the contacts are valid, and 'On' when they are invalid.

InterLock Setting Details

| Code | Description |
|---------------------|--|
| AP1-90 InterLock | Enables or disables the Interlock. |
| AP1-91 Interlock DT | Sets the delay time before the Interlock occurs. |

Note

IN-65–71 PxDefine: Select the terminal from the input terminal function group (IN-65–71) and set Interlock 1-5 respectively with the correct motor order. When auto change mode selection (AP1–55) is set to '0 (None)' or '1 (Aux)', and if 5 motors are operated, including the main motor, the interlock numbers 1,2,3,4,5 refer to the motors connected to Relay 1,2,3,4,5 (If interlock numbers 1,2,3,4,5 are connected to Relay 1,2,3,4,5 at the inverter output terminal). However, if auto change mode selection (AP1-55) is set to '2 (Main)', and the main and auxiliary motors are connected to the inverter output terminal Relay 1,2,3,4, Interlock 1,2,3,4 are the monitors connected to Relay 1,2,3,4.

The figure below shows the motor operating as a sequence by FILO. The motor turns on from the starting auxiliary motor (Starting Aux) by order, and turns off depending on the rise of PID feedback. At this point, the interlock occurs at auxiliary motor #2 by multi-function input, the auxiliary motor turns off. The output frequency falls to the frequency set at AP1-71, and rises again. Then, the interlock occurs at auxiliary motor #1. The auxiliary motor stops and falls to the frequency set at AP1-71, and then rises again. Interlock #2 should be released first, then release interlock #1 to let the auxiliary motor operate (When interlocks are released, they will have the lowest priority of the operating motors). If the auxiliary motor turns off by a rise of Feedback, the auxiliary motors turns off in order from 1 to 5, because auxiliary motor #1 turned on last. The interlocked auxiliary motor will have the lowest priority.

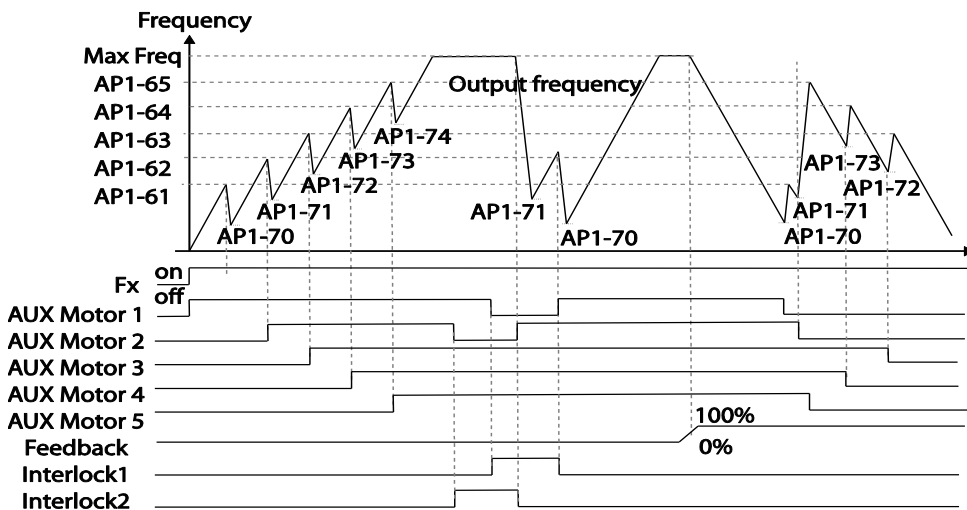

Interlock operation(FILO)

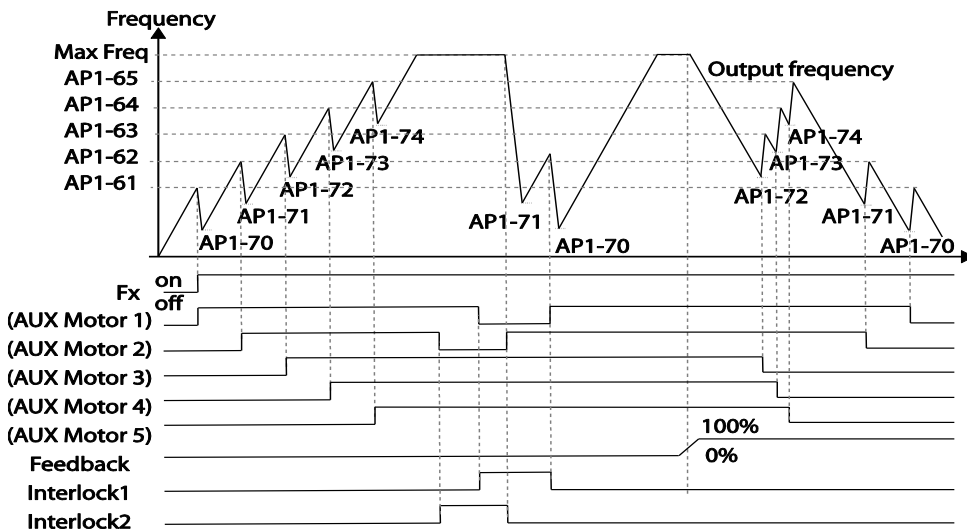

Interlock operation(FILO)

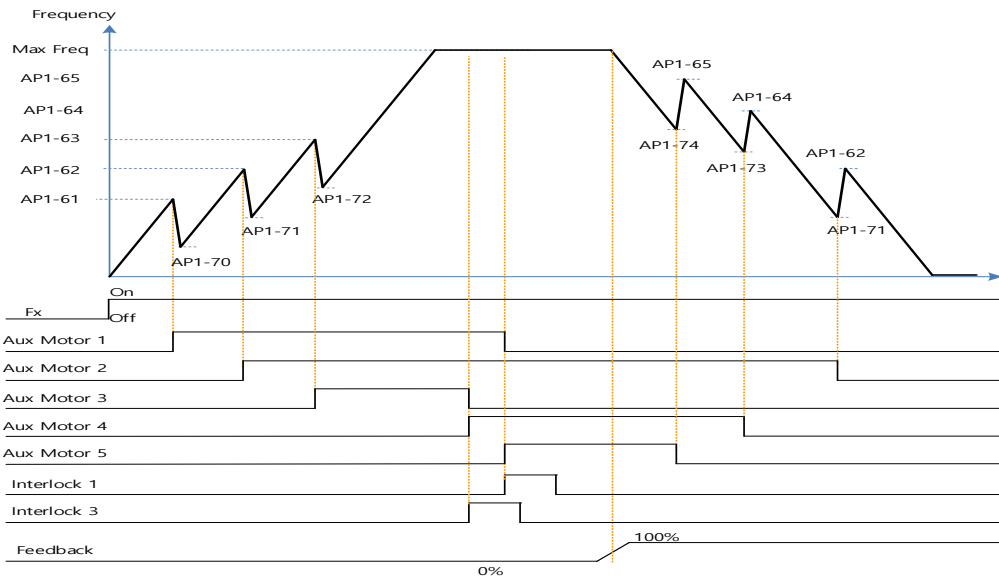

Interlock operation (Op. time Order) when Operable Motor and Standby Motor are set to 3 and 2 each

When interlock is released, the auxiliary motor's priority becomes different. When Interlock occurs at auxiliary motor #3, the priority is number 1>3>4>5>2. When it occurs at auxiliary motor #1, the priority is number 3>4>5>2>1. The figure below shows the order of the auxiliary motors activating depending on the priority (of Interlock occurring and releasing). In the figure, the order is the same for FILO/FIFO, because the auxiliary motor turns on.

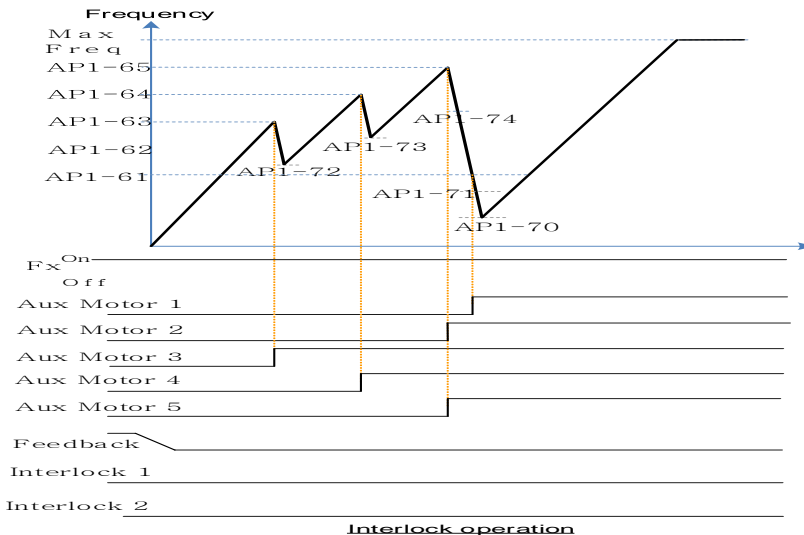

Interlock operation

In case that Operable Motor and Standby Motor are set to 3 and 2 each, it operates in the order of "Aux Motor 2 ↔ Aux Motor 4 ↔ Aux Motor 5".

5.44.5 Aux Motor Time Change

It is used to set a motor to the smallest number among Drives not inter-locked by [AP1-43 Starting Aux] and place others in order based on it when operating time of every motor is deleted through <1:All> of [AP1-98 AuxRunTime Clr].

In case that operating time of each motor is deleted through <2: Aux1> ~ <6: Aux5> of [AP1-98 AuxRunTime Clr] or changed by combining [AP1-96 AuxRunTime Day] and [AP1-97 AuxRunTime Min], motor stopped changes the priority with motor stopped as operating motor does with operating motor.

The table below shows the case to change the operating time of Aux Motor2 running on the same condition of Sequence1.

| Sequences | Aux Priority 1 (Operating time: min) | Aux Priority 2 (Operating time: min) | Aux Priority 3 (Operating time: min) | Aux Priority 4 (Operating time: min) | Aux Priority 5 (Operating time: min) |
|---|---|---|---|---|---|
| 1 | Aux Motor3 (00:30) <Operating> | Aux Motor2 (00:40) <Operating> | Aux Motor1 (00:50) <Operating> | Aux Motor4 (01:30) <Operating> | Aux Motor 5 (01:50) <Operating> |
| Set <3 Aux2of [AP1-98 AuxRunTime Clr] | | | | | |
| 2 | Aux Motor2 (00:00) <Operating> | Aux Motor3 (00:30) <Operating> | Aux Motor1 (00:50) <Operating> | Aux Motor4 (01:30) <Operating> | Aux Motor 5 (01:50) <Operating> |
| Set time of Aux2to 2:00 through [AP1-97 AuxRunTime Min] | | | | | |
| 3 | Aux Motor3 (00:30) <Operating> | Aux Motor1 (00:50) <Operating> | Aux Motor2 (02:00) <Operating> | Aux Motor4 (01:30) <Stopping> | Aux Motor 5 (01:50) < Stopping > |

The table below shows the case to change the operating time of Aux Motor5 stopped on the same condition of Sequence1

| Sequences | Aux Priority 1 (Operating time: min) | Aux Priority 2 (Operating time: min) | Aux Priority 3 (Operating time: min) | Aux Priority 4 (Operating time: min) | Aux Priority 5 (Operating time: min) |
|--|---|---|---|---|---|
| 1 | Aux Motor3 (00:30) <Operating> | Aux Motor2 (00:40) <Operating> | Aux Motor1 (00:50) <Operating> | Aux Motor4 (01:30) <Stopping> | Aux Motor 5 (01:50) <Stopping> |
| Set <6: Aux5> of [AP1-98 AuxRunTime Clr] | | | | | |
| 2 | Aux Motor3 (00:30) <Operating> | Aux Motor2 (00:40) <Operating> | Aux Motor1 (00:50) <Operating> | Aux Motor 5 (0) <Stopping> | Aux Motor 4 (01:30) <Stopping> |
| Set time of Aux5 to 2:00 through [AP1-97 AuxRunTime Min] | | | | | |
| 3 | Aux Motor3 (00:30) <Operating> | Aux Motor2 (00:40) <Operating> | Aux Motor1 (00:50) <Operating> | Aux Motor4 (01:30) <Stopping> | Aux Motor 5 (02:00) <Stopping> |

5.44.6 Regular Bypass

This function controls the motor speed based on the feedback amount instead of using the PID. Auxiliary motors may be controlled with this feature based on the feedback amount.

| Group | Code | Name | LCD Display | Parameter Setting | | Setting Range | Unit |
|-------|-------|--------------------------------------|----------------|----------------------------------|--------------------------------|---------------|------|
| AP1 | 41 | Bypass selection | Regul Bypass | 1 | 0 | No | - |
| | | | | | 1 | Yes | |
| | 61–65 | #1–5 auxiliary motor start frequency | Start Freq 1–5 | Frequency value within the range | Freq Low Limit–Freq High limit | Hz | |
| | 70–74 | #1–5 auxiliary motor stop frequency | Stop Freq 1–5 | Frequency value within the range | Low Freq–High Freq | Hz | |
| OUT | 31–35 | Multi-function relay1–5 | Relay 1–5 | 21 | Multiple motor control(MMC) | - | - |
| | 36 | Multi-function 1 item | Q1 Define | 40 | KEB Operation | - | - |

Regular Bypass Detail Settings

| Code | Description |
|---|---|
| AP1-41 Regular Bypass | Sets the regular bypass mode. |
| | Mode Setting |
| | 0 No |
| | 1 Yes |
| AP1-61–65 Start Freq 1–5 | Sets the auxiliary motor start frequency. |
| AP1-70–74 Stop Freq 1–5 | Sets the auxiliary motor stop frequency. |
| OUT-31–35 Relay 1–5 OUT-36 Q1 Define | Set OUT31–35 to '21 (MMC)' to use the out terminal for auxiliary motor operation. The number of configured output terminals determines the total number of auxiliary motors to be used. |

When an input set by the PID feedback of the analog input terminal (I or V1 or Pulse) is 100%, divide the area by the number of motors being used (including the main motor). Each auxiliary motor turns on when feedback reaches the relevant level and turns off when feedback goes below the relevant level. The primary motor increases its speed based on the feedback and when it reaches the start frequency of the relevant auxiliary motor and decelerates to the stop frequency.

The primary motor reaccelerates when the frequency increases, depending on the

feedback increase. If the relevant auxiliary motor is turned off because of the feedback decrease, the primary motor accelerates from the stop frequency to the start frequency.

To use the regular bypass function, '1 (Yes)' has to be selected in the MMC and PID functions. Only FILO operates between the AP1-49 (FIFO/FILO) in a regular bypass function.

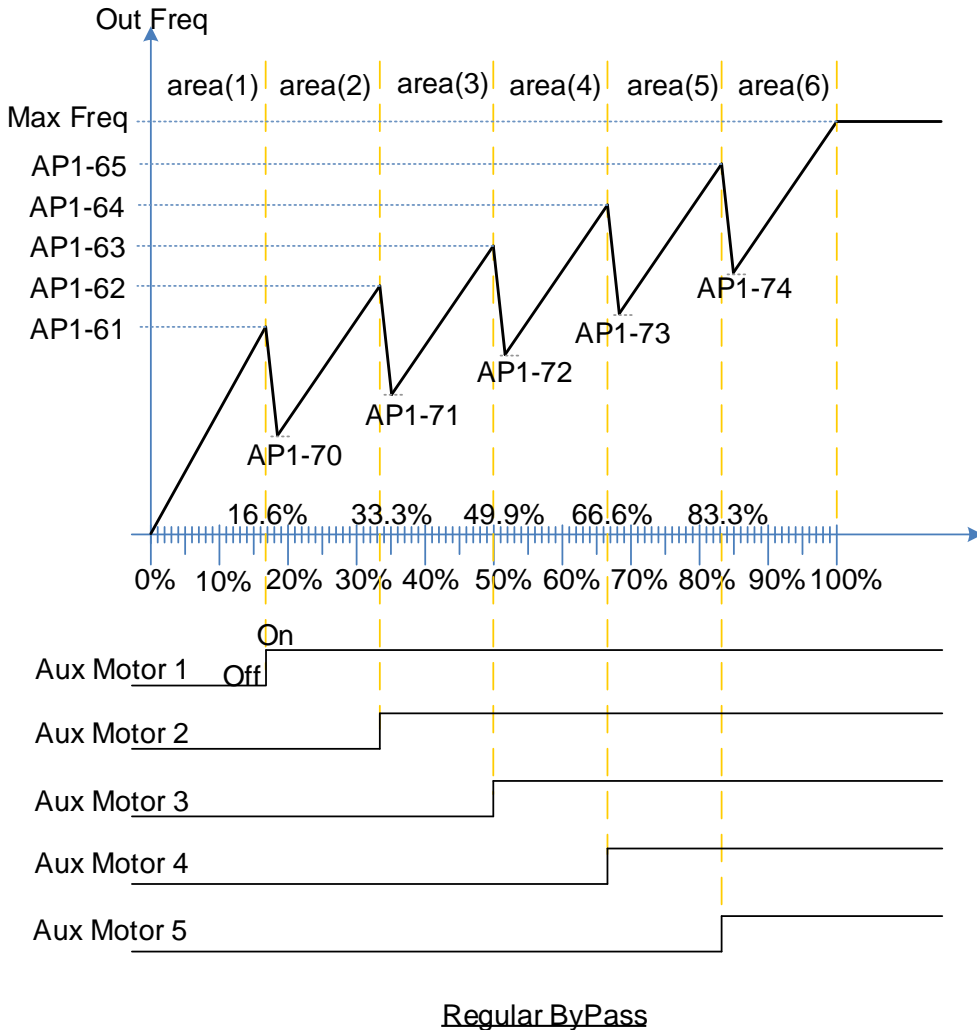

5.44.7 Aux Motor PID Compensation

When the number of operating auxiliary motors increases, the flow rate of the pipe also

increases and the pressure of the pipe line decreases. Aux motor PID compensation compensates for this pressure when the number of the auxiliary motor increases. By adding the additional PID reference value (relevant to the auxiliary motor) to the current reference, the loss of pressure can be compensated for.

Auxiliary PID Compensation Detailed Settings

| Code | Description |
|----------------------------------|---|
| AP1-80-84 Aux 1-5 Ref Comp | Set the relevant PID reference compensation rate whenever the auxiliary motor is turned on. The PID reference can be set over 100%, but when it exceeds 100%, the maximum value of the PID reference is limited to 100%. Unit band value is the value between unit 100%-0%. |

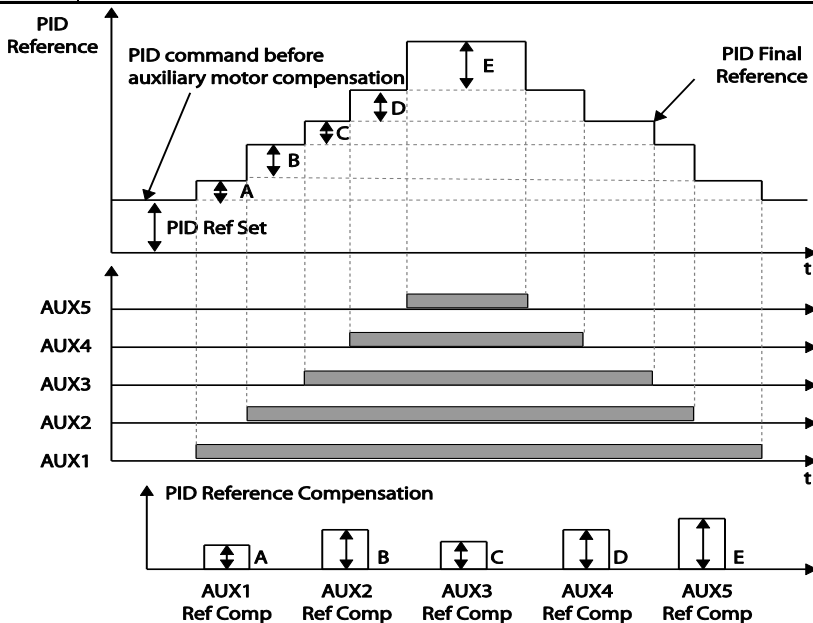

< Auxiliary motor PID compensation >

NOTE

When the aux reference value is set to 100%, the final PID reference becomes 100%. In this case, output frequency of the inverter does not decelerate because the PID output does not decelerate even if the input feedback value is 100%.

5.44.8 Master Follower

It is used to control multiple inverters with an inverter. When [AP1-40 MMC Sel] is set to <2 : Multi Follower> or <3 : Multi Master>, it is called as {Leader Drive}. The rest inverters set to <4 : Serve Drv> are called as {Serve Drive}.

Leader Drive

It is an inverter to execute PID control with PID Feedback from sensor, control Multi Motor and function as Master of communication.

In addition, if it is set to Leader Drive, Drive turned on at first performs functions of Soft Fill(Pre-PID), Sleep/WakeUp and Aux Motor PID Compensation).

Serve Drive

It is an inverter to operate motors with Leader Drive.

Each inverter and motor has the same number(ID), [COM-01 Int485 St ID].

Among the operating motors, the motor with the lowest priority is called Main Motor and the rest of motors are called as Aux Motor.

※In case that every motor is stopped, the motor with the highest priority is called as Main Motor. This is, Main Motor and Aux Motor are changed according to the situation and Leader Drive and Serve Drive are fixed.

The picture below represents foundational composition.

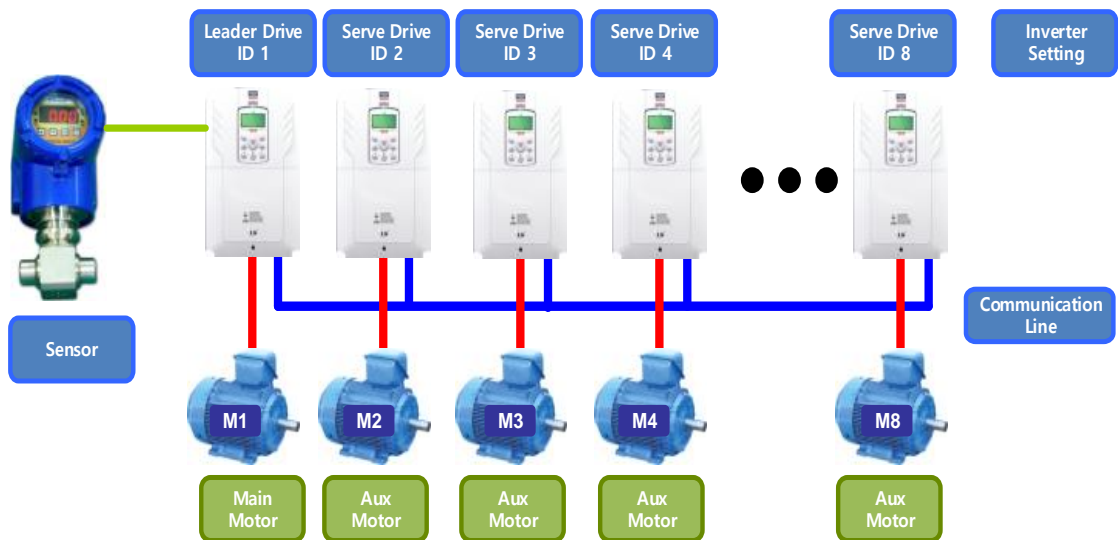

5.44.8.1 Multi Mater Mode

Only Main Motor can be controlled by PID and Aux Motor performs the operating mode with Follower Freq.

The picture below shows that the priority is “Motor1 (M1) ↔ Motor2 (M2) ↔ Motor3 (M3)”.
(The priority can be changed automatically according to operating time)

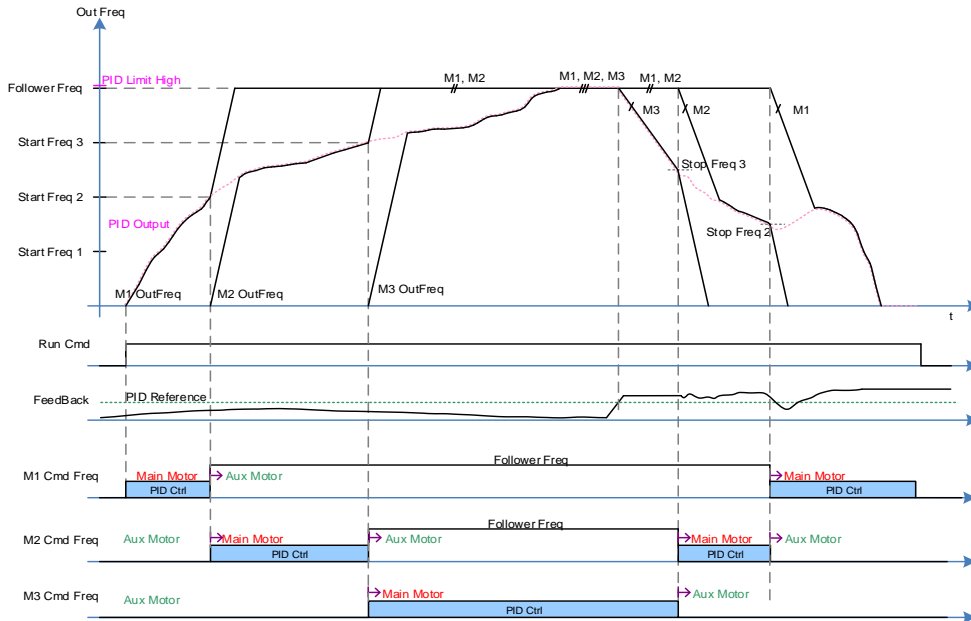

A condition that extra Aux Motor is turned on .

After a real operating frequency reaches the frequency set in Start Freq belonging to the next priority number and the time set in AP1-53(Aux Start DT) passes, AP1-44(Aux Motor Run) increases (+1) and it becomes Aux Motor, accelerating based on time of [DRV-03 Acc Time]/[DRV-04 Dec Time] until [AP1-60 Follower Freq].

At the same time, as an inverter corresponding to the next priority is turned on, the motor becomes Main Motor(available PID control). It is possible to check the priority in [AP1-45/46 Aux Priority].

A condition that Aux Motor is turned off.

If the real operating frequency of Main Motor is lower than the frequency set in Stop Freq, AP1-44(Aux Motor Run) decreases(-1) after the time set in AP1-54(Aux Stop DT) and the present Main Motor becomes Aux Motor, decelerating based on time of [DRV-04 Dec Time] until 0Hz.

At the same time, the motor corresponding to the previous priority becomes Main Motor(available PID control). It is possible to check the priority in [AP1-45/46 Aux Priority].

5.44.8.2 Multi Follower Mode

It is a mode to control motors turned on with the same PID output frequency. The picture below shows that the priority is “Motor1 (M1) ↔ Motor2 (M2) ↔ Motor3 (M3)”. (The priority can be changed automatically according to operating time).

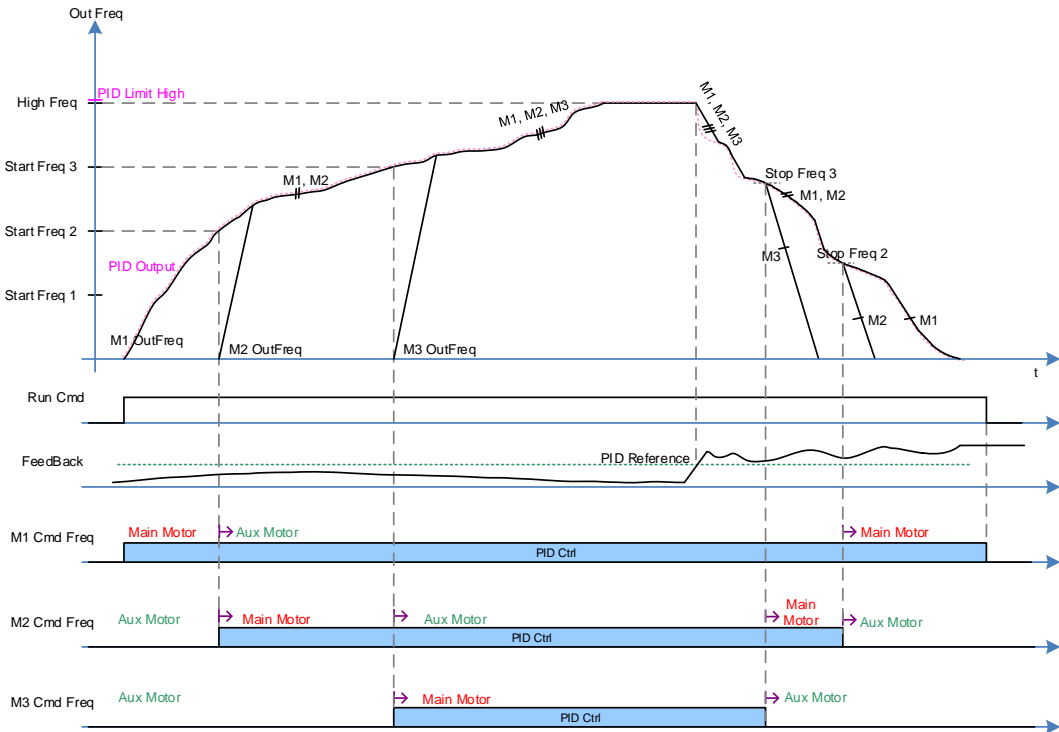

A condition that extra Aux Motor is turned on .

After a real operating frequency reaches the frequency set in Start Freq belonging to the next priority number and the time set in AP1-53(Aux Start DT) passes, AP1-44(Aux Motor Run) increases (+1). In addition, Aux Motor with the next priority of Main Motor is turned on and the new operating Aux Motor becomes Main Motor. Operating motors can be controlled together by PID. It is possible to check the priority in [AP1-45/46 Aux Priority].

A condition that Aux Motor is turned off.

If the real operating frequency of Main Motor is lower than the frequency set in Stop Freq, AP1-44(Aux Motor Run) decreases(-1) after the time set in AP1-54(Aux Stop DT) and the present Main Motor becomes Aux Motor, decelerating based on time of [DRV-04 Dec Time] until 0Hz.

At the same time, the rest of operating motors last PID control. It is possible to check the priority in [AP1-45/46 Aux Priority].

5.44.8.3 Re-arrangement of priority based on operating time.

The priority of each Motor is arranged automatically based on operating time. Among operating Motors, Motor with the longest operating time is placed at the last. The moment for the priority arrangement is the time when the number of motor is changed.

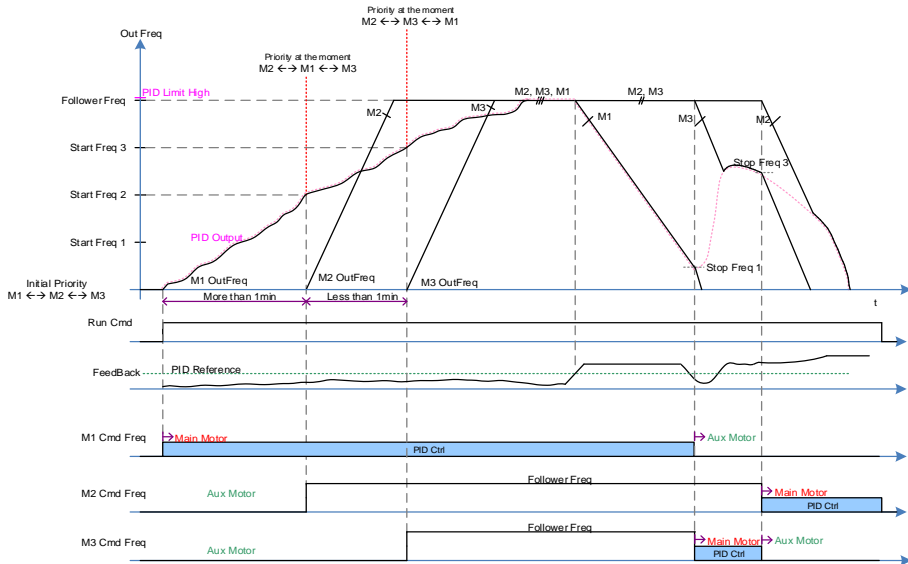

The picture below shows the operating time of M1 is the longest during Multi Follower Mode.

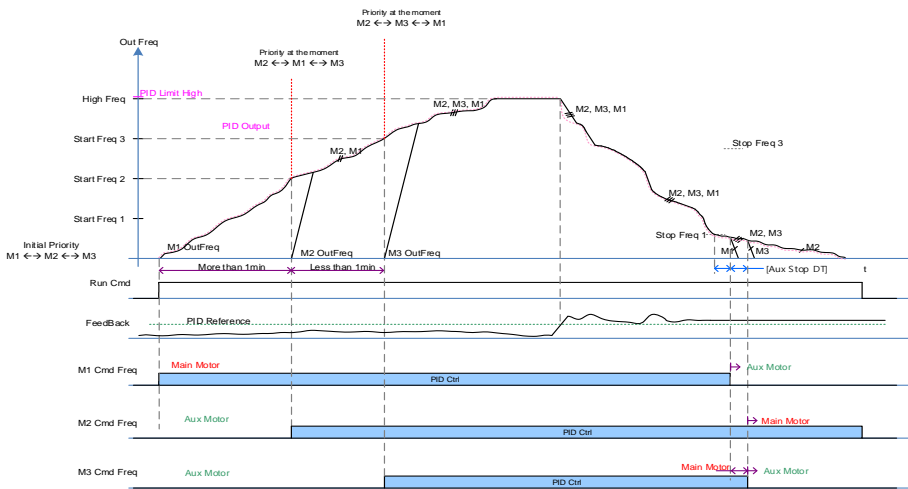

The conditions that Aux Motor is turned on and off are same as the description of Multi Master Mode and Multi Follower Mode.

5.44.8.4 Master Follower Interlock

As Interlock signals are sent from Serve Drive, Leader Drive puts together through Communication Line. Every Trip such as HAND State or OFF State of Serve Drive is processed by Interlock in Leader Drive .

This is, other Server Drives keep performing Master Follower function except the cases that it is in HAND/OFF State or there are trips

If Leader Drive is HAND State or OFF state, Master Follower system is not activated.

In case that Pipe Broken and Interlock Trip are caused in Leader Drive, every drive operating is stopped and Master Follower keeps performing the function except Leader Drive if there is another Trip.

(Leader Drive executes PID control and overall system control consistently.)

In this operating priority (M1 ↔ M2 ↔ M3 ↔ M4 ↔ M5 ↔ M6 ↔ M7 ↔ M8), if interlock3 or any trip and HAND/OFF State are caused, the motor is activated in this order(M1 ↔ M2 ↔ M4 ↔ M5 ↔ M6 ↔ M7 ↔ M8).

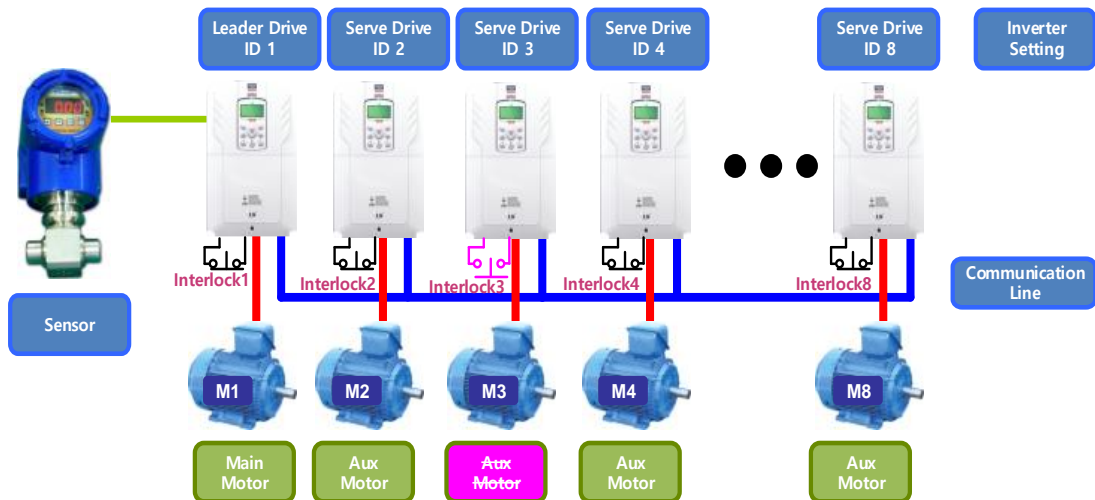

The picture below shows the function in case that M3 becomes HAND/OFF State or interlock and Trip are caused.(supposing that the priority is not changed),(interlock is the function corresponding to B terminal(Normal close)).

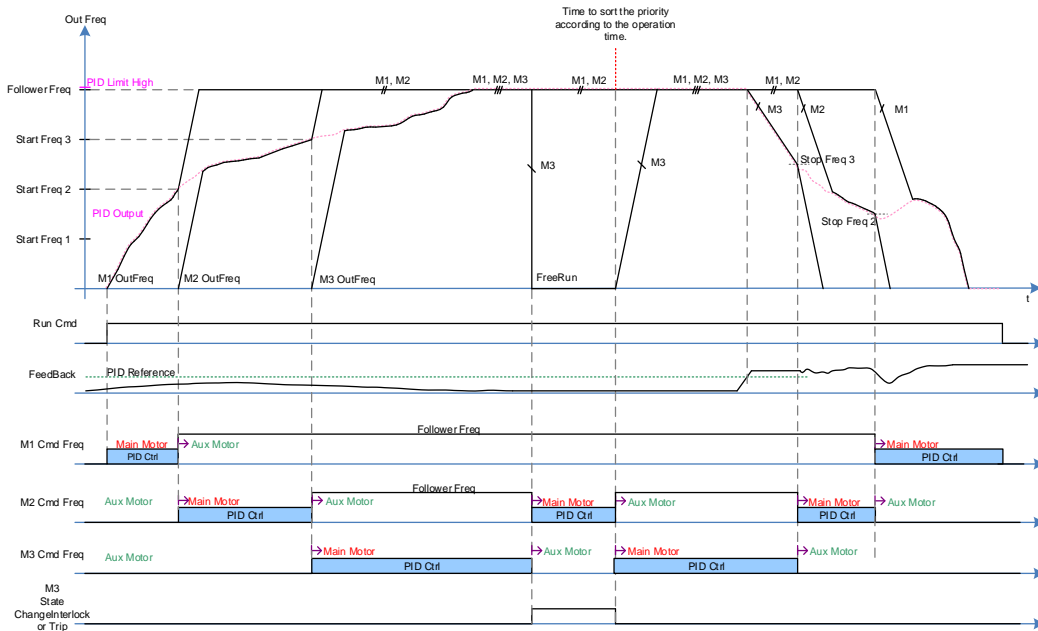

5.45 Multi-function Output On/Off Control

Set reference values (on/off level) for analog input and control output relay or multi-function output terminal on/off status accordingly.

| Group | Code | Name | LCD Display | Parameter Setting | | Setting Range | Unit |
|-------|------|-------------------------------------|-----------------|-------------------|--------|-----------------------------------|------|
| ADV | 66 | Output terminal on/off control mode | On/Off Ctrl Src | 1 | V1 | 0-8 | - |
| | 67 | Output terminal on level | On-C Level | 90.00 | | Output terminal off level-100.00% | % |
| | 68 | Output terminal off level | Off-C Level | 10.00 | | 0.00-Output terminal on level | % |
| OUT | 31 | Multi-function relay 1 item | Relay 1 | 26 | On/Off | - | - |
| | 33 | Multi-function output 1 item | Q1 Define | | | | |

Multi-function Output On/Off Control Setting Details

| Code | Description |
|---|--|
| ADV-66 OnOff Ctrl Src | Select analog input On/Off control. |
| ADV-67 On Ctrl Level , ADV-68 Off Ctrl Level | Set On/Off level at the output terminal. |

Analog input

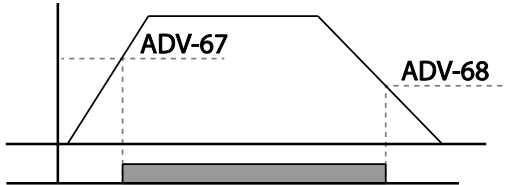

Multi-function Output On/Off Control(26)

5.46 Press Regeneration Prevention

Press regeneration prevention is used during press operations to prevent braking during the regeneration process. If motor regeneration occurs during a press operation, motor operation speed automatically goes up to avoid the regeneration zone.

| Group | Code | Name | LCD Display | Parameter Setting | | Setting Range | Unit |
|-------|--------------------------------------|--|----------------|-------------------|-------------|---------------------------|------|
| ADV | 74 | Select press regeneration prevention for press | RegenAvd Sel | 0 | No | 0-1 | - |
| | 75 | Press regeneration prevention operation voltage level | RegenAvd Level | 350 V | | 200 V class: 300-400 V | V |
| | | | | 700 V | | 400 V class: 600-800 V | |
| | 76 | Press regeneration prevention compensation frequency limit | CompFreq Limit | 1.00 (Hz) | | 0.00-10.00 Hz | Hz |
| | 77 | Press regeneration prevention P-Gain | RegenAvd Pgain | 50.0 (%) | | 0.0-100.0% | % |
| 78 | Press regeneration prevention I gain | RegenAvd I gain | 500 (ms) | | 20-30000 ms | ms | |

Press Regeneration Prevention Setting Details

| Code | Description |
|--|--|
| ADV-74 RegenAvd Sel | Frequent regeneration voltage from a press load during a constant speed motor operation may force excessive stress on the brake unit, which may damage or shorten brake life. To prevent this, select ADV-74 (RegenAvd Sel) to control DC link voltage and disable the brake unit operation. |
| ADV-75 RegenAvd Level | Set brake operation prevention level voltage when the DC link voltage goes up due to regeneration. |
| ADV-76 CompFreq Limit | Set an alternative frequency width that can replace actual operation frequency during regeneration prevention. |
| ADV-77 RegenAvd Pgain ADV-78 RegenAvd Igain | To prevent regeneration zone, set P-Gain/I gain in the DC link voltage suppress PI controller. |

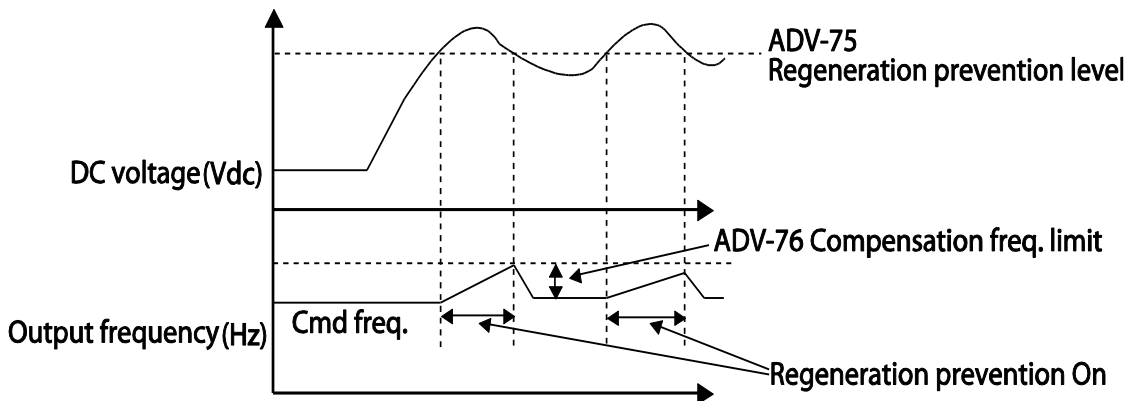

Note

Press regeneration prevention does not operate during accelerations or decelerations; it only operates during constant speed motor operation. When regeneration prevention is activated, output frequency may change within the range set at ADV-76 (CompFreq Limit).

5.47 Analog Output

An analog output terminal provides an output of 0–10 V voltage, 4–20 mA current, or 0–32 kHz pulse.

5.47.1 Voltage and Current Analog Output

An output size can be adjusted by selecting an output option at the AO (Analog Output) terminal. Set the analog voltage/current output terminal setting switch (SW5) to change the output type (voltage/current).

| Group | Code | Name | LCD Display | Parameter Setting | | Setting Range | Unit |
|-------|------|-------------------------|-------------|-------------------|-----------|----------------|------|
| OUT | 01 | Analog output1 | AO1 Mode | 0 | Frequency | 0–15 | - |
| | 02 | Analog output1 gain | AO1 Gain | 100.0 | | -1000.0–1000.0 | % |
| | 03 | Analog output1 bias | AO1 Bias | 0.0 | | -100.0–100.0 | % |
| | 04 | Analog output1 filter | AO1 Filter | 5 | | 0–10000 | ms |
| | 05 | Analog constant output1 | AO1 Const % | 0.0 | | 0.0–100.0 | % |
| | 06 | Analog output1 monitor | AO1 Monitor | 0.0 | | 0.0–1000.0 | % |

| Code | Description |
|------------|--|
| OUT-01 AO1 | Select a constant value for output. The following example for output voltage |

| Mode | setting. | | |
|-------------------------------------|---|--|---|
| | Setting | Function | |
| | 0 | Frequency | Outputs operation frequency as a standard. 10 V output is made from the frequency set at DRV-20 (Max Freq). |
| | 1 | Output Current | 10 V output is made from 150% of inverter rated current. |
| | 2 | Output Voltage | Sets the outputs based on the inverter output voltage. 10 V output is made from a set voltage in BAS-15 (Rated V). If 0 V is set in BAS-15, 200 V/400 V models output 10 V based on the actual input voltages (240 V and 480 V respectively). |
| | 3 | DC Link Volt | Outputs inverter DC link voltage as a standard. Outputs 10 V when the DC link voltage is 410 V DC for 200 V models, and 820 V DC for 400 V models. |
| | 4 | Output Power | Monitors output wattage. 150% of rated output is the maximum display voltage (10 V). |
| | 7 | Target Freq | Outputs set frequency as a standard. Outputs 10 V at the maximum frequency (DRV-20). |
| | 8 | Ramp Freq | Outputs frequency calculated with Acc/Dec function as a standard. May vary with actual output frequency. Outputs 10 V. |
| | 9 | PID Ref Value | Outputs command value of a PID controller as a standard. Outputs approximately 6.6 V at 100%. |
| | 10 | PID Fdk Value | Outputs feedback volume of a PID controller as a standard. Outputs approximately 6.6 V at 100%. |
| | 11 | PID Output | Outputs output value of a PID controller as a standard. Outputs approximately 10 V at 100%. |
| | 12 | Constant | Outputs OUT-05 (AO1 Const %) value as a standard. |
| | 13 | EPID1 Output | Output is based on the output value of the external PID1 controller. Outputs 10 V in 100%. |
| | 14 | EPID Ref Val | Output is based on the reference value of the external PID1 controller. Outputs 6.6 V in 100%. |
| 15 | EPID Fdb Val | Output is based on the feedback amount of the external PID1 controller. Outputs 6.6 V in 100%. | |
| OUT-02 AO1 Gain, OUT-03 AO1 Bias | <p>Adjusts output value and offset. If frequency is selected as an output item, it will operate as shown below.</p> $AO1 = \frac{Frequency}{MaxFreq} \times AO1\ Gain + AO1\ Bias$ <p>The graph below illustrates how the analog voltage output (AO1) changes depending on OUT-02 (AO1 Gain) and OUT-3 (AO1 Bias) values. The Y-axis is analog output voltage (0–10 V), and the X-axis is a % value of the output item.</p> | | |

Example, if the maximum frequency set at DRV-20 (Max Freq) is 60 Hz and the present output frequency is 30 Hz, then the x-axis value on the next graph is 50%.

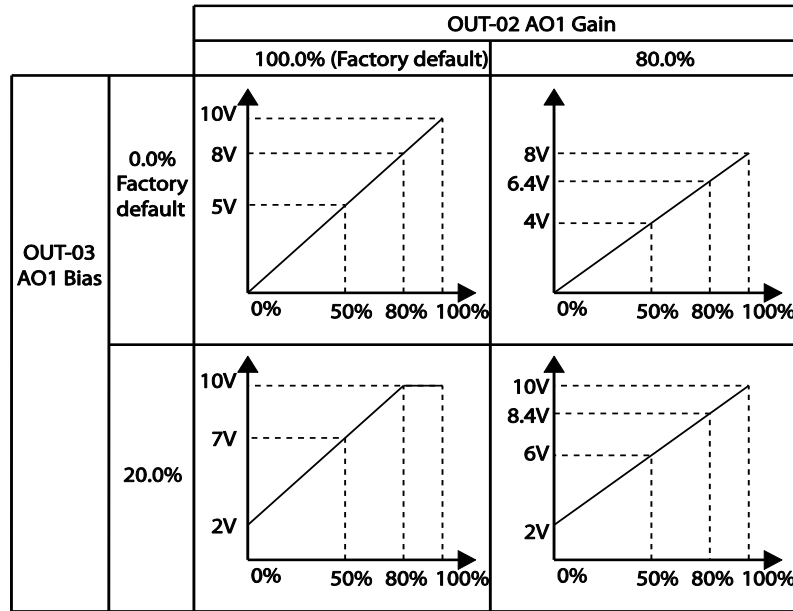

| | |
|--------------------|---|
| OUT-04 AO1 Filter | Set filter time constant on analog output. |
| OUT-05 AO1 Const % | If the analog output at OUT-01 (AO1 Mode) is set to '12 (Constant)', the analog voltage output is dependent on the set parameter values (0–100%). |
| OUT-06 AO1 Monitor | Monitors the analog output value. Displays the maximum output voltage as a percentage (%) with 10 V as the standard. |

Voltage and Current Analog Output Setting Details

5.47.2 Analog Pulse Output

Output item selection and pulse size adjustment can be made for the TO (Pulse Output) terminal.

| Group | Code | Name | LCD Display | Parameter Setting | Setting Range | Unit |
|-------|------|-------------------------------|-------------|-------------------|----------------|------|
| OUT | 61 | Pulse output setting | TO Mode | 0 Frequency | 0–15 | - |
| | 62 | Pulse output gain | TO Gain | 100.0 | -1000.0–1000.0 | - |
| | 63 | Pulse output bias | TO Bias | 1000.0 | -100.0–100.0 | - |
| | 64 | Pulse output filter | TO Filter | 5 | 0–10000 | - |
| | 65 | Pulse output constant output2 | TO Const % | 0.0 | 0.0–100.0 | % |
| | 66 | Pulse output monitor | TO Monitor | 0.0 | 0–1000.0 | % |

Analog Pulse Output Setting Details

| Code | Description |
|--------------------------------|---|
| OUT-62 TO Gain, OUT-63 TO Bias | <p>Adjusts output value and offset. If frequency is selected as an output, it will operate as shown below.</p> $TO = \frac{Frequency}{MaxFreq} \times TO\ Gain + TO\ Bias$ <p>The following graph illustrates that the pulse output (TO) changes depend on OUT-62 (TO Gain) and OUT-63 (TO Bias) values. The Y-axis is an analog output current (0–32 kHz), and X-axis is a % value of the output item.</p> <p>For example, if the maximum frequency set at DRV-20 (Max Freq) is 60 Hz and present output frequency is 30 Hz, then the x-axis value on the next graph is 50%.</p> |

| Code | Description | | | | | | | | | | | | | | | |
|-------------------|---|-------------------------|-------|----------------|--|--|--|-------------------------|-------|----------------|-------------------------|--|--|-------|--|--|
| | <table border="1" style="width: 100%; text-align: center;"> <thead> <tr> <th colspan="2"></th> <th colspan="2">OUT-61 TO Gain</th> </tr> <tr> <th colspan="2"></th> <th>100.0%(Factory default)</th> <th>80.0%</th> </tr> </thead> <tbody> <tr> <td rowspan="2" style="vertical-align: middle;">OUT-62 TO Bias</td> <td style="vertical-align: middle;">0.0% Factory default</td> <td> </td> <td> </td> </tr> <tr> <td style="vertical-align: middle;">20.0%</td> <td> </td> <td> </td> </tr> </tbody> </table> | | | OUT-61 TO Gain | | | | 100.0%(Factory default) | 80.0% | OUT-62 TO Bias | 0.0% Factory default | | | 20.0% | | |
| | | OUT-61 TO Gain | | | | | | | | | | | | | | |
| | | 100.0%(Factory default) | 80.0% | | | | | | | | | | | | | |
| OUT-62 TO Bias | 0.0% Factory default | | | | | | | | | | | | | | | |
| | 20.0% | | | | | | | | | | | | | | | |
| OUT-64 TO Filter | Sets filter time constant on analog output. | | | | | | | | | | | | | | | |
| OUT-65 TO Const % | If the analog output item is set to constant, the analog pulse output is dependent on the set parameter values. | | | | | | | | | | | | | | | |
| OUT-66 TO Monitor | Monitors the analog output value. It displays the maximum output pulse (32 kHz) as a percentage (%) of the standard. | | | | | | | | | | | | | | | |

NOTE

OUT-08 AO2 Gain and OUT-09 AO2 Bias Tuning Mode on 0–20 mA output

- 1 Set OUT-07 (AO2 Mode) to ‘constant’ and set OUT-11 (AO2 Const %) to 0.0 %.
- 2 Set OUT-09 (AO2 Bias) to 20.0% and then check the current output. 4 mA output should be displayed.
 - If the value is less than 4 mA, gradually increase OUT-09 (AO2 Bias) until 4 mA is measured.
 - If the value is more than 4 mA, gradually decrease OUT-09 (AO2 Bias) until 4 mA is measured.
- 3 Set OUT-11 (AO2 Const %) to 100.0%.
- 4 Set OUT-08 (AO2 Gain) to 80.0% and measure the current output at 20 mA.
 - If the value is less than 20 mA, gradually increase OUT-08 (AO2 Gain) until 20 mA is measured.
 - If the value is more than 20 mA, gradually decrease OUT-08 (AO2 Gain) until 20 mA is measured.

The functions for each code are identical to the descriptions for the 0–10 V voltage outputs with an output range 4–20 mA.

5.48 Digital Output

5.48.1 Multi-function Output Terminal and Relay Settings

| Group | Code | Name | LCD Display | Parameter Setting | | Setting Range | Unit |
|-------|-------|--------------------------------|---------------|-------------------|----------|-------------------------------|------|
| OUT | 31 | Multi-function relay 1 setting | Relay 1 | 23 | Trip | - | - |
| | 32 | Multi-function relay 2 setting | Relay 2 | 14 | Run | - | - |
| | 33 | Multi-function relay 3 setting | Relay 3 | 0 | None | - | - |
| | 34 | Multi-function relay 4 setting | Relay 4 | 0 | None | - | - |
| | 35 | Multi-function relay 5 setting | Relay 5 | 0 | None | - | - |
| | 36 | Multi-function output setting | Q1 define | 0 | None | - | - |
| | 41 | Multi-function output monitor | DO Status | - | - | 00–11 | bit |
| | 57 | Detection frequency | FDT Frequency | 30.00 | | 0.00– Maximum frequency | Hz |
| | 58 | Detection frequency band | FDT Band | 10.00 | | | |
| IN | 65–71 | Px terminal configuration | Px Define | 18 | Exchange | 0-55 | - |

Multi-function Output Terminal and Relay Setting Details

| Code | Description | | |
|-----------------------|---------------------------------------|-------|--|
| OUT-31–35 Relay1–5 | Set relay (Relay 1–5) output options. | | |
| | Setting | | Function |
| | 0 | None | No output signal |
| | 1 | FDT-1 | Detects inverter output frequency reaching the user set frequency. Outputs a signal when the |

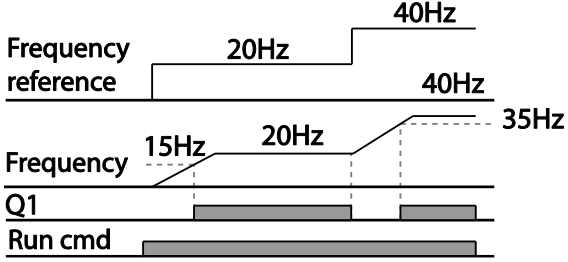
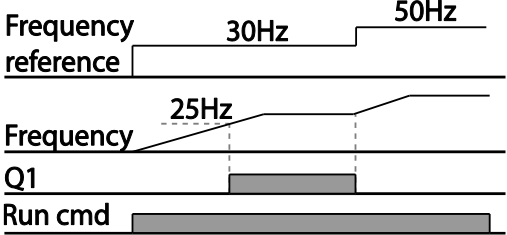
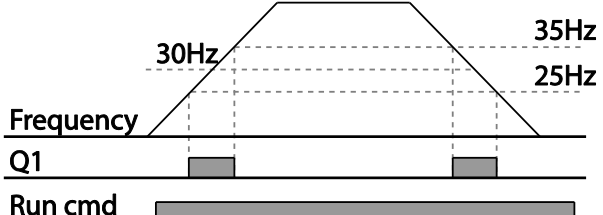
| | | |
|---|-------|---|
| | | <p>absolute value (set frequency–output frequency) < detected frequency width/2. When the detected frequency width is 10 Hz, FDT-1 output is as shown in the graph below.</p>  |
| 2 | FDT-2 | <p>Outputs a signal when the user-set frequency and detected frequency (FDT Frequency) are equal, and fulfills FDT-1 condition at the same time. [Absolute value (set frequency–detected frequency) < detected frequency width/2 & FDT-1] Detected frequency width is 10 Hz. When the detected frequency is set to 30 Hz, FDT-2 output is as shown in the graph below.</p>  |
| 3 | FDT-3 | <p>Outputs a signal when the Absolute value (output frequency–operation frequency) < detected frequency width/2. Detected frequency width is 10 Hz. When the detected frequency is set to 30 Hz, FDT-3 output is as shown in the graph below.</p>  |

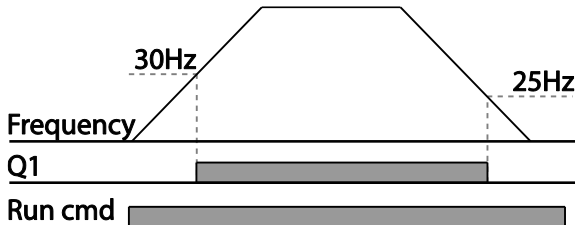
| | | |
|----|--------------|---|
| 4 | FDT-4 | <p>The output signal can be separately set for acceleration and deceleration conditions.</p> <ul style="list-style-type: none"> • In acceleration: Operation frequency \geq Detected frequency • In deceleration: Operation frequency $>$ (Detected frequency – Detected frequency width/2) <p>Detected frequency width is 10 Hz. When the detected frequency is set to 30 Hz, FDT-4 output is as shown in the graph below.</p>  |
| 5 | Over Load | Outputs a signal at motor overload. |
| 6 | IOL | Outputs a signal when the inverter input current exceeds the rated current and a protective function is activated to prevent damage to the inverter, based on inverse proportional characteristics. |
| 7 | Under Load | Outputs a signal at load fault warning. |
| 8 | Fan Warning | Outputs a signal at fan fault warning. |
| 9 | Stall | Outputs a signal when a motor is overloaded and stalled. |
| 10 | Over Voltage | Outputs a signal when the inverter DC link voltage rises above the protective operation voltage. |
| 11 | Low Voltage | Outputs a signal when the inverter DC link voltage drops below the low voltage protective level. |
| 12 | Over Heat | Outputs signal when the inverter overheats. |
| 13 | Lost Command | <p>Outputs a signal when there is a loss of analog input terminal and RS-485 communication command at the terminal block.</p> <p>Outputs a signal when communication power is present and an I/O expansion card is installed. It also outputs a signal when losing analog input and communication power commands.</p> |
| 14 | RUN | <p>Outputs a signal when an operation command is entered and the inverter outputs voltage.</p> <p>No signal output during DC braking.</p> |

| | | |
|----|----------------|---|
| | | <p>Frequency</p> <p>Q1</p> <p>Run cmd</p> |
| 15 | Stop | Outputs a signal at operation command off, and when there is no inverter output voltage. |
| 16 | Steady | Outputs a signal in steady operation. |
| 17 | Inverter Line | Outputs a signal while the motor is driven by the inverter line. |
| 18 | Comm Line | Outputs a signal when multi-function input terminal (switching) is entered. For details, refer to 5.31 Supply Power Transition page on 243 . |
| 19 | Speed Search | Outputs a signal during inverter speed search operation. For details, refer to 5.27 Speed Search Operation on page 234 . |
| 20 | Ready | Outputs a signal when the inverter is in stand by mode and ready to receive external operation commands. |
| 21 | MMC | Used as a multi-motor control function. By configuring the relay output and the multi-function output to MMC and configuring the AP1-40–AP1-92, it can conduct the necessary operations for multi-motor control function. |
| 22 | Timer Out | A timer function to operate terminal output after a certain time by using multi-function terminal block input. For details, refer to 5.43 Timer Settings on page 255 . |
| 23 | Trip | Outputs a signal after a fault trip. Refer to 5.45 Multi-function Output On/Off Control on page 259 . |
| 25 | DB Warn %ED | Refer to 0. Dynamic Braking (DB) Resistor Configuration on page 295 . |
| 26 | On/Off Control | Outputs a signal using an analog input value as a standard. Refer to 5.45 Multi-function Output On/Off Control on page 259 . |
| 27 | Fire Mode | Outputs a signal when Fire mode is in operation. |
| 28 | Pipe Break | Outputs a signal when a pipe is broken. |
| 29 | Damper Err | Outputs a signal when damper open signal is not entered. For more details, refer to 0 Damper Operation on page 187 . |
| 30 | Lubrication | Outputs a signal when a lubrication function is in operation. |

| | | | |
|------------------|--|----------------|---|
| | 31 | PumpClean Sel | Outputs a signal when a pump cleaning function is in operation. |
| | 32 | LDT Trip | Outputs a signal when an LDT trip occurs. |
| | 33 | Damper Control | Outputs a signal when a damper open signal is set at IN-65~71 multi-function terminals and run command is on. |
| | 34 | CAP.Warning | Outputs a signal when value of the PRT-85 is lower than the value of the PRT-86 (CAP life cycle examination do not operate properly). |
| | 35 | Fan Exchange | Outputs a signal when fan needs to be replaced. |
| | 36 | AUTO State | Outputs a signal in AUTO mode. |
| | 37 | HAND State | Outputs a signal in HAND mode. |
| | 38 | TO | Outputs a signal at pulse output. |
| | 39 | Except Date | Outputs a signal when operating the exception day schedule. |
| | 40 | KEB Operating | Outputs a signal at KEB operation. |
| | 41 | BrokenBelt | Outputs a signal when a Broken belt is in operation. |
| OUT-36 Q1 Define | Select an output item for the multi-function output terminal (Q1) of the terminal block. Q1 stands for the open collector TR output. | | |
| OUT-41 DO State | Used to check On/Off state of the D0 by each bit. | | |

⚠ Caution

- FDT-1 and FDT-2 functions are related to the frequency setting of the inverter. If the inverter enters standby mode by pressing the off key during auto mode operation, FDT-1 and FDT-2 function operation may be different because the set frequency of the inverter is different compared to the set frequency of the auto mode.
- If monitoring signals such as 'Under load' or 'LDT' are configured at multi-function output terminals, signal outputs are maintained unless certain conditions defined for signal cutoff are met.

5.48.2 Fault Trip Output using Multi-function Output Terminal and Relay

The inverter can output a fault trip state using the multi-function output terminal (Q1) and relay (Relay 1).

| Group | Code | Name | LCD Display | Parameter Setting | | Setting Range | Unit |
|-------|------|-----------------------------|----------------|-------------------|------|---------------|------|
| OUT | 30 | Fault trip output mode | Trip Out Mode | 010 | | - | bit |
| | 31 | Multi-function relay 1 | Relay 1 | 23 | Trip | - | - |
| | 32 | Multi-function relay 2 | Relay 2 | 14 | Run | - | - |
| | 33 | Multi-function relay 3 | Relay 3 | 0 | none | - | - |
| | 34 | Multi-function relay 4 | Relay 4 | 0 | none | - | - |
| | 35 | Multi-function relay 5 | Relay 5 | 0 | none | - | - |
| | 36 | Multi-function output1 | Q1 Define | 0 | none | - | - |
| | 53 | Fault trip output on delay | TripOut OnDly | 0.00 | | 0.00–100.00 | sec |
| | 54 | Fault trip output off delay | TripOut OffDly | 0.00 | | 0.00–100.00 | sec |

Fault Trip Output by Multi-function Output Terminal and Relay - Setting Details

| Code | Description | | | | | | | | | | | | | | | | | | |
|---|--|--------|--|----------|----------------|------|------|--|--|---|---|--|---|--|--|---|--|--|--|
| OUT-30 Trip Out Mode | Fault trip relay operates based on the fault trip output settings. | | | | | | | | | | | | | | | | | | |
| | <table border="1"> <thead> <tr> <th>Item</th> <th>bit on</th> <th>bit off</th> </tr> </thead> <tbody> <tr> <td>Keypad display</td> <td></td> <td></td> </tr> </tbody> </table> | Item | bit on | bit off | Keypad display | | | | | | | | | | | | | | |
| | Item | bit on | bit off | | | | | | | | | | | | | | | | |
| | Keypad display | | | | | | | | | | | | | | | | | | |
| | Select a fault trip output terminal/relay and select '29' (Trip Mode) at codes OUT- 31–33. When a fault trip occurs in the inverter, the relevant terminal and relay will operate. Depending on the fault trip type, terminal and relay operation can be configured as shown in the table below. | | | | | | | | | | | | | | | | | | |
| <table border="1"> <thead> <tr> <th colspan="3">Setting</th> <th rowspan="2">Function</th> </tr> <tr> <th>bit3</th> <th>bit2</th> <th>bit1</th> </tr> </thead> <tbody> <tr> <td></td> <td></td> <td>✓</td> <td>Operates when low voltage fault trips occur</td> </tr> <tr> <td></td> <td>✓</td> <td></td> <td>Operates when fault trips other than low voltage occur</td> </tr> <tr> <td>✓</td> <td></td> <td></td> <td>Operates when auto restart fails (PRT-08–09)</td> </tr> </tbody> </table> | Setting | | | Function | bit3 | bit2 | bit1 | | | ✓ | Operates when low voltage fault trips occur | | ✓ | | Operates when fault trips other than low voltage occur | ✓ | | | Operates when auto restart fails (PRT-08–09) |
| Setting | | | Function | | | | | | | | | | | | | | | | |
| bit3 | bit2 | bit1 | | | | | | | | | | | | | | | | | |
| | | ✓ | Operates when low voltage fault trips occur | | | | | | | | | | | | | | | | |
| | ✓ | | Operates when fault trips other than low voltage occur | | | | | | | | | | | | | | | | |
| ✓ | | | Operates when auto restart fails (PRT-08–09) | | | | | | | | | | | | | | | | |
| OUT-31–35 Relay1–5 | Set relay output (Relay 1–5). | | | | | | | | | | | | | | | | | | |
| OUT-36 Q1 Define | Select output for multi-function output terminal (Q1). Q1 is open collector TR output. | | | | | | | | | | | | | | | | | | |





5.48.3 Multi-function Output Terminal Delay Time Settings

Set on-delay and off-delay times separately to control the output terminal and relay operation times. The delay time set at codes OUT-50–51 applies to multi-function output terminal (Q1) and relay, except when the multi-function output function is in fault trip mode.

| Group | Code | Name | LCD Display | Parameter Setting | Setting Range | Unit |
|-------|------|---------------------------------------|--------------|-------------------|---------------|------|
| OUT | 50 | Multi-function output On delay | DO On Delay | 0.00 | 0.00–100.00 | sec |
| | 51 | Multi-function output Off delay | DO Off Delay | 0.00 | 0.00–100.00 | sec |
| | 52 | Select multi-function output terminal | DO NC/NO Sel | 000000* | 00–11 | bit |

*Multi-function output terminals are numbered. Starting from the right (number 1), the number increases to the left.

Output Terminal Delay Time Setting Details

| Code | Description | | | | | |
|---------------------------|--|---|---------------------------|--------------------------|----------------|---|
| OUT-50 DO On Delay | When a relay operation signal (operation set in OUT 31–35, 36) occurs, the relay turns on or the multi-function output operates after the time delay set at OUT-50. | | | | | |
| OUT-51 DO Off Delay | When relay or multi-function output is initialized (off signal occurs), the relay turns off or multi-function output turns off after the time delay set at OUT-54. | | | | | |
| OUT-52 DO NC/NO Sel | Select the terminal type for the relay and multi-function output terminal. By setting the relevant bit to '0,' it will operate A terminal (Normally Open). Setting it to '1' will operate B terminal (Normally Closed). Shown below in the table are Relay 1–5 and Q1 settings starting from the right bit. | | | | | |
| | <table border="1"> <thead> <tr> <th>Item</th> <th>B terminal (Normal close)</th> <th>A terminal (Normal open)</th> </tr> </thead> <tbody> <tr> <td>Keypad display</td> <td style="text-align: center;">  </td> <td style="text-align: center;">  </td> </tr> </tbody> </table> | Item | B terminal (Normal close) | A terminal (Normal open) | Keypad display |  |
| Item | B terminal (Normal close) | A terminal (Normal open) | | | | |
| Keypad display |  |  | | | | |

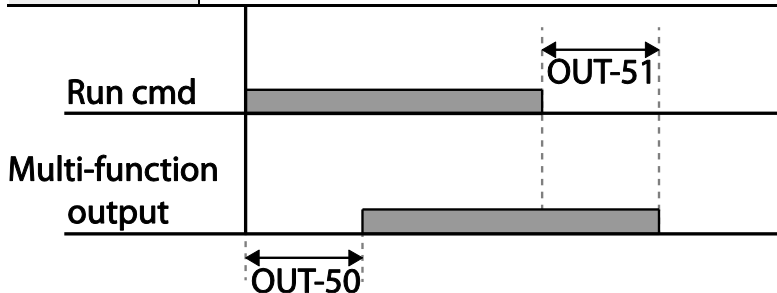

5.49 Operation State Monitor

The inverter’s operation condition can be monitored using the keypad. If the monitoring option is selected in config (CNF) mode, a maximum of four items can be monitored simultaneously. Monitoring mode displays three different items on the keypad, but only one item can be displayed in the status window at a time.

| Group | Code | Name | LCD Display | Parameter Setting | | Setting Range | Unit |
|-------|------|---------------------------------------|----------------|-------------------|----------------|---------------|------|
| CNF | 20 | Display item condition display window | AnyTime Para | 0 | Frequency | - | - |
| | 21 | Monitor mode display 1 | Monitor Line-1 | 0 | Frequency | - | Hz |
| | 22 | Monitor mode display 2 | Monitor Line-2 | 2 | Output Current | - | A |
| | 23 | Monitor mode display 3 | Monitor Line-3 | 3 | Output Voltage | - | V |
| | 24 | Monitor mode initialize | Mon Mode Init | 0 | No | - | - |

Operation State Monitor Setting Details

| Code | Description | | | | | | | | | | | | | | | | | | | | | | | | |
|------------------------|--|--|----------|---|--|---|--|---|--|---|--|---|--|---|---|---|---|---|---|---|--|---|---|----|---|
| CNF-20 AnyTime Para | Select items to display on the top-right side of the keypad screen. Choose the parameter settings based on the information to be displayed. Codes CNF-20–23 share the same setting options as listed below. | | | | | | | | | | | | | | | | | | | | | | | | |
| | <table border="1"> <thead> <tr> <th>Setting</th> <th>Function</th> </tr> </thead> <tbody> <tr> <td>0</td> <td>Frequency On stop, displays the set frequency. During operation, displays the actual output frequency (Hz).</td> </tr> <tr> <td>1</td> <td>Speed On stop, displays the set speed (rpm). During operation, displays the actual operating speed (rpm).</td> </tr> <tr> <td>2</td> <td>Output Current Displays output current.</td> </tr> <tr> <td>3</td> <td>Output Voltage Displays output voltage.</td> </tr> <tr> <td>4</td> <td>Output Power Displays output power.</td> </tr> <tr> <td>5</td> <td>WHour Counter Displays inverter power consumption.</td> </tr> <tr> <td>6</td> <td>DCLink Voltage Displays DC link voltage within the inverter.</td> </tr> <tr> <td>7</td> <td>DI Status Displays input terminal status of the terminal block. Starting from the right, displays P1–P8.</td> </tr> <tr> <td>8</td> <td>DO Status Displays output terminal status of the terminal block. Starting from the right: Relay1, Relay2, and Q1.</td> </tr> <tr> <td>9</td> <td>V1 Monitor[V] Displays the input voltage value at terminal V1 (V).</td> </tr> <tr> <td>10</td> <td>V1 Displays input voltage terminal V1 value as a</td> </tr> </tbody> </table> | Setting | Function | 0 | Frequency On stop, displays the set frequency. During operation, displays the actual output frequency (Hz). | 1 | Speed On stop, displays the set speed (rpm). During operation, displays the actual operating speed (rpm). | 2 | Output Current Displays output current. | 3 | Output Voltage Displays output voltage. | 4 | Output Power Displays output power. | 5 | WHour Counter Displays inverter power consumption. | 6 | DCLink Voltage Displays DC link voltage within the inverter. | 7 | DI Status Displays input terminal status of the terminal block. Starting from the right, displays P1–P8. | 8 | DO Status Displays output terminal status of the terminal block. Starting from the right: Relay1, Relay2, and Q1. | 9 | V1 Monitor[V] Displays the input voltage value at terminal V1 (V). | 10 | V1 Displays input voltage terminal V1 value as a |
| | Setting | Function | | | | | | | | | | | | | | | | | | | | | | | |
| | 0 | Frequency On stop, displays the set frequency. During operation, displays the actual output frequency (Hz). | | | | | | | | | | | | | | | | | | | | | | | |
| | 1 | Speed On stop, displays the set speed (rpm). During operation, displays the actual operating speed (rpm). | | | | | | | | | | | | | | | | | | | | | | | |
| | 2 | Output Current Displays output current. | | | | | | | | | | | | | | | | | | | | | | | |
| | 3 | Output Voltage Displays output voltage. | | | | | | | | | | | | | | | | | | | | | | | |
| | 4 | Output Power Displays output power. | | | | | | | | | | | | | | | | | | | | | | | |
| | 5 | WHour Counter Displays inverter power consumption. | | | | | | | | | | | | | | | | | | | | | | | |
| | 6 | DCLink Voltage Displays DC link voltage within the inverter. | | | | | | | | | | | | | | | | | | | | | | | |
| | 7 | DI Status Displays input terminal status of the terminal block. Starting from the right, displays P1–P8. | | | | | | | | | | | | | | | | | | | | | | | |
| 8 | DO Status Displays output terminal status of the terminal block. Starting from the right: Relay1, Relay2, and Q1. | | | | | | | | | | | | | | | | | | | | | | | | |
| 9 | V1 Monitor[V] Displays the input voltage value at terminal V1 (V). | | | | | | | | | | | | | | | | | | | | | | | | |
| 10 | V1 Displays input voltage terminal V1 value as a | | | | | | | | | | | | | | | | | | | | | | | | |

| Code | Description | |
|-----------------------------|--|--|
| | Monitor[%] | percentage. If -10 V, 0 V, +10 V is measured, -100%, 0%, 100% will be displayed. |
| 13 | V2 Monitor[V] | Displays input voltage terminal V2 value (V). |
| 14 | V2 Monitor[%] | Displays input voltage terminal V2 value as a percentage. |
| 15 | I2 Monitor[mA] | Displays input current terminal I2 value (A). |
| 16 | I2 Monitor[%] | Displays input current terminal I2 value as a percentage. |
| 17 | PID Output | Displays the PID controller output. |
| 18 | PID Ref Value | Displays the scale of the reference value and sets the value of PID reference. |
| 19 | PID Fdb Value | Displays the PID controller feedback volume. |
| 20 | EPID1 Mode | Displays the External PID1 mode. |
| 21 | EPID1 Output | Displays the External PID1 output value. |
| 23 | EPID1 Ref Val | Displays the External PID1 reference value. |
| CNF-21–23 Monitor Line-x | Select the items to be displayed in monitor mode. Monitor mode is the first mode displayed when the inverter is powered on. A total of three items, from monitor line-1 to monitor line- 3, can be displayed simultaneously. | |
| CNF-24 Mon Mode Init | Selecting '1 (Yes)' initializes CNF-20–23. | |

Note

Inverter power consumption

Values are calculated using voltage and current. Electric power is calculated every second and the results are accumulated. Setting CNF-62 (WH Count Reset) value to '1 (Yes)' will reset cumulated electric energy consumption. Power consumption is displayed as shown below:

- Less than 1,000 kW: Units are in kW, displayed in 999.9 kW format.
- 1–99 MW: Units are in MW, displayed in 99.99 MWh format.
- 100–999 MW: Units are in MW, displayed in 999.9 MWh format.
- More than 1,000 MW: Units are in MW, displayed in 9,999 MWh format and can be displayed up to 65,535 MW. (Values exceeding 65,535 MW will reset the value to 0, and units will return to kW. It will be displayed in 999.9 kW format).

5.50 Operation Time Monitor

This feature is used to monitor the inverter and fan operation times.

| Group | Code | Name | LCD Display | Parameter Setting | | Setting Range | Unit |
|-------|------|---|----------------|-------------------|----|---------------|--------------|
| CNF | 70 | Cumulated inverter power-on time | On-time | 00000DAY 00:00 | | - | Day hh:mm |
| | 71 | Cumulated inverter operation time | Run-time | 00000DAY 00:00 | | - | Day hh:mm |
| | 72 | Inverter operation accumulated time initialization | Time Reset | 0 | No | 0-1 | - |
| | 74 | Cooling fan operation accumulated time | Fan time | 00000DAY 00:00 | | - | Day hh:mm |
| | 75 | Cooling fan operation accumulated time initialization | Fan Time Reset | 0 | No | 0-1 | - |

Operation Time Monitor Setting Details

| Code | Description |
|-----------------------|---|
| CNF-70 On-time | Displays accumulated power supply time. Information is displayed in [Day Hr: Min (00000DAY 00:00)] format. |
| CNF-71 Run-time | Displays accumulated time of voltage output by operation command input. Information is displayed in [Day Hr: Min (00000DAY 00:00)] format. |
| CNF-72 Time Reset | Setting '1 (Yes)' will delete the power supply accumulated time (On-time) and operation accumulated time (Run-time) |
| CNF-74 Fan time | Displays accumulated time of the inverter cooling fan operation. Information will be displayed in [Day Hr: Min (00000DAY 00:00)] format. |
| CNF-75 Fan Time Reset | Setting '1 (Yes)' will delete the cooling fan operation accumulated time (Fan-time) |

5.51 PowerOn Resume Using the Communication

If there is a run command when recovering the power after instantaneous power interruption using communication (BAC net, LonWorks, Modbus RTU), the inverter carries out the run command which was set before the instantaneous power interruption.

| Group | Code | Name | LCD Display | Parameter Setting | | Setting Range | Unit |
|-------|------|--|----------------|-------------------|----|---------------|------|
| COM | 96 | Automatic restart of the communication restart | PowerOn Resume | 0 | No | 0-1 | - |

⚠ Caution

- If proper communication is unavailable after the instantaneous power interruption, even if the COM-96 PowerOn Resume function is set to 'Yes,' do not operate the inverter.
- The Power-on Run function operates separately (Power-on Run function and PowerOn Resume function is set to 'Yes' and power turns off and turns on, inverter maintains for the time set in Power-on run function and then, by the Power On Resume function, if the inverter is in operation by the communication command before the power interruptions, the inverter is in operation after the power recovery.)

5.52 Display current date / time / day using Multi key

The current date, time, and day of the week are displayed on the monitoring screen using the Multi key on the keypad.

| Group | Code | Name | LCD Display | Parameter Setting | | Setting Range | Unit |
|-------|------|----------------|---------------|-------------------|----------|---------------|------|
| CNF | 42 | Multi key item | Multi key sel | 2 | Now Time | 0-2 | - |

The current date is [AP3-01 Now Date], the current time is [AP3-02 Now Time], and the current day is the parameter value set in [AP3-03 Now Weekday].

When [CNF-42 Multi-Key Sel] is selected as {2: Now Time},  image is displayed on the top of the keypad.

When you press the <MULTI> key on the keypad, the image  is displayed on the top of the keypad, and the monitor display mode is changed to the monitor value automatically as follows: (Keypad parameters of Monitor Line 1/2/3 of CNF group is changed and only the display on the monitoring screen is changed)

Line1: Now Date (= value of AP3-01)

Line2: Now Time (= value of AP3-02)

Line3: Now Weekday (= value of AP3-03)

When you press <MULTI> key on the keypad again, (T) image is displayed on the top of the keypad, and the monitoring display value is changed to the state that the user has already set.

You can individually set {26: Now Date}, {27: Now Time} and {28: Now Weekday} in [CNF-21/22/23 Monitor Line-1/2/3]

[CNF-20 Anytime Money] can not be set to {26: Now Date} or {28: Now Weekday}.

6 Learning Protection Features

Protection features provided by the H100 series inverter are categorized into two types: protection from overheating damage to the motor and protection against the inverter malfunction.

6.1 Motor Protection

6.1.1 Electronic Thermal Motor Overheating Prevention (ETH)

ETH is a protective function that uses the output current of the inverter, without a separate temperature sensor, to predict a rise in motor temperature to protect the motor based on its heat characteristics.

| Group | Code | Name | LCD Display | Parameter Setting | | Setting range | Unit |
|-------|------|--|---------------|-------------------|-----------|---------------|------|
| PRT | 40 | Electronic thermal prevention fault trip selection | ETH Trip Sel | 0 | None | 0–2 | - |
| | 41 | Motor cooling fan type | Motor Cooling | 0 | Self-cool | - | - |
| | 42 | Electronic thermal one minute rating | ETH 1 min | 120 | | 100–150 | % |

Learning Protection Features

| Group | Code | Name | LCD Display | Parameter Setting | Setting range | Unit |
|-------|------|---|-------------|-------------------|---------------|------|
| | 43 | Electronic thermal prevention continuous rating | ETH Cont | 100 | 50–150 | % |

| Code | Description | | | | | | | | |
|--|---|---|----------|---|---|---|---|---|--|
| PRT-40 ETH Trip Sel | ETH can be selected to provide motor thermal protection. The LCD screen displays "E-Thermal." | | | | | | | | |
| | <table border="1"> <thead> <tr> <th>Setting</th> <th>Function</th> </tr> </thead> <tbody> <tr> <td>0</td> <td>None The ETH function is not activated.</td> </tr> <tr> <td>1</td> <td>Free-Run The inverter output is blocked. The motor coasts to a halt (free-run).</td> </tr> <tr> <td>2</td> <td>Dec The inverter decelerates the motor to a stop.</td> </tr> </tbody> </table> | Setting | Function | 0 | None The ETH function is not activated. | 1 | Free-Run The inverter output is blocked. The motor coasts to a halt (free-run). | 2 | Dec The inverter decelerates the motor to a stop. |
| | Setting | Function | | | | | | | |
| | 0 | None The ETH function is not activated. | | | | | | | |
| 1 | Free-Run The inverter output is blocked. The motor coasts to a halt (free-run). | | | | | | | | |
| 2 | Dec The inverter decelerates the motor to a stop. | | | | | | | | |
| Select the drive mode of the cooling fan, attached to the motor. | | | | | | | | | |
| PRT-41 Motor Cooling | <table border="1"> <thead> <tr> <th>Setting</th> <th>Function</th> </tr> </thead> <tbody> <tr> <td>0</td> <td>Self-cool As the cooling fan is connected to the motor axis, the cooling effect varies based on motor speed. Most universal induction motors have this design.</td> </tr> <tr> <td>1</td> <td>Forced-cool Additional power is supplied to operate the cooling fan. This provides extended operation at low speeds. Motors designed for inverters typically have this design.</td> </tr> </tbody> </table> | Setting | Function | 0 | Self-cool As the cooling fan is connected to the motor axis, the cooling effect varies based on motor speed. Most universal induction motors have this design. | 1 | Forced-cool Additional power is supplied to operate the cooling fan. This provides extended operation at low speeds. Motors designed for inverters typically have this design. | | |
| | Setting | Function | | | | | | | |
| | 0 | Self-cool As the cooling fan is connected to the motor axis, the cooling effect varies based on motor speed. Most universal induction motors have this design. | | | | | | | |
| 1 | Forced-cool Additional power is supplied to operate the cooling fan. This provides extended operation at low speeds. Motors designed for inverters typically have this design. | | | | | | | | |
| <p>Continuous rated current (%)</p> <p>Frequency (Hz)</p> | | | | | | | | | |
| PRT-42 ETH 1 min | The amount of input current that can be continuously supplied to the motor for 1 minute, based on the motor-rated current (BAS-13). | | | | | | | | |

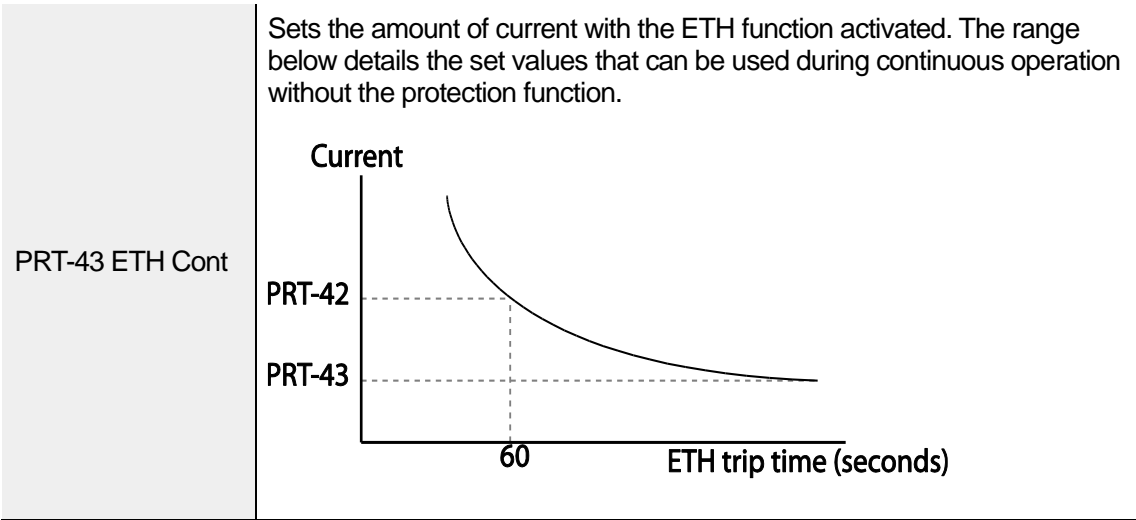

Electronic Thermal (ETH) Prevention Function Setting Details

6.1.2 Motor Over Heat Sensor

To operate the motor overheat protection, connect the overheat protection temperature sensor (PT 100, PTC) installed in the motor to the inverter’s analog input terminal.

| Group | Code | Name | LCD Display | Parameter Setting | | Setting Range | Unit |
|-------|------|--|----------------|-------------------|------------|---------------|------|
| | | | | | | | |
| PRT | 34 | Selecting the operation after the detection of the motor overheat detection sensor | Thermal-T Sel | 0 | None | 0-1 | - |
| | 35 | Selecting the input of the motor overheat detection sensor | Thermal In Src | 0 | Thermal In | 0-1 | |
| | 36 | Fault level of the motor overheat detection sensor | Thermal-T Lev | 50.0 | | 0.0-100.0 | % |
| | 37 | Fault area of the motor overheat detection sensor | Thermal-T Area | 0 | Low | 0-1 | |
| OUT | 07 | Analog output 2 item | AO2 Mode | 14 | Constant | 0-18 | |
| | 08 | Analog output 2 gain | AO2 Gain | 100 | | 0-100 | % |

Function Table

Motor Overheat Protect Sensor Input Detail Settings

| Code | Description | | |
|-------------------------------------|---|------------|--|
| PRT-34 Thermal-T Sel | Sets the inverter operation state when motor is overheated. | | |
| | Setting | Function | |
| | 0 | None | Do not operate when motor overheating is detected. |
| | 1 | Free-Run | When the motor is overheated, the inverter output is blocked and the motor will free-run by inertia. |
| | 3 | Dec | When the motor is over heated, the motor decelerates and stops. |
| PRT-35 Thermal In Src | Selects the type of the terminal when the motor overheat protect sensor is connected to the volt (V1) or current (I2) input terminal of the terminal block in the inverter. | | |
| | Setting | Function | |
| | 0 | Thermal In | Configure the motor overheat protect sensor connection to terminal block V1. |
| | 1 | V2 | Configure the motor overheat protect sensor connection to terminal block I2. |
| PRT-36 Thermal-T Lev | Configure the fault level of the motor overheat detect sensor. | | |
| PRT-37 Thermal-T Area | Setting | Function | |
| | 0 | Low | Operates when the motor overheat sensor input is smaller than PRT-36. |
| | 1 | High | Operates when the motor overheat sensor input is bigger that PRT-36. |
| OUT-07 AO2 Mode, OUT-08 AO2 Gain | Used when supplying the constant current to the temperature sensor and receives input through the I2 or V1 terminal block by using the analog output terminal. | | |

Using the temperature sensor (PTC) by connecting it to the analog input terminal

When the AO2(analog current output) terminal is connected to the temperature sensor installed on a motor, the inverter supplies constant current to the temperature sensor. Then,

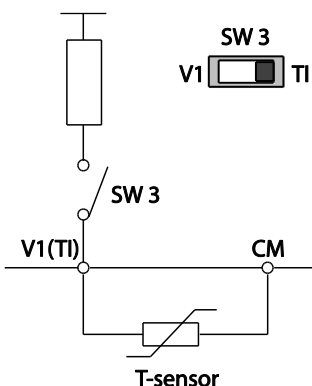

connecting the motor signal wire to one of the inverter’s analog input terminals allows the inverter to detect the changes in the PTC resistance and translates it into voltage. If the I2 terminal is used to receive the signal, set the selection switch on the I/O board to V2. If the V1 terminal is used, set the switch to T1. The sensor does not operate if SW3 is set to 'V1'.

To receive PTC signal at V1 input terminal, set PRT-35 (Thermal InSrc) to '0 (Thermal In)' and set the Analog1 input selection switch (SW3) to T1.

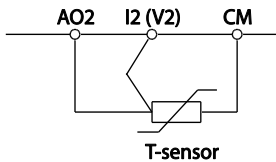
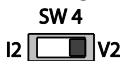

To receive PTC signal at I2 input terminal, set PRT-35 (Thermal InSrc) to '1 (V2)' and set SW 4 (Analog2 input selection switch) to V2. The sensor does not operate if SW4 is set to 'I2'. When the inverter detects a motor overload, motor overload trip occurs with internal delay time. The trip delay time is not reset instantly when the trip condition is released, but it only decreases as time passes.

6.1.3 Overload Early Warning and Trip

| Group | Code | Name | LCD Display | Parameter Setting | | Setting range | Unit |
|-------|------|----------------------------|----------------|-------------------|----------|---------------|------|
| PRT | 17 | Overload warning selection | OL Warn Select | 1 | Yes | 0-1 | - |
| | 18 | Overload warning level | OL Warn Level | 110 | | 30-120 | % |
| | 19 | Overload warning time | OL Warn Time | 10.0 | | 0-30 | sec |
| | 20 | Motion at overload trip | OL Trip Select | 1 | Free-Run | - | - |
| | 21 | Overload trip level | OL Trip Level | 120 | | 30-150 | % |
| | 22 | Overload trip time | OL Trip Time | 60.0 | | 0-60.0 | sec |

| | | | | | | | |
|-----|-------|-------------------------------|-----------|---|-----------|---|---|
| OUT | 31–35 | Multi-function relay 1–5 item | Relay 1–5 | 5 | Over Load | - | - |
| | 36 | Multi-function output 1 item | Q1 Define | | | | |

A warning or fault trip (cutoff) occurs when the motor reaches an overload state, based on the motor’s rated current. The amount of current for warnings and trips can be set separately.

Overload Early Warning and Trip Setting Details

| Code | Description | | |
|--|---|----------|---|
| PRT-17 OL Warn Select | If the overload reaches the warning level, the terminal block multi-function output terminal and relay are used to output a warning signal. If '1 (Yes)' is selected, it will operate. If '0 (No)' is selected, it will not operate. | | |
| PRT-18 OL Warn Level, PRT-19 OL Warn Time | When the input current to the motor is greater than the overload warning level (OL Warn Level) and continues at that level during the overload warning time (OL Warn Time), the multi-function output (Relay 1, Q1) sends a warning signal. When Over Load is selected at OUT-31, OUT-33, the multi-function output terminal or relay outputs a signal. The signal output does not block the inverter output. | | |
| PRT-20 OL Trip Select | Select the inverter protective action in the event of an overload fault trip. | | |
| | Setting | Function | |
| | 0 | None | No protective action is taken. |
| | 1 | Free-Run | In the event of an overload fault, inverter output is blocked and the motor will free-run due to inertia. |
| PRT-21 OL Trip Level, PRT-22 OL Trip Time | 3 | Dec | If a fault trip occurs, the motor decelerates and stops. |
| | When the current supplied to the motor is greater than the preset value of the overload trip level (OL Trip Level) and continues to be supplied during the overload trip time (OL Trip Time), the inverter output is either blocked according to the preset mode from PRT-17 or slows to a stop after deceleration. | | |

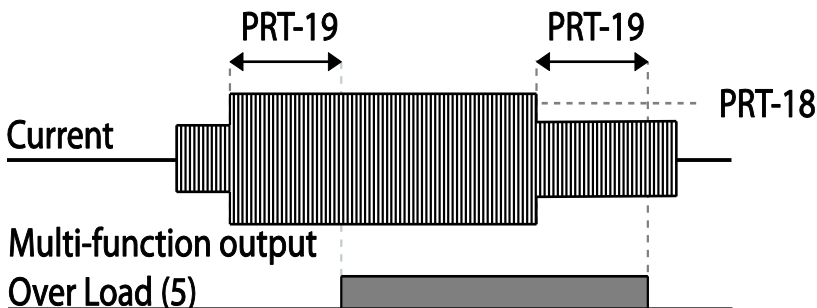

Note

Overload warnings warn of an overload before an overload fault trip occurs. The overload warning signal may not work in an overload fault trip situation, if the overload warning level (OL Warn Level) and the overload warning time (OL Warn Time) are set higher than the overload trip level (OL Trip Level) and the overload trip time (OL Trip Time).



6.1.4 Stall Prevention and Flux Braking

The stall prevention function is a protective function that prevents motors from stalling due to overloads. If a motor stall occurs due to an overload, the inverter operation frequency is adjusted automatically. When a stall is caused by overload, high currents induced in the motor may cause motor overheating or damage the motor and interrupt operation of the motor-driven devices.

In this case, the motor decelerates with optimum deceleration without a braking resistor by using flux braking. If the deceleration time is too short, an over voltage fault trip may occur because of regenerative energy from the motor. The flux braking makes the motor use regenerate energy, therefore optimum deceleration is available without over voltage fault trip.

To protect the motor from overload faults, the inverter output frequency is adjusted automatically, based on the size of load.

| Group | Code | Name | LCD Display | Parameter Setting | Setting range | Unit |
|-------|-------|-----------------------------------|---------------|-------------------|---|------|
| PRT | 50 | Stall prevention and flux braking | Stall Prevent | 0100 | - | bit |
| | 51 | Stall frequency 1 | Stall Freq 1 | 60.00 | Start Freq– Stall Freq 1 | Hz |
| | 52 | Stall level 1 | Stall Level 1 | 130 | 30–150 | % |
| | 53 | Stall frequency 2 | Stall Freq 2 | 60.00 | Stall Freq 1– Stall Freq 3 | Hz |
| | 54 | Stall level 2 | Stall Level 2 | 130 | 30–150 | % |
| | 55 | Stall frequency 3 | Stall Freq 3 | 60.00 | Stall Freq 2– Stall Freq 4 | Hz |
| | 56 | Stall level 3 | Stall Level 3 | 130 | 30–150 | % |
| | 57 | Stall frequency 4 | Stall Freq 4 | 60.00 | Stall Freq 3– Max Freq | Hz |
| | 58 | Stall level 4 | Stall Level 4 | 130 | 30–150 | % |
| | 59 | Flux Braking Gain | Flux Brake kp | 0 | 0.75- 90kW 0–150 110- 500kW 0–10 | - |
| OUT | 31–35 | Multi-function relay 1–5 item | Relay 1–5 | 9 | Stall | - |
| | 36 | Multi-function output 1 item | Q1 Define | | | |

| Code | Description | | | | | |
|----------------------|--|-------|--|-------|---|--|
| PRT-50 Stall Prevent | Stall prevention can be configured for acceleration, deceleration, or while operating a motor at constant speed. When the LCD segment is on, the corresponding bit is off. | | | | | |
| | Item | | Bit Status (On) | | Bit Status (Off) | |
| | Keypad display | |  | |  | |
| | Setting | | | | Function | |
| | Bit 4 | Bit 3 | Bit 2 | Bit 1 | | |
| | | | | ✓ | Stall protection during acceleration | |
| | | | ✓ | | Stall protection while operating at a constant speed | |
| | | ✓ | | | Stall protection during deceleration | |
| | ✓ | | | | Flux braking during deceleration | |
| | Setting | | | | Function | |
| 0001 | Stall protection during acceleration | | If inverter output current exceeds the preset stall level (PRT- 52, 54, 56, 58) during acceleration, the motor stops accelerating and starts decelerating. If current level stays above the stall level, the motor decelerates to the start frequency (DRV-19). If the current level causes deceleration below the preset level while operating the stall protection function, the motor resumes acceleration. | | | |
| 0010 | Stall protection while operating at constant speed | | Similar to stall protection function during acceleration, the output frequency automatically decelerates when the current level exceeds the preset stall level while operating at constant speed. When the load current decelerates below the preset level, it resumes acceleration. | | | |
| 0100 | Stall protection during deceleration | | The inverter decelerates and keeps the DC link voltage below a certain level to prevent an over voltage fault trip during deceleration. As a result, deceleration times can be longer than the set time depending on the load. | | | |
| 1000 | Flux braking | | When using flux braking, deceleration time | | | |

| | | |
|------|---|--|
| | during deceleration | may be reduced because regenerative energy is expended at the motor. |
| 1100 | Stall protection and flux braking during deceleration | Stall protection and flux braking operate together during deceleration to achieve the shortest and most stable deceleration performance. |

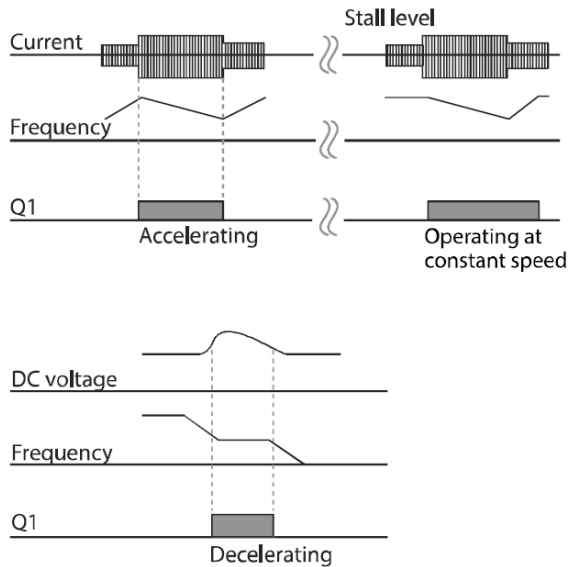

PRT-51 Stall Freq 1– PRT-58 Stall Level I4

Additional stall protection levels can be configured for different frequencies, based on the load type. As shown in the graph below, the stall level can be set above the base frequency. The lower and upper limits are set using numbers that correspond in ascending order. For example, the range for Stall Frequency 2 (Stall Freq 2) becomes the lower limit for Stall Frequency 1 (Stall Freq 1) and the upper limit for Stall Frequency 3 (Stall Freq 3).

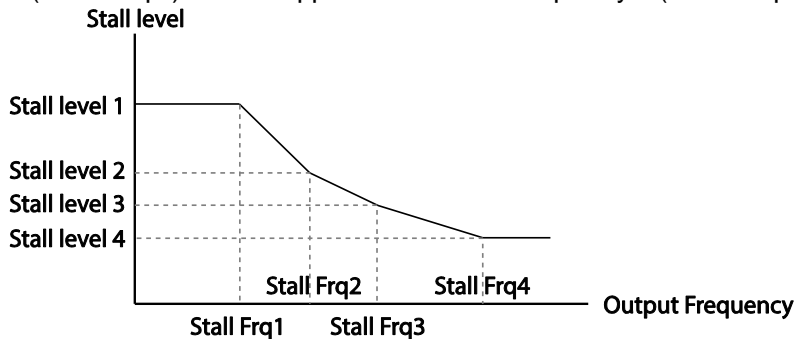

PRT-59 Flux Brake Kp

A gain used to decelerate without over voltage fault trip. It compensates for the inverter output voltage.

Stall Prevention Function and Flux Braking Setting Details

Note

Stall protection and flux braking operate together only during deceleration. Turn on the third and fourth bits of PRT-50 (Stall Prevention) to achieve the shortest and most stable deceleration performance without triggering an over voltage fault trip for loads with high inertia and short deceleration times. Do not use this function when frequent deceleration of the load is required, as the motor can overheat and be easily damaged.

⚠ Caution

- Use caution when decelerating while using stall protection since the deceleration time can take longer than the time set, depending on the load. Acceleration stops when stall protection operates during acceleration. This may make the actual acceleration time longer than the preset acceleration time.
- When the motor is operating, Stall Level 1 applies and determines the operation of stall protection.
- If the input voltage exceeds the nominal voltage, there is a possibility that the deceleration stall does not work properly.







6.2 Inverter and Sequence Protection

6.2.1 Open-phase Protection

Open-phase protection is used to prevent over current levels induced by the inverter inputs due to an open-phase within the input power supply. Open-phase output protection is also available. An open-phase at the connection between the motor and the inverter output may cause the motor to stall, due to a lack of torque.

| Group | Code | Name | LCD Display | Parameter Setting | Setting range | Unit |
|-------|------|------------------------------------|----------------|-------------------|---------------|------|
| PRT | 05 | Input/output open-phase protection | Phase Loss Chk | 00 | - | bit |
| | 06 | Open-phase input voltage band | IPO V Band | 40 | 1–100 V | V |

Input and Output Open-phase Protection Setting Details

| Code | Description | | | | | | | | | | |
|---|--|---|---|------------------|----------------|---|---|------------------------------|---|--|-----------------------------|
| PRT-05 Phase Loss Chk PRT-06 IPO V Band | When open-phase protection is operating, input and output configurations are displayed differently. When the LCD segment is On, the corresponding bit is set to 'Off'. | | | | | | | | | | |
| | <table border="1"> <thead> <tr> <th>Item</th> <th>Bit status (On)</th> <th>Bit status (Off)</th> </tr> </thead> <tbody> <tr> <td>Keypad display</td> <td></td> <td></td> </tr> </tbody> </table> | Item | Bit status (On) | Bit status (Off) | Keypad display |  |  | | | | |
| | Item | Bit status (On) | Bit status (Off) | | | | | | | | |
| | Keypad display |  |  | | | | | | | | |
| <table border="1"> <thead> <tr> <th colspan="2">Setting</th> <th rowspan="2">Function</th> </tr> <tr> <th>Bit 2</th> <th>Bit 1</th> </tr> </thead> <tbody> <tr> <td></td> <td>✓</td> <td>Output open-phase protection</td> </tr> <tr> <td>✓</td> <td></td> <td>Input open-phase protection</td> </tr> </tbody> </table> | Setting | | Function | Bit 2 | Bit 1 | | ✓ | Output open-phase protection | ✓ | | Input open-phase protection |
| Setting | | Function | | | | | | | | | |
| Bit 2 | Bit 1 | | | | | | | | | | |
| | ✓ | Output open-phase protection | | | | | | | | | |
| ✓ | | Input open-phase protection | | | | | | | | | |
| | | | | | | | | | | | |

6.2.2 External Trip Signal

Set one of the multi-function input terminals to 4 (External Trip) to allow the inverter to stop operation when abnormal operating conditions arise.

| Group | Code | Name | LCD Display | Parameter Setting | | Setting range | Unit |
|-------|-------|--|-----------------------|---|---------------|---------------|------|
| IN | 65–71 | Px terminal setting options | Px Define (Px: P1–P7) | 4 | External Trip | 0-55 | - |
| | 87 | Multi-function input contact selection | DI NC/NO Sel |  | | - | bit |

External Trip Signal Setting Details

| Code | Description | | | | | | | | | | | | | | | |
|--------------------|---|-----|----|----|----|----|----|---|---|----------|----|----|----|----|----|----|
| IN-87 DI NC/NO Sel | Selects the type of input contact. If the mark of the switch is at the bottom (0), it operates as an A contact (Normally Open). If the mark is at the top (1), it operates as a B contact (Normally Closed). The corresponding terminals for each bit are as follows: | | | | | | | | | | | | | | | |
| | <table border="1"> <thead> <tr> <th>Bit</th> <th>7</th> <th>6</th> <th>5</th> <th>4</th> <th>3</th> <th>2</th> <th>1</th> </tr> </thead> <tbody> <tr> <th>Terminal</th> <td>P7</td> <td>P6</td> <td>P5</td> <td>P4</td> <td>P3</td> <td>P2</td> <td>P1</td> </tr> </tbody> </table> | Bit | 7 | 6 | 5 | 4 | 3 | 2 | 1 | Terminal | P7 | P6 | P5 | P4 | P3 | P2 |
| Bit | 7 | 6 | 5 | 4 | 3 | 2 | 1 | | | | | | | | | |
| Terminal | P7 | P6 | P5 | P4 | P3 | P2 | P1 | | | | | | | | | |

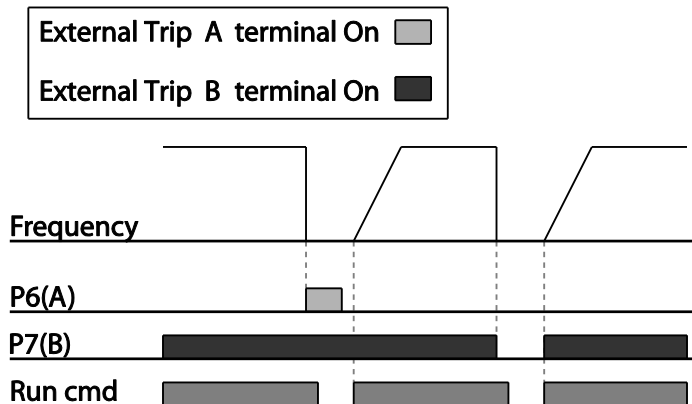

6.2.3 Inverter Overload Protection (IOLT)

When the inverter input current exceeds the rated current, a protective function is activated to prevent damage to the inverter, based on inverse proportional characteristics.

| Group | Code | Name | LCD Display | Parameter Setting | | Setting range | Unit |
|-------|-------|--------------------------|-------------|-------------------|-----|---------------|------|
| OUT | 31–35 | Multi-function relay 1–5 | Relay 1–5 | 6 | IOL | - | - |
| | 36 | Multi-function output 1 | Q1 Define | | | | |

Note

A warning signal output can be provided in advance by the multi-function output terminal before the inverter overload protection function (IOLT) operates. When the overcurrent time reaches 60% of the allowed overcurrent (120%, 1 min; 140%, 5 sec), a warning signal output is provided (signal output at 120%, 36 sec).

6.2.4 Speed Command Loss

When setting operation speed using an analog input at the terminal block, communication options, or the keypad, speed command loss setting can be used to select the inverter operation for situations when the speed command is lost due to the disconnection of signal cables.

| Group | Code | Name | LCD Display | Parameter Setting | | Setting range | Unit | |
|-------|---|------------------------------------|---------------|-------------------|--------------------------------|---------------|----------|---|
| PRT | 11 | Keypad command loss operation mode | Lost KPD Mode | 0 | None | 0 | None | - |
| | | | | | | 1 | Warning | |
| | | | | | | 2 | Free-Run | |
| | | | | | | 3 | Dec | |
| | 12 | Speed command loss operation mode | Lost Cmd Mode | 1 | Free-Run | - | - | |
| 13 | Time to determine speed command loss | Lost Cmd Time | 1.0 | | 0.1–120.0 | sec | | |
| 14 | Operation frequency at speed command loss | Lost Preset F | 0.00 | | Start frequency–Max. frequency | Hz | | |
| 15 | Analog input loss decision level | AI Lost Level | 0 | Half of x1 | | - | | |
| OUT | 31–35 | Multi-function Relay 1–5 | Relay 1–5 | 13 | Lost Command | - | - | |
| | 36 | Multi-function output 1 | Q1 Define | | | | | |

Speed Command Loss Setting Details

| Code | Description | | |
|---|---|--|---|
| PRT-11 Lost KPD Mode | Set the operation command source to keypad. If there is a communication error with the keypad or connection problem between the keypad and the inverter, select the inverter's operation. | | |
| | Setting | | Function |
| | 0 | None | The speed command immediately becomes the operation frequency without any protection function. |
| | 1 | Warning | Select 24: Lost keypad from OUT-31–36, one of the multi function terminal blocks, outputs a relevant warning signal when abnormal operating conditions arise. |
| | 2 | Free-Run | The inverter blocks output. The motor performs in free-run condition. |
| 3 | Dec | The motor decelerates and then stops at the time set at PRT-07 (Trip Dec Time). | |
| PRT-12 Lost Cmd Mode | In situations when speed commands are lost, the inverter can be configured to operate in a specific mode: | | |
| | Setting | | Function |
| | 0 | None | The speed command immediately becomes the operation frequency without any protection function. |
| | 1 | Free-Run | The inverter blocks output. The motor performs in free-run condition. |
| | 2 | Dec | The motor decelerates and then stops at the time set at PRT-07 (Trip Dec Time). |
| | 3 | Hold Input | The inverter calculates the average input value for 10 seconds before the loss of the speed command and uses it as the speed reference. |
| | 4 | Hold Output | The inverter calculates the average output value for 10 seconds before the loss of the speed command and uses it as the speed reference. |
| 5 | Lost Preset | The inverter operates at the frequency set at PRT-14 (Lost Preset F). | |
| PRT-15 AI Lost Level, PRT-13 Lst Cmd Time | Configure the voltage and decision time for speed command loss when using analog input. | | |
| | Setting | | Function |
| 0 | Half of x1 | Based on the values set at IN-08 and IN-12, a protective operation starts when the input signal is reduced to half of the initial value of the analog input set using the speed command (DRV-01) and it continues for the time (speed loss decision time) set at PRT-13 (Lost Cmd Time). For example, set the speed command to '2 (V1)' at DRV-07, and set IN- | |

| Code | Description | |
|----------------------|---|--|
| | | 06 (V1 Polarity) to '0 (Unipolar)'. When the voltage input drops to less than half of the value set at IN-08 (V1 Volt x 1), the protective function is activated. |
| | 1 | Below of x1 The protective operation starts when the signal becomes smaller than the initial value of the analog input set by the speed command and it continues for the speed loss decision time set at PRT-13 (Lost Cmd Time). Codes IN-08 and IN-12 are used to set the standard values. |
| | If the set value of the IN-08 and IN-12 is '0,' the LostCmd function does not operate. | |
| PRT-14 Lost Preset F | In situations where speed commands are lost, set the operation mode (PRT-12 Lost Cmd Mode) to '5 (Lost Preset)'. This operates the protection function and sets the frequency so that the operation can continue. | |

Set IN-06 (V1 Polarity) to 'Unipolar' and IN-08 to '5 (V)'. Set PRT-15 (AI Lost Level) to '1 (Below x1)' and PRT-12 (Lost Cmd Mode) to '2 (Dec)' and then set PRT-13 (Lost Cmd Time) to 5 seconds. Then the inverter operates as follows:

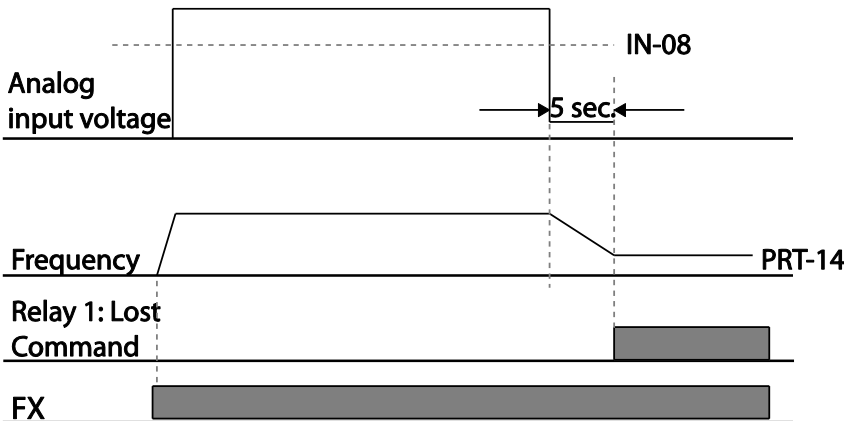

Note

If speed command is lost while using communication options or the integrated RS-485 communication, the protection function operates after the command loss decision time set at PRT-13 (Lost Cmd Time) is elapsed.

6.2.5 Dynamic Braking (DB) Resistor Configuration

For H100 series, the braking resistor circuit is integrated inside the inverter.

| Group | Code | Name | LCD Display | Parameter Setting | Setting range | Unit |
|-------|-------|--------------------------------|-------------|-------------------|---------------|------|
| PRT | 66 | Braking resistor configuration | DB Warn %ED | 0 | 0–30 | % |
| OUT | 31–35 | Multi-function relay 1–5 item | Relay 1–5 | 25 | DB Warn %ED | - |
| | 36 | Multi-function output 1 item | Q1 Define | | | |

Dynamic Braking Resistor Setting Details

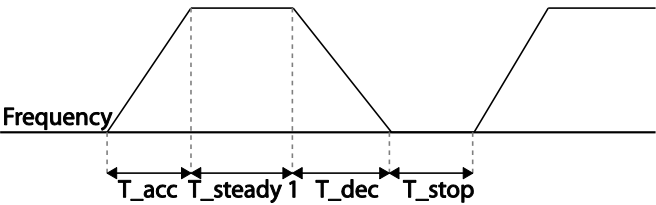
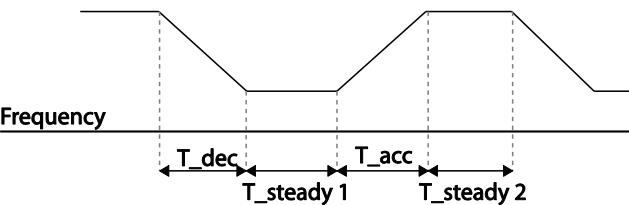
| Code | Description |
|--------------------|---|
| PRT-66 DB Warn %ED | <p>Set the braking resistor configuration (%ED: Enable Duty). The braking resistor configuration sets the rate at which the braking resistor operates for one operation cycle. The maximum time for continuous braking is 15 sec and the braking resistor signal is not output from the inverter after the 15 sec period elapses. An example of braking resistor set up is as follows: [Example 1]</p> $\%ED = \frac{T_{dec}}{T_{acc} + T_{steady} + T_{dec} + T_{stop}} \times 100\%$  <p>[Example 2]</p> $\%ED = \frac{T_{dec}}{T_{dec} + T_{steady1} + T_{acc} + T_{steady2}} \times 100\%$  <ul style="list-style-type: none"> T_acc: Acceleration time to set frequency |

| Code | Description |
|------|---|
| | <ul style="list-style-type: none"> T_steady: Constant speed operation time at set frequency T_dec: Deceleration time to a frequency lower than constant speed operation or the stop time from constant speed operation frequency T_stop: Stop time until operation resumes |

⚠ Caution

Do not set the braking resistor to exceed the resistor’s power rating. If overloaded; it can overheat and cause a fire. When using a resistor with a heat sensor, the sensor output can be used as an external trip signal for the inverter’s multi-function input.

6.2.6 Low Battery Voltage Warning

The H100 series has a battery low voltage warning feature. If the low battery voltage warning function is set to ‘Yes,’ a low battery voltage warning occurs when the battery voltage is lower than 2 V (normal voltage is 3 V). Replace the battery when the low battery warning is displayed.

| Group | Code | Name | LCD Display | Parameter Setting | | Setting Range | | Unit |
|-------|------|-------------------------------|-------------|-------------------|------|---------------|---------|------|
| PRT | 90 | Low battery voltage detection | Low Battery | 0 | None | 0 | None | - |
| | | | | | | 1 | Warning | |

Low Battery Voltage Warning Detail Settings

| Code | Description |
|--------------------|---|
| PRT-90 Low Battery | The low battery voltage warning for RTC function installed in the inverter can be enabled or disabled. The low battery voltage warning occurs when the battery voltage is lower than 2 V. |

⚠ Caution

- Be careful when replacing the battery. Remaining voltage in the battery may cause electric shock.
- Make sure that the battery doesn’t fall inside of the inverter.

6.3 Under load Fault Trip and Warning

The following table lists the under load fault trip and warning features of the H100 series inverter.

| Group | Code | Name | LCD Display | Parameter Setting | | Setting range | Unit |
|-------|------|------------------------------|--------------|-------------------|----------------|---------------|------|
| PRT | 23 | Under load detection Source | UL Source | 0 | Output Current | 0-1 | - |
| | 24 | Under load detection Band | UL Band | 10.0 | | 0.0-100.0 | % |
| | 25 | Under load warning selection | UL Warn Sel | 1 | Yes | 0-1 | - |
| | 26 | Under load warning time | UL Warn Time | 10.0 | | 0-600.0 | sec |
| | 27 | Under load trip selection | UL Trip Sel | 1 | Free-Run | 0-2 | - |
| | 28 | Under load trip timer | UL Trip Time | 30.0 | | 0-600.0 | sec |

Under Load Trip and Warning Setting Details

| Code | Description |
|------------------------|---|
| PRT-23 UL Source | Select a source to detect the under load trip. An under load trip can be detected using output current or output power. |
| PRT-24 UL Band | Make a standard value for the under load fault occurrence using system load%-UL Band value set in each frequency of the load characteristics curve made by the AP2-01 Load Tune. |
| PRT-25 UL Warn Sel | Select the under load warning options. Set the multi-function output terminals (at OUT-31-35 and 36) to '7' (Under load). The warning signals are output when under load conditions occur. |
| PRT-26 UL Warn Time | A protect function operates when under load level condition explained above maintains for the warning time set. |
| PRT-27 UL Trip Sel | Sets the inverter operation mode for situations when an under load trip occurs. If set to '1 (Free-Run)', the output is blocked in an under load fault trip event. If set to '2 (Dec)', the motor decelerates and stops when an under load trip occurs. |
| PRT-28 UL Trip Time | A protect function operates when under load level conditions explained above maintain for the trip time set. |

⚠ Caution

To operate under load trip properly, a load tuning (AP2-01 Load Tune) must be performed in advance. If you cannot perform a load tuning, manually set the load fit frequencies (AP2-02 Load Fit Lfreq-AP2-10 Load Fit Hfreq). The Under Load protection does not operate while the Energy Save function is in operation.

6.3.1 Fan Fault Detection

| Group | Code | Name | LCD Display | Parameter Setting | | Setting range | Unit |
|-------|-------|-----------------------------|---------------|-------------------|-------------|---------------|------|
| PRT | 79 | Cooling fan fault selection | Fan Trip Mode | Warning | | 0-1 | |
| OUT | 31-35 | Multi-function relay 1-5 | Relay 1-5 | 8 | Fan Warning | | - |
| OUT | 36 | Multi-function output 1 | Q1 Define | | | | |

* With a capacity of 110 kW or more, failure mode of internal fan is selected by selection of PRT-79.

Fan Fault Detection Setting Details

| Code | Description | |
|--------------------------------------|---|--|
| PRT-79 Fan Trip Mode | Set the cooling fan fault mode. | |
| | Setting | Function |
| | 0 | Trip |
| 1 | Warning | When OUT-36 (Q1 Define) and OUT-31-35 (Relay1-5) are set to '8 (FAN Warning)', the fan error signal is output and the operation continues. |
| OUT-36 Q1 Define, OUT-31-35 Relay1-5 | When the code value is set to '8 (FAN Warning)', the fan error signal is output and operation continues. However, when the inverter's inside temperature rises above a certain level, output is blocked due to activation of overheat protection. | |

6.3.2 Low Voltage Fault Trip

When inverter input power is lost and the internal DC link voltage drops below a certain voltage level, the inverter stops output and a low voltage trip occurs.

| Group | Code | Name | LCD Display | Parameter Setting | | Setting range | Unit |
|-------|-------|--------------------------------------|-------------|-------------------|-------------|---------------|------|
| PRT | 81 | Low voltage trip decision delay time | LVT Delay | 0.0 | | 0–60.0 | sec |
| OUT | 31–35 | Multi-function relay 1–5 | Relay 1–5 | 11 | Low Voltage | | - |
| | 36 | Multi-function output 1 | Q1 Define | | | | |

Low Voltage Fault Trip Setting Details

| Code | Description |
|---------------------|---|
| PRT-81 LVT Delay | If the code value is set to '11 (Low Voltage)', the inverter stops the output first when a low voltage trip condition occurs, then a fault trip occurs after the low voltage trip decision time elapses. The warning signal for a low voltage fault trip can be provided using the multi-function output or a relay. However, the low voltage trip delay time (LVT Delay time) does not apply to warning signals. |

6.3.3 Selecting Low Voltage 2 Fault During Operation

| Group | Code | Name | LCD Display | Setting | | Setting range | Unit |
|-------|------|--|--------------|---------|----|---------------|------|
| PRT | 82 | Low voltage trip decision during operation | LV2 Trip Sel | 0 | No | 0–1 | |

If input power is disconnected during inverter operation and internal DC voltage decreases lower than a certain voltage, the inverter disconnects the output and displays low voltage '2 (Low Voltage 2)'.

Even if the voltage increases and goes back to the normal state, unlike a low voltage fault, it remains in a fault state until the user unlocks the fault state.

6.3.4 Output Block via the Multi-function Terminal

When the multi-function input terminal is set as the output block signal terminal and the signal is input to the terminal, then the operation stops.

| Group | Code | Name | LCD Display | Parameter Setting | | Setting range | Unit |
|-------|-------|-----------------------------|-----------------------|-------------------|----|---------------|------|
| IN | 65–71 | Px terminal setting options | Px Define (Px: P1–P7) | 5 | BX | 0-55 | - |

Output Block by Multi-function Terminal Setting Details

| Code | Description |
|-----------------------|---|
| IN-65–71 Px Define | When the operation of the multi-function input terminal is set to '5 (BX)' and is turned on during operation, the inverter blocks the output and 'BX' is displayed on the keypad display. While 'BX' is displayed on the keypad screen, the inverter's operation information including the operation frequency and current at the time of the BX signal can be monitored. The inverter resumes operation when the BX terminal turns off and operation command is input. |

6.3.5 Trip Status Reset

Restart the inverter, using the keypad or analog input terminal, to reset the trip status.

| Group | Code | Name | LCD Display | Parameter Setting | | Setting range | Unit |
|-------|-------|-----------------------------|-----------------------|-------------------|-----|---------------|------|
| IN | 65–71 | Px terminal setting options | Px Define (Px: P1–P7) | 3 | RST | 0-55 | - |

Trip Status Reset Setting Details

| Code | Description |
|-----------------------|--|
| IN-65–71 Px Define | Press the [Stop/Reset] key on the keypad or use the multi-function input terminal to restart the inverter. Set the multi-function input terminal to '3' (RST) and turn on the terminal to reset the trip status. |

6.3.6 Operation Mode for Option Card Trip

Option card trips may occur when an option card is used with the inverter. Set the operation mode for the inverter when a communication error occurs between the option card and the inverter body, or when the option card is detached during operation.

| Group | Code | Name | LCD Display | Parameter Setting | | Setting range | Unit |
|-------|------|-------------------------------------|---------------|-------------------|----------|---------------|------|
| PRT | 80 | Operation mode for option card trip | Opt Trip Mode | 1 | Free-Run | 0–2 | - |

Operation Mode on Option Trip Setting Details

| Code | Description | | |
|-------------------------|-------------|----------|---|
| PRT-80 Opt Trip Mode | Setting | Function | |
| | 0 | None | No operation |
| | 1 | Free-Run | The inverter output is blocked and fault trip information is shown on the keypad. |
| | 2 | Dec | The motor decelerates to the value set at PRT-07 (Trip Dec Time). |

6.3.7 No Motor Trip

If an operation command is run when the motor is disconnected from the inverter output terminal, a 'no motor trip' occurs and a protective operation is performed by the system.

| Group | Code | Name | LCD Display | Parameter Setting | | Setting range | Unit |
|-------|------|-----------------------------|----------------|-------------------|------|---------------|------|
| PRT | 31 | Operation for no motor trip | No Motor Trip | 0 | None | 0-1 | - |
| | 32 | No motor trip current level | No Motor Level | 5 | | 1–100 | % |
| | 33 | No motor detection time | No Motor Time | 3.0 | | 0.1–10 | sec |

No Motor Trip Setting Details

| Code | Description |
|--|---|
| PRT-32 No Motor Level, PRT-33 No Motor Time | If the output current value [based on the rated current (BAS-13)] is lower than the value set at PRT-32 (No Motor Level), and if this continues for the time set at PRT-33 (No Motor Time), a 'no motor trip' occurs. |

⚠ Caution

If BAS-07 (V/F Pattern) is set to '1 (Square)', set PRT-32 (No Motor Level) to a value lower than the factory default. Otherwise, a 'no motor trip,' due to a lack of output current, will occur when the 'no motor trip' operation is set.

6.3.8 Broken Belt

It is a function to detect a problem in case that a Belt or Coupling is broken while a pump is used.

| Group | Code | Name | LCD Display | Parameter Setting | | Setting range | | Unit |
|-------|------|--|-----------------|-------------------|------|---------------|----------|------|
| PRT | 91 | Set broken belt function | BrokenBelt Sel | 0 | None | 0 | None | - |
| | | | | | | 1 | Warning | |
| | | | | | | 2 | Free-Run | |
| | 92 | Function frequency of broken belt | BrokenBelt Freq | 15.00 | | 15.00~MaxFreq | | Hz |
| | 93* | Motor torque current | Current Trq | - | | 0~100.0 | | % |
| | 94** | Function torque current of broken belt | BrokenBelt Trq | 10.0 | | 0~100.0 | | % |
| | 95 | Function Delay time of broken belt | BrokenBelt Dly | 10.0 | | 0.0~600.0 | | sec |

* Current output torque value compared to motor rated torque(%)

** Broken belt operation torque compared to motor rated torque(%)

After inverter is operating in the frequency over PRT-92 and current torque reaches the limit set at PRT-94 and then it meets the conditions at the time above set PRT-95, Broken Belt is activated.

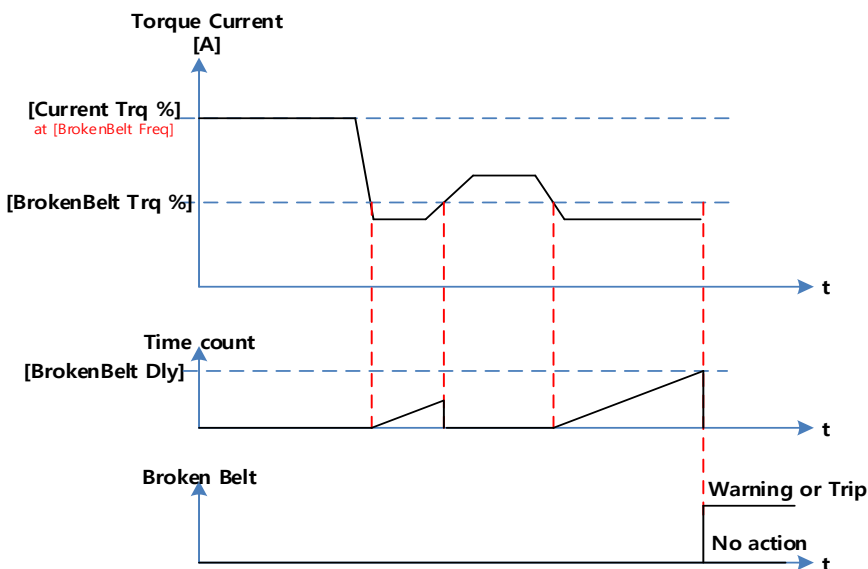

6.4 Parts Life Expectancy

Examine the life cycle of the parts (fan and main capacitor) of the inverter. By examining these parts you can use inverter more safely.

6.4.1 Main Capacitor Life Estimation

The life of the main capacitor in the inverter can be predicted by looking at the changes in the capacitance value.

| Group | Code | Name | LCD Display | Parameter Setting | | Setting Range | Unit | |
|-------|--------------------------|--|---------------|-------------------|-----------|---------------|-------------|---|
| PRT | 83 | Estimated current level of the capacitance | CAP.Diag Perc | 0.0 | | 10.0–100.0 | % | |
| | 84 | CAP estimating mode | CAP.Diag | 0 | None | 0 | None | % |
| | | | | | | 1 | CAP. Diag 1 | |
| | | | | | | 2 | CAP. Diag 2 | |
| | | | | | | 3 | CAP. Init | |
| 85 | CAP. deterioration level | CAP.Level1 | 0 | | 0.0–100.0 | % | | |
| 86 | CAP. detected level | CAP.Level2 | 0 | | 0.0–100.0 | % | | |
| OUT | 31–35 | Output relay 1–5 | Relay 1–5 | 34 | | CAP. Warning | - | |

Main Capacitor Life Estimation Detail Settings

| Code | Description | | | | | | | | | | |
|-----------------------|--|-------------|----------|---|------|---|-------------|---|-------------|---|-----------|
| PRT-83 CAP. Diag Perc | Configure the current level of the inverter's output when capacitance life examination is in operation. For life examination, the value must be set higher than 0%. | | | | | | | | | | |
| PRT-84 CAP. Diag | Configure the capacitance life examination mode. This mode is separated into installing the inverter mode and maintenance mode. To use the capacitance life examination function, proper setting is required. | | | | | | | | | | |
| | <table border="1"> <thead> <tr> <th>Setting</th> <th>Function</th> </tr> </thead> <tbody> <tr> <td>0</td> <td>None</td> </tr> <tr> <td>1</td> <td>CAP. Diag 1</td> </tr> <tr> <td>2</td> <td>CAP. Diag 2</td> </tr> <tr> <td>3</td> <td>CAP. Init</td> </tr> </tbody> </table> | Setting | Function | 0 | None | 1 | CAP. Diag 1 | 2 | CAP. Diag 2 | 3 | CAP. Init |
| | Setting | Function | | | | | | | | | |
| | 0 | None | | | | | | | | | |
| | 1 | CAP. Diag 1 | | | | | | | | | |
| 2 | CAP. Diag 2 | | | | | | | | | | |
| 3 | CAP. Init | | | | | | | | | | |
| 0 | None | | | | | | | | | | |
| 1 | Do not use capacitance life examination function. | | | | | | | | | | |
| 2 | When installing the inverter for the first time, estimate initial capacitance. | | | | | | | | | | |
| 3 | Estimate the capacitance while maintaining the inverter. | | | | | | | | | | |
| PRT-85 CAP. Level 1 | Set the standard level for the capacitance replacement. | | | | | | | | | | |
| PRT-86 CAP. Level 2 | Display estimated capacitance value according to the mode in PRT-84. If this value is lower than the value set in PRT-85, the warning message "CAP Warning" appears on the display. | | | | | | | | | | |

⚠ Caution

- Be careful when replacing the battery. Remaining voltage in the battery may cause electric shock.
- Make sure that the battery doesn't fall inside of the inverter.
- The main capacitor life examination is only for reference and cannot be used as an absolute value.
- The main capacitor life examination only operates in AUTO mode and when inverter is stopped.

6.4.2 Fan Life Estimation

The inverter records the amount of time the fan is used and sets off the alarm to replace the fan if the fan is used longer than the certain period of time.

| Group | Code | Name | LCD Display | Parameter Setting | | Setting Range | Unit |
|-------|-------|---|---------------|-------------------|--------------|---------------|------|
| PRT | 87 | Fan accumulated time percentage | Fan Time Perc | 0.0 | | - | % |
| | 88 | Fan replacement alarm level | Fan Exchange | 0.0 | | 0.0–100.0 | % |
| CNF | 75 | Initializing the accumulation time of the fan operation | Fan Time Rst | 0 | No | 0 | No |
| | | | | | | 1 | Yes |
| OUT | 31–35 | Relay 1–5 output | Relay 1–5 | 35 | Fan Exchange | 0-41 | - |

When PRT-88 value is 0%, Fan Exchange alarm does not occur and user can use the function when it is set to a value other than 0%.

Fan Life Estimation Setting Details

| Code | Description | | | | | | |
|--|---|--|--|---|-----|---|-----|
| PRT-87 Fan Time Perc | Displays the time the fan is used in percentage based on 50,000 hours. If this value is bigger than the value in PRT-88, the warning message "Fan Exchange" appears on the display. | | | | | | |
| PRT-88 Fan Exchange | Displays the life replacement standard of the fan in percentage. | | | | | | |
| CNF-75 Fan Time Rst | Initializes the accumulation time of the fan operation. | | | | | | |
| | <table border="1"> <thead> <tr> <th>Setting</th> <th>Function</th> </tr> </thead> <tbody> <tr> <td>0</td> <td>No</td> </tr> <tr> <td>1</td> <td>Yes</td> </tr> </tbody> </table> | Setting | Function | 0 | No | 1 | Yes |
| | Setting | Function | | | | | |
| 0 | No | | | | | | |
| 1 | Yes | | | | | | |
| <table border="1"> <tbody> <tr> <td>0</td> <td>No</td> <td>Do not initialize the accumulated operation time of the fan.</td> </tr> <tr> <td>1</td> <td>Yes</td> <td>Initialize the accumulated operation time of the fan.</td> </tr> </tbody> </table> | 0 | No | Do not initialize the accumulated operation time of the fan. | 1 | Yes | Initialize the accumulated operation time of the fan. | |
| 0 | No | Do not initialize the accumulated operation time of the fan. | | | | | |
| 1 | Yes | Initialize the accumulated operation time of the fan. | | | | | |

⚠ Caution

- Be careful when replacing the battery. Remaining voltage in the battery may cause electric shock.
- Make sure that the battery doesn't fall inside of the inverter.
- Fan life examination is only for the reference and cannot be used as an absolute value.

6.5 Fault/Warning List

The following list shows the types of faults and warnings that can occur while using the H100 inverter. For details, refer to 6 *Learning Protection Features* on page 307.

| Category | | LCD Display | Details |
|--------------|---------------------------|----------------|---|
| Major fault | Latch type | Over Current1 | Over current trip |
| | | Over Voltage | Over voltage trip |
| | | External Trip | Trip due to an external signal |
| | | NTC Open | Temperature sensor fault trip |
| | | Over Current2 | ARM short current fault trip |
| | | Option Trip-x* | Option fault trip* |
| | | Over Heat | Over heat fault trip |
| | | Out Phase Open | Output open-phase fault trip |
| | | In Phase Open | Input open-phase fault trip |
| | | Ground Trip | Ground fault trip |
| | | Fan Trip | Fan fault trip |
| | | E-Thermal | Motor overheat fault trip |
| | | IO Board Trip | IO Board connection fault trip |
| | | No Motor Trip | No motor fault trip |
| | | Low Voltage2 | Low voltage fault trip during operation |
| | | ParaWrite Trip | Write parameter fault trip |
| | | Pipe Broken | Pipe Break fault trip |
| | | Damper Err | Damper Err trip |
| | | Over Load | Motor overload fault trip |
| | | Under Load | Motor under load fault trip |
| | | CleanRPTErr | Pump clean trip |
| | | Level Detect | Level detect trip |
| | | MMC Interlock | MMC Interlock trip |
| Inverter OLT | Inverter overheating trip | | |
| Thermal Trip | Motor overheating trip | | |
| Lost Keypad | Lost keypad trip | | |

| | | | |
|----------------|-------------------------|---------------------------------------|---------------------------------|
| | | Broken Belt | Broken belt trip |
| | | Pipe Broken | Pipe Broken trip |
| | | Fuse Open | Fuse Open trip (315~500kW) |
| | | InFAN Trip | Inner Fan trip (110~500kW) |
| | Level type | Low Voltage | Low voltage fault trip |
| | | BX | Emergency stop fault trip |
| | | Lost Command | Command loss trip |
| | | Lost Keypad | Lost keypad trip |
| | Hardware damage (Fatal) | EEP Err | External memory error |
| | | ADC Off Set | Analog input error |
| | | IO Board Trip | IO Board connection fault trip |
| | | Watch Dog-1 | CPU Watch Dog fault trip |
| | | Watch Dog-2 | |
| | Warning | Lost Command | Command loss fault trip warning |
| | | Over Load | Overload warning |
| Under Load | | Under load warning | |
| Inv Over Load | | Inverter overload warning | |
| Fan Warning | | Fan operation warning | |
| DB Warn %ED | | Braking resistor braking rate warning | |
| Low Battery | | Low battery warning | |
| Fire Mode | | Fire mode warning | |
| Pipe Broken | | Pipe Break warning | |
| Level Detect | | Level detect warning | |
| CAP. Warning | | Capacitor lifetime warning | |
| Fan Exchange | | Fan replacement warning | |
| Lost Keypad | | Lost keypad warning | |
| Load Tune | | Load curve tuning warning | |
| Broken Belt | | Broken belt warning | |
| ParaWrite Fail | | Smart copier error warning | |
| Rs Tune Err | | Auto tuning warning(Rs) | |
| Lsig Tune Err | | Auto tuning warning(Lsigma) | |

| | | |
|--|---------------|-------------------------------|
| | InFAN Warning | Inner Fan Warning (110~500kW) |
|--|---------------|-------------------------------|

Note

- In a latch type trip, the inverter cannot unlock the fault if the user does not reset the inverter, even if the trip state is released after the trip occurs.
- In level type trip, the inverter can unlock the fault by itself if the trip state is unlocked after the trip occurs.
- In a fetal type trip, there is no way to unlock the fault other than turning the inverter off then back on after the trip occurs.

7 RS-485 Communication Features

This section in the user manual explains how to control the inverter with a PLC or a computer over a long distance using the RS-485 communication features. To use the RS-485 communication features, connect the communication cables and set the communication parameters on the inverter. Refer to the communication protocols and parameters to configure and use the RS-485 communication features.

7.1 Communication Standards

Following the RS-485 communication standards, H100 products exchange data with a PLC and computer. The RS-485 communication standards support the Multi-drop Link System and offer an interface that is strongly resistant to noise. Please refer to the following table for details about the communication standards.

| Item | Standard |
|--|---|
| Communication method/ Transmission type | RS-485/Bus type, Multi-drop Link System |
| Inverter type name | H100 |
| Number of connected inverters/ Transmission distance | Maximum of 16 inverters / Maximum 1,200 m (recommended distance: within 700 m) |
| Recommended cable size | 0.75 mm ² , (18 AWG), Shielded Type Twisted-Pair (STP) Wire |
| Installation type | Dedicated terminals (S+/S-/SG) on the control terminal block |
| Power supply | Supplied by the inverter - insulated power source from the inverter's internal circuit |
| Communication speed | 1,200/2,400/4800/9,600/19,200/38,400/57,600/115,200 bps BACNET: 9600/19200/38400/76800 bps |
| Control procedure | Asynchronous communications system |
| Communication system | Half duplex system |
| Character system | Modbus-RTU: Binary / LS Bus: ASCII |
| Stop bit length | 1-bit/2-bit |
| Frame error check | 2 bytes |
| Parity check | None/Even/Odd |

7.2 Communication System Configuration

In an RS-485 communication system, the PLC or computer is the master device and the inverter is the slave device. When using a computer as the master, the RS-232 converter must be integrated with the computer, so that it can communicate with the inverter through the RS-232/RS-485 converter. Specifications and performance of converters may vary depending on the manufacturer, but the basic functions are identical. Please refer to the converter manufacturer's user manual for details about features and specifications.

Connect the wires and configure the communication parameters on the inverter by referring to the following illustration of the communication system configuration.

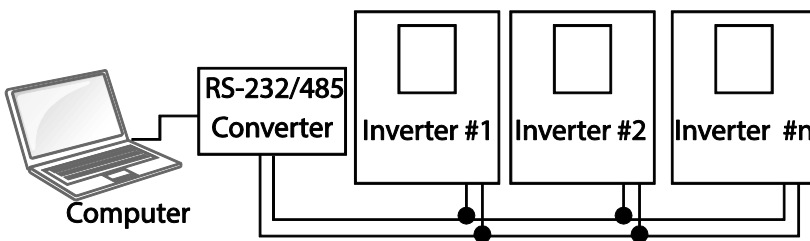

7.2.1 Communication Line Connection

Make sure that the inverter is turned off completely, and then connect the RS-485 communication line to the S+/S-/SG terminals of the terminal block. The maximum number of inverters you can connect is 16. For communication lines, use shielded twisted pair (STP) cables.

The maximum length of the communication line is 1,200 meters, but it is recommended to use no more than 700 meters of communication line to ensure stable communication. Please use a repeater to enhance the communication speed when using a communication line longer than 1,200 meters or when using a large number of devices. A repeater is effective when smooth communication is not available due to noise interference.

⚠ Caution

When wiring the communication line, make sure that the SG terminals on the PLC and inverter are connected. SG terminals prevent communication errors due to electronic noise interference.

7.2.2 Setting Communication Parameters

Before proceeding with setting communication configurations, make sure that the communication lines are connected properly. Turn on the inverter and set the communication parameters.

| Group | Code | Name | LCD Display | Parameter Setting | | Setting range | Unit |
|-------|------|--------------------------------------|--------------|-------------------|------------|-----------------------------|------|
| COM | 01 | Built-in communication inverter ID | Int485 St ID | 1 | | 1– MaxComID ⁷ | - |
| | 02 | Built-in communication protocol | Int485 Proto | 0 | ModBus RTU | 0-6 | - |
| | 03 | Built-in communication speed | Int485 BaudR | 3 | 9600 bps | 0–8 | - |
| | 04 | Built-in communication frame setting | Int485 Mode | 0 | D8/PN/S1 | 0–3 | - |
| | 05 | Transmission delay after reception | Resp Delay | 5 | | 0–1000 | msec |

Communication Parameters Setting Details

| Code | Description | | | | | | | | | | | | |
|---------------------|--|---------------------|---------------------|---|------------|---|------------|---|--------|---|------------|---|---------------|
| COM-01 Int485 St ID | Sets the inverter station ID between 1 and MaxComID. | | | | | | | | | | | | |
| COM-02 Int485 Proto | Select one of the four built-in protocols: Modbus-RTU, LS INV 485, BACnet or Metasys-N2. | | | | | | | | | | | | |
| | <table border="1"> <thead> <tr> <th>Setting</th> <th>Function</th> </tr> </thead> <tbody> <tr> <td>0</td> <td>Modbus-RTU</td> </tr> <tr> <td>2</td> <td>LS INV 485</td> </tr> <tr> <td>4</td> <td>BACnet</td> </tr> <tr> <td>5</td> <td>Metasys-N2</td> </tr> <tr> <td>6</td> <td>ModBus Master</td> </tr> </tbody> </table> | Setting | Function | 0 | Modbus-RTU | 2 | LS INV 485 | 4 | BACnet | 5 | Metasys-N2 | 6 | ModBus Master |
| | Setting | Function | | | | | | | | | | | |
| | 0 | Modbus-RTU | | | | | | | | | | | |
| | 2 | LS INV 485 | | | | | | | | | | | |
| | 4 | BACnet | | | | | | | | | | | |
| | 5 | Metasys-N2 | | | | | | | | | | | |
| 6 | ModBus Master | | | | | | | | | | | | |
| 0 | Modbus-RTU | | | | | | | | | | | | |
| 2 | LS INV 485 | | | | | | | | | | | | |
| 4 | BACnet | | | | | | | | | | | | |
| 5 | Metasys-N2 | | | | | | | | | | | | |
| 6 | ModBus Master | | | | | | | | | | | | |
| COM-03 Int485 BaudR | Set a communication setting speed up to 115,200 bps. The maximum setting range changes depending on the protocol. | | | | | | | | | | | | |
| | <table border="1"> <thead> <tr> <th>Setting</th> <th>Communication Speed</th> </tr> </thead> <tbody> <tr> <td>0</td> <td>1200 bps</td> </tr> </tbody> </table> | Setting | Communication Speed | 0 | 1200 bps | | | | | | | | |
| | Setting | Communication Speed | | | | | | | | | | | |
| 0 | 1200 bps | | | | | | | | | | | | |
| 0 | 1200 bps | | | | | | | | | | | | |

⁷ If AP1-40 is set to '4(Serve Drv)', MaxComID is '8', and if COM-02 is set to '4(BACnet), MaxComID is '127'. Otherwise MaxComID is '250'.

| Code | Description | | | | | | | | | | | | | | | | |
|--------------------|---|--|----------|----------|----------|----------|---|---|-----------|--|-----------|----------|---------------------------------------|---|------------------------|--------------------------------------|--------------------------|
| | <table border="1"> <tr><td>1</td><td>2400 bps</td></tr> <tr><td>2</td><td>4800 bps</td></tr> <tr><td>3</td><td>9600 bps</td></tr> <tr><td>4</td><td>19200 bps</td></tr> <tr><td>5</td><td>38400 bps</td></tr> <tr><td>6</td><td>56 Kbps (57,600 bps)</td></tr> <tr><td>7</td><td>76.8 Kbps (76,800 bps)</td></tr> <tr><td>8</td><td>115.2 Kbps (115,200 bps)</td></tr> </table> <p>If the COM-02 Int485 Proto setting is BACnet, the available communication speed settings are 9600 bps, 19200 bps, 76.8 kbps. If the COM-02 Int485 Proto setting is Metasys-N2, the communication speed is fixed to 9600 bps and COM-03 Int485 BaudR is not shown.</p> | 1 | 2400 bps | 2 | 4800 bps | 3 | 9600 bps | 4 | 19200 bps | 5 | 38400 bps | 6 | 56 Kbps (57,600 bps) | 7 | 76.8 Kbps (76,800 bps) | 8 | 115.2 Kbps (115,200 bps) |
| 1 | 2400 bps | | | | | | | | | | | | | | | | |
| 2 | 4800 bps | | | | | | | | | | | | | | | | |
| 3 | 9600 bps | | | | | | | | | | | | | | | | |
| 4 | 19200 bps | | | | | | | | | | | | | | | | |
| 5 | 38400 bps | | | | | | | | | | | | | | | | |
| 6 | 56 Kbps (57,600 bps) | | | | | | | | | | | | | | | | |
| 7 | 76.8 Kbps (76,800 bps) | | | | | | | | | | | | | | | | |
| 8 | 115.2 Kbps (115,200 bps) | | | | | | | | | | | | | | | | |
| COM-04 Int485 Mode | <p>Set a communication configuration. Set the data length, parity check method, and the number of stop bits.</p> <table border="1"> <thead> <tr> <th>Setting</th> <th></th> <th>Function</th> </tr> </thead> <tbody> <tr> <td>0</td> <td>D8/PN/S1</td> <td>8-bit data / no parity check / 1 stop bit</td> </tr> <tr> <td>1</td> <td>D8/PN/S2</td> <td>8-bit data / no parity check / 2 stop bits</td> </tr> <tr> <td>2</td> <td>D8/PE/S1</td> <td>8-bit data / even parity / 1 stop bit</td> </tr> <tr> <td>3</td> <td>D8/PO/S1</td> <td>8-bit data / odd parity / 1 stop bit</td> </tr> </tbody> </table> <p>If the COM-02 Int485 Proto setting is Metasys-N2, the communication frame composition is fixed to D8/PN/S1 and COM-04 Int485 Mode is not visible.</p> | Setting | | Function | 0 | D8/PN/S1 | 8-bit data / no parity check / 1 stop bit | 1 | D8/PN/S2 | 8-bit data / no parity check / 2 stop bits | 2 | D8/PE/S1 | 8-bit data / even parity / 1 stop bit | 3 | D8/PO/S1 | 8-bit data / odd parity / 1 stop bit | |
| Setting | | Function | | | | | | | | | | | | | | | |
| 0 | D8/PN/S1 | 8-bit data / no parity check / 1 stop bit | | | | | | | | | | | | | | | |
| 1 | D8/PN/S2 | 8-bit data / no parity check / 2 stop bits | | | | | | | | | | | | | | | |
| 2 | D8/PE/S1 | 8-bit data / even parity / 1 stop bit | | | | | | | | | | | | | | | |
| 3 | D8/PO/S1 | 8-bit data / odd parity / 1 stop bit | | | | | | | | | | | | | | | |
| COM-05 Resp Delay | <p>Set the response time for the slave (inverter) to react to the request from the master. Response time is used in a system where the slave device response is too fast for the master device to process. Set this code to an appropriate value for smooth master-slave communication.</p> <p>The diagram illustrates the timing between a Master and a Slave. The Master sends a 'Request' pulse. The Slave responds with a 'Response' pulse. The time interval between the start of the Master's Request and the start of the Slave's Response is indicated by a double-headed arrow and labeled 'COM-5 Resp Delay'. This delay is shown for two consecutive requests and responses.</p> | | | | | | | | | | | | | | | | |

7.2.3 Setting Operation Command and Frequency

After setting the DRV-06 Cmd Source code to '3 (Int 485)' and DRV-07 Freq Ref Src code to '6 (Int 485)', you can set common area parameters for the operation command and frequency via communication. For details about the operation command, refer to [4.6.4 RS-485 Communication as a Command Input Device](#) on page 106 and about the frequency command, refer to [4.2.6 Setting a Frequency Reference via RS-485 Communication](#) on page 99.

To select the built-in RS485 communication as the source of command, set DRV-07 to '6 (Int485)' on the keypad. Then, set common area parameters for the operation command and frequency via communication.

| Group | Code | Name | LCD Display | Parameter Setting | | Setting range | Unit |
|-------|------|--------------------------|--------------|-------------------|---------|---------------|------|
| DRV | 06 | Command source | Cmd Source | 3 | Int 485 | 0-5 | - |
| | 07 | Frequency setting method | Freq Ref Src | 6 | Int 485 | 0-11 | - |

7.2.4 Command Loss Protective Operation

Configure the command loss decision standards and protective operations run when a communication problem lasts for a specified period of time.

| Group | Code | Name | LCD Display | Parameter Setting | | Setting range | Unit |
|-------|------|--------------------------------------|---------------|-------------------|------|---------------|------|
| PRT | 12 | Speed command loss operation mode | Lost Cmd Mode | 0 | None | 0-5 | - |
| | 13 | Time to determine speed command loss | Lost Cmd Time | 6 | 1.0 | 0.1-120.0 | sec |

Command Loss Protective Operation Setting Details

| Code | Description | | |
|---|--|---|--|
| PRT-12 Lost Cmd Mode, PRT-13 Lost Cmd Time | Select the operation to run when a communication error has occurred and lasted exceeding the time set at PRT-13. | | |
| | Setting | Function | |
| | 0 | None | The speed command immediately becomes the operation frequency without any protection function. |
| | 1 | Free-Run | The inverter blocks output. The motor performs in free-run condition. |
| | 2 | Dec | The motor decelerates and then stops. |
| | 3 | Hold Input | Operates continuously with the speed of the inputted speed command until the loss of the speed command. The inverter calculates the average input value for 10 seconds before the loss of the speed command and uses it as the speed reference. |
| | 4 | Hold Output | Operates continuously with the operate frequency before the speed loss. The inverter calculates the average output value for 10 seconds before the loss of the speed command and uses it as the speed reference. |
| 5 | Lost Preset | The inverter operates at the frequency set at PRT-14 (Lost Preset F). | |

7.3 LS INV 485/Modbus-RTU Communication

7.3.1 Setting Virtual Multi-function Input

Multi-function input can be controlled using a communication address (0h0385). Set codes COM-70–77 to the functions to operate, and then set the BIT relevant to the function to 1 at 0h0385 to operate it. Virtual multi-function operates independently from IN-65–71 analog multi-function inputs and cannot be set redundantly. Virtual multi-function input can be monitored using COM-86 (Virt DI Status). Before you configure the virtual multi-function inputs, set the DRV code according to the command source.

| Group | Code | Name | LCD Display | Parameter Setting | | Setting range | Unit |
|-------|-------|---|-----------------------|-------------------|------|-----------------------|------|
| COM | 70–77 | Communication multi-function input x | Virtual DI x (x: 1–8) | 0 | None | 0–55 | - |
| | 86 | Communication multi-function input monitoring | Virt DI Status | 0000 0000 | | 0000 0000 – 1111 1111 | bit |

Example: When sending an Fx command by controlling virtual multi-function input in the common area via Int485, set COM-70 to 'FX' and set address 0h0385 to '0h0001'.

7.3.2 Saving Parameters Defined by Communication

If you turn off the inverter after setting the common area parameters or keypad parameters via communication and operate the inverter, the changes are lost and the values changed via communication revert to the previous setting values when you turn on the inverter.

Set CNF-48 to '1 (Yes)' to allow all the changes over communication to be saved, so that the inverter retains all the existing values even after the power has been turned off.

Setting address 0h03E0 to '0' and then setting it again to '1' via communication allows the existing parameter settings to be saved. However, setting address 0h03E0 to '1' and then

| Group | Code | Name | LCD Display | Parameter Setting | | Setting range | | Unit |
|-------|------|-----------------|----------------|-------------------|----|---------------|-----|------|
| CNF | 48 | Save parameters | Parameter Save | 0 | No | 0 | No | - |
| | | | | | | 1 | Yes | |

setting it to '0' does not carry out the same function.

7.3.3 Total Memory Map for Communication

| Communication Area | Memory Map | Details |
|--------------------------------------|---------------|--|
| Communication common compatible area | 0h0000–0h00FF | iS5, iP5A, iV5, iG5A, S100, H100 compatible area |
| Parameter registration type area | 0h0100–0h01FF | Areas registered at COM-31–38 and COM-51–58 |
| | 0h0200–0h023F | Area registered for User Group |
| | 0h0240–0h027F | Area registered for Macro Group |
| | 0h0280–0h02FF | Reserved |
| Communication common area | 0h0300–0h037F | Inverter monitoring area |
| | 0h0380–0h03DF | Inverter control area |
| | 0h03E0–0h03FF | Inverter memory control area |
| | 0h0400–0h0FFF | Reserved |
| | 0h1100 | DRV Group |
| | 0h1200 | BAS Group |
| | 0h1300 | ADVGroup |
| | 0h1400 | CON Group |
| | 0h1500 | IN Group |
| | 0h1600 | OUT Group |
| | 0h1700 | COM Group |
| | 0h1800 | PID Group |
| | 0h1900 | EPI Group |
| | 0h1A00 | AP1 Group |
| | 0h1B00 | AP2 Group |
| | 0h1C00 | AP3 Group |
| | 0h1D00 | PRT Group |
| | 0h1E00 | M2 Group |

7.3.4 Parameter Group for Data Transmission

By defining a parameter group for data transmission, the communication addresses registered in the communication function group (COM) can be used in communication. Parameter group for data transmission may be defined to transmit multiple parameters at once, into the communication frame.

| Group | Code | Name | LCD Display | Parameter Setting | Setting range | Unit |
|-------|-------|--------------------------------|-------------------------|-------------------|---------------|------|
| COM | 31–38 | Output communication address x | Para Status-x (x: 1–8) | - | 0000–FFFF | Hex |
| | 51–58 | Input communication address x | Para Control-x (x: 1–8) | - | 0000–FFFF | Hex |

Currently Registered CM Group Parameter

| Address | Parameter | Assigned content by bit |
|---------------|---|--|
| 0h0100–0h0107 | Status Parameter-1– Status Parameter-8 | Parameter communication code value registered at COM-31–38 (Read-only) |
| 0h0110–0h0117 | Control Parameter-1– Control Parameter-8 | Parameter communication code value registered at COM-51–58 (Read/Write access) |

Note

When registering control parameters, register the operation speed (0h0005, 0h0380, 0h0381) and operation command (0h0006, 0h0382) parameters at the end of a parameter control frame. For example, when the parameter control frame has 5 parameter control items (Para Control - x), register the operation speed at Para Control-4 and the operation command to Para Control-5.

7.3.5 Parameter Group for User/Macro Group

By defining user/macro parameter groups, communication can be carried out using the user defined group (USR Grp) and macro group (MAC Grp) addresses that are registered at the U&M mode. Parameter groups can only be defined when using the keypad.

Currently Registered User Group Parameters

| Address | Parameter | Assigned Content by Bit |
|---------|-------------------|---|
| 0h0200 | User Grp. Code 1 | Parameter value registered at U&M > USR → 1 (Read/Write) |
| 0h0201 | User Grp. Code 2 | Parameter value registered at U&M > USR → 2 (Read/Write) |
| · | · | · |
| · | · | · |
| · | · | · |
| 0h023E | User Grp. Code 63 | Parameter value registered at U&M > USR → 63 (Read/Write) |
| 0h023F | User Grp. Code 64 | Parameter value registered at U&M > USR → 64 (Read/Write) |

Currently Registered Macro Group Parameters

| Address | Parameter | Assigned Content by Bit |
|---------|--------------------|---|
| 0h0240 | Macro Grp. Code 1 | Parameter value registered at U&M > MC → 1 |
| 0h0241 | Macro Grp. Code 2 | Parameter value registered at U&M > MC → 1 |
| · | · | · |
| · | · | · |
| · | · | · |
| 0h02A2 | Macro Grp. Code 98 | Parameter value registered at U&M > MC → 98 |
| 0h02A3 | Macro Grp. Code 99 | Parameter value registered at U&M > MC → 99 |

7.3.6 LS INV 485 Protocol

The slave device (inverter) responds to read and write requests from the master device (PLC or PC).

Request

| ENQ | Station ID | CMD | Data | SUM | EOT |
|--------|------------|--------|---------|---------|--------|
| 1 byte | 2 bytes | 1 byte | n bytes | 2 bytes | 1 byte |

Normal Response

| ACK | Station ID | CMD | Data | SUM | EOT |
|--------|------------|--------|-------------|---------|--------|
| 1 byte | 2 bytes | 1 byte | n x 4 bytes | 2 bytes | 1 byte |

Error Response

| NAK | Station ID | CMD | Error code | SUM | EOT |
|--------|------------|--------|------------|---------|--------|
| 1 byte | 2 bytes | 1 byte | 2 bytes | 2 bytes | 1 byte |

- A request starts with ENQ and ends with EOT.
- A normal response starts with ACK and ends with EOT.
- An error response starts with NAK and ends with EOT.
- A station ID indicates the inverter number and is displayed as a two-byte ASCII-HEX string that uses characters 0-9 and A-F.
- CMD: Uses uppercase characters (returns an IF error if lowercase characters are encountered)—please refer to the following table.

| Character | ASCII-HEX | Command |
|-----------|-----------|------------------------------|
| 'R' | 52h | Read |
| 'W' | 57h | Write |
| 'X' | 58h | Request monitor registration |
| 'Y' | 59h | Perform monitor registration |

- Data: ASCII-HEX (for example, when the data value is 3000: 3000 → '0"B"B"8'h → 30h 42h 42h 38h)
- Error code: ASCII-HEX (refer to [7.3.6.4 Error Code](#) on page [353](#))
- Transmission/reception buffer size: Transmission=39 bytes, Reception=44 bytes
- Monitor registration buffer: 8 Words
- SUM: Checks communication errors via sum.
- SUM=a total of the lower 8 bits values for station ID, command and data (Station ID+CMD+Data) in ASCII-HEX.
- For example, a command to read 1 address from address 3000:
SUM='0'+ '1'+ 'R'+ '3'+ '0'+ '0'+ '0'+ '1' = 30h+31h+52h+33h+30h+30h+30h+31h = 1A7h
(the control value is not included: ENQ, ACK, NAK, etc)

| ENQ | Station ID | CMD | Address | Number of Addresses | SUM | EOT |
|--------|------------|--------|---------|---------------------|---------|--------|
| 05h | '01' | 'R' | '3000' | '1' | 'A7' | 04h |
| 1 byte | 2 bytes | 1 byte | 4 bytes | 1 byte | 2 bytes | 1 byte |

Note

Broadcasting

Broadcasting sends commands to all inverters connected to the network simultaneously. When commands are sent from station ID 255, each inverter acts on the command regardless of the station ID. However no response is issued for commands transmitted by broadcasting

7.3.6.1 Detailed Read Protocol

Read Request: Reads successive n words from address XXXX.

| ENQ | Station ID | CMD | Address | Number of Addresses | SUM | EOT |
|--------|------------|--------|---------|---------------------|---------|--------|
| 05h | '01'-'FA' | 'R' | 'XXXX' | '1'-'8' = n | 'XX' | 04h |
| 1 byte | 2 bytes | 1 byte | 4 bytes | 1 byte | 2 bytes | 1 byte |

Total bytes=12. Characters are displayed inside single quotation marks(').

Read Normal Response

| ACK | Station ID | CMD | Data | SUM | EOT |
|--------|------------|--------|-------------|---------|--------|
| 06h | '01'-'FA' | 'R' | 'XXXX' | 'XX' | 04h |
| 1 byte | 2 bytes | 1 byte | n x 4 bytes | 2 bytes | 1 byte |

Total bytes= (7 x n x 4): a maximum of 39

Read Error Response

| NAK | Station ID | CMD | Error code | SUM | EOT |
|--------|------------|--------|------------|---------|--------|
| 15h | '01'-'FA' | 'R' | '**' | 'XX' | 04h |
| 1 byte | 2 bytes | 1 byte | 2 bytes | 2 bytes | 1 byte |

Total bytes=9

7.3.6.2 Detailed Write Protocol**Write Request**

| ENQ | Station ID | CMD | Address | Number of Addresses | Data | SUM | EOT |
|--------|------------|--------|---------|---------------------|-------------|---------|--------|
| 05h | '01'-'FA' | 'W' | 'XXXX' | '1'-'8' = n | 'XXXX...' | 'XX' | 04h |
| 1 byte | 2 bytes | 1 byte | 4 bytes | 1 byte | n x 4 bytes | 2 bytes | 1 byte |

Total bytes= (12 + n x 4): a maximum of 44

Write Normal Response

| ACK | Station ID | CMD | Data | SUM | EOT |
|--------|------------|--------|-------------|---------|--------|
| 06h | '01'-'FA' | 'W' | 'XXXX...' | 'XX' | 04h |
| 1 byte | 2 bytes | 1 byte | n x 4 bytes | 2 bytes | 1 byte |

Total bytes= (7 + n x 4): a maximum of 39

Write Error Response

| NAK | Station ID | CMD | Error Code | SUM | EOT |
|--------|------------|--------|------------|---------|--------|
| 15h | '01'-'FA' | 'W' | '**' | 'XX' | 04h |
| 1 byte | 2 bytes | 1 byte | 2 bytes | 2 bytes | 1 byte |

Total bytes=9

7.3.6.3 Monitor Registration Detailed Protocol

Monitor registration request is made to designate the type of data that requires continuous monitoring and periodic updating.

Monitor Registration Request: Registration requests for n addresses (where n refers to the number of addresses. The addresses do not have to be contiguous.)

| ENQ | Station ID | CMD | Number of Addresses | Address | SUM | EOT |
|--------|------------|--------|---------------------|-------------|---------|--------|
| 05h | '01'-'FA' | 'X' | '1'-'8'=n | 'XXXX...' | 'XX' | 04h |
| 1 byte | 2 bytes | 1 byte | 1 byte | n x 4 bytes | 2 bytes | 1 byte |

Total bytes= (8 + n x 4): a maximum of 40

Monitor Registration Normal Response

| ACK | Station ID | CMD | SUM | EOT |
|--------|------------|--------|---------|--------|
| 06h | '01'-'FA' | 'X' | 'XX' | 04h |
| 1 byte | 2 bytes | 1 byte | 2 bytes | 1 byte |

Total bytes=7

Monitor Registration Error Response

| NAK | Station ID | CMD | Error Code | SUM | EOT |
|--------|------------|--------|------------|---------|--------|
| 15h | '01'-'FA' | 'X' | '**' | 'XX' | 04h |
| 1 byte | 2 bytes | 1 byte | 2 bytes | 2 bytes | 1 byte |

Total bytes=9

Monitor Registration Perform Request: A data read request for a registered address, received from a monitor registration request

| ENQ | Station ID | CMD | SUM | EOT |
|--------|------------|--------|---------|--------|
| 05h | '01'-'FA' | 'Y' | 'XX' | 04h |
| 1 byte | 2 bytes | 1 byte | 2 bytes | 1 byte |

Total bytes=7

Monitor Registration Execution Normal Response

| ACK | Station ID | CMD | Data | SUM | EOT |
|--------|------------|--------|-------------|---------|--------|
| 06h | '01'-'FA' | 'Y' | 'XXXX...' | 'XX' | 04h |
| 1 byte | 2 bytes | 1 byte | n x 4 bytes | 2 bytes | 1 byte |

Total bytes = (7 + n x 4): a maximum of 39

Monitor Registration Execution Error Response

| NAK | Station ID | CMD | Error Code | SUM | EOT |
|--------|------------|--------|------------|---------|--------|
| 15h | '01'-'FA' | 'Y' | '**' | 'XX' | 04h |
| 1 byte | 2 bytes | 1 byte | 2 bytes | 2 bytes | 1 byte |

Total bytes=9

7.3.6.4 Error Code

| Code | Abbreviation | Description |
|----------------------|--------------|---|
| ILLEGAL FUNCTION | IF | The requested function cannot be performed by a slave because the corresponding function does not exist. |
| ILLEGAL DATA ADDRESS | IA | The received parameter address is invalid at the slave. |
| ILLEGAL DATA VALUE | ID | The received parameter data is invalid at the slave. |
| WRITE MODE ERROR | WM | Tried writing (W) to a parameter that does not allow writing (read-only parameters, or when writing is prohibited during operation) |
| FRAME ERROR | FE | The frame size does not match. |

7.3.6.5 ASCII Code

| Character | Hex | Character | Hex | Character | Hex |
|-----------|-----|-----------|-----|-----------|-----|
| A | 41 | q | 71 | @ | 40 |
| B | 42 | r | 72 | [| 5B |
| C | 43 | s | 73 | \ | 5C |
| D | 44 | t | 74 |] | 5D |
| E | 45 | u | 75 | | 5E |

| Character | Hex | Character | Hex | Character | Hex |
|-----------|-----|-----------|-----|-----------|-----|
| F | 46 | v | 76 | | 5F |
| G | 47 | w | 77 | | 60 |
| H | 48 | x | 78 | { | 7B |
| I | 49 | y | 79 | | 7C |
| J | 4A | z | 7A | } | 7D |
| K | 4B | 0 | 30 | - | 7E |
| L | 4C | 1 | 31 | BEL | 07 |
| M | 4D | 2 | 32 | BS | 08 |
| N | 4E | 3 | 33 | CAN | 18 |
| O | 4F | 4 | 34 | CR | 0D |
| P | 50 | 5 | 35 | DC1 | 11 |
| Q | 51 | 6 | 36 | DC2 | 12 |
| R | 52 | 7 | 37 | DC3 | 13 |
| S | 53 | 8 | 38 | DC4 | 14 |
| T | 54 | 9 | 39 | DEL | 7F |
| U | 55 | space | 20 | DLE | 10 |
| V | 56 | ! | 21 | EM | 19 |
| W | 57 | " | 22 | ACK | 06 |
| X | 58 | # | 23 | ENQ | 05 |
| Y | 59 | \$ | 24 | EOT | 04 |
| Z | 5A | % | 25 | ESC | 1B |
| a | 61 | & | 26 | ETB | 17 |
| b | 62 | ' | 27 | ETX | 03 |
| c | 63 | (| 28 | FF | 0C |
| d | 64 |) | 29 | FS | 1C |
| e | 65 | * | 2A | GS | 1D |
| f | 66 | + | 2B | HT | 09 |
| g | 67 | , | 2C | LF | 0A |
| h | 68 | - | 2D | NAK | 15 |
| i | 69 | . | 2E | NUL | 00 |
| j | 6A | / | 2F | RS | 1E |
| k | 6B | : | 3A | S1 | 0F |
| l | 6C | ; | 3B | SO | 0E |
| m | 6D | < | 3C | SOH | 01 |
| n | 6E | = | 3D | STX | 02 |
| o | 6F | > | 3E | SUB | 1A |
| p | 70 | ? | 3F | SYN | 16 |
| | | | | US | 1F |
| | | | | VT | 0B |

7.3.7 Modbus-RTU Protocol

7.3.7.1 Function Code and Protocol

In the following section, station ID is the value set at COM-01 (Int485 St ID), and the starting address is the communication address (starting address size is in bytes). For more information about communication addresses, refer to [7.3.8 Compatible Common Area Parameter](#) on page 358.

Reading up to 8 Consecutive Inverter Parameters Based on the Set Number - Read Holding Register (Func. Code: 0x03) and Read Input Register (Func. Code: 0x04)

Read Holding Registers (Func. Code: 0x03) and Read Input Registers (Func. Code: 0x04) are processed identically by the inverter.

| Codes | Description |
|--------------|--|
| Start Addr. | Starting address 1 of the inverter parameters (common area or keypad) to be read from. |
| No. of Reg. | Number of the inverter parameters (common area or keypad) to be read. |
| Byte Count | Byte number of normal response values based on the number of registers (No. of Reg). |
| Except. Code | Error codes |

Request

| Slave Station ID | Func. Code | Start Addr (Hi) | Start Addr (Lo) | No of Reg (Hi) | No of Reg (Lo) | CRC (Lo) | CRC (Hi) |
|------------------|------------|-----------------|-----------------|----------------|----------------|----------|----------|
| 1 byte | 1 byte | 1 byte | 1 byte | 1 byte | 1 byte | 1 byte | 1 byte |

Normal Response

| Slave Station ID | Func. Code | Byte Count | Value (Hi) | Value (Lo) | ... | Value (Hi) | Value (Lo) | CRC (Lo) | CRC (Hi) |
|------------------|------------|------------|------------|------------|-----|------------|------------|----------|----------|
| 1 byte | 1 byte | 1 byte | 1 byte | 1 byte | ... | 1 byte | 1 byte | 1 byte | 1 byte |

* The number of Value(Hi) and Value(Lo) is changed by the [Request No. of Reg].

Error Response

| Slave Station ID | Func. Code | Except. Code | CRC(Lo) | CRC(Hi) |
|------------------|------------|--------------|---------|---------|
| 1 byte | 1 byte | 1 byte | 1 byte | 1 byte |

* Func. Code of the error response is [Request Func. Code] + 0x80.

Writing One Inverter Parameter Value (Func. Code: 0x06)

| Codes | Description |
|--------------|---|
| Addr. | Address 1 of the inverter parameter (common area or keypad) to be written to. |
| Reg. Value | The inverter parameter (common area or keypad) value to write with. |
| Except. Code | Error codes |

Request

| Slave Station ID | Func.Code | Addr (Hi) | Addr(Lo) | Value(Hi) | Value(Lo) | CRC(Lo) | CRC(Hi) |
|------------------|-----------|-----------|----------|-----------|-----------|---------|---------|
| 1 byte | 1 byte | 1 byte | 1 byte | 1 byte | 1 byte | 1 byte | 1 byte |

Normal Response

| Slave Station ID | Func.Code | Addr (Hi) | Addr(Lo) | Value(Hi) | Value(Lo) | CRC(Lo) | CRC(Hi) |
|------------------|-----------|-----------|----------|-----------|-----------|---------|---------|
| 1 byte | 1 byte | 1 byte | 1 byte | 1 byte | 1 byte | 1 byte | 1 byte |

Error Response

| Slave Station ID | Func. Code | Except. Code | CRC(Lo) | CRC (Hi) |
|------------------|------------|--------------|---------|----------|
| 1 byte | 1 byte | 1 byte | 1 byte | 1 byte |

* Func. Code of the error response is [Request Func. Code] + 0x80.

Writing Multiple Registers (Func. Code: 0x10)

| Codes | Description |
|-------------|---|
| Start Addr. | Starting address 1 of the inverter parameters (common area or keypad) to be written to. |
| No. of Reg. | Number of the inverter parameters (common area or keypad) to be written. |

| Codes | Description |
|--------------|--|
| Reg. Value | The inverter parameter (common area or keypad) values to write with. |
| Except. Code | Error codes |

Request

| Slave Station ID | Func. Code | Start Addr. (Hi) | Start Addr. (Lo) | No of Reg. (Hi) | No of Reg. (Lo) | Byte Count | Reg. Value (Hi) | Reg. Value (Lo) | CRC (Lo) | CRC (Hi) |
|------------------|------------|------------------|------------------|-----------------|-----------------|------------|-----------------|-----------------|----------|----------|
| 1 byte | 1 byte | 1 byte | 1 byte | 1 byte | 1 byte | 1 byte | 1 byte | 1 byte | 1 byte | 1 byte |

Normal Response

| Slave Station ID | Func. Code | Start Addr (Hi) | Start Addr (Lo) | No of Reg. (Hi) | No of Reg. (Lo) | CRC (Lo) | CRC (Hi) |
|------------------|------------|-----------------|-----------------|-----------------|-----------------|----------|----------|
| 1 byte | 1 byte | 1 byte | 1 byte | 1 byte | 1 byte | 1 byte | 1 byte |

Error Response

| Slave Station ID | Func. Code | Except. Code | CRC(Lo) | CRC(Hi) |
|------------------|------------|--------------|---------|---------|
| 1 byte | 1 byte | 1 byte | 1 byte | 1 byte |

* Func. Code of the error response is [Request Func. Code] + 0x80.

Exception Code

| Code |
|--------------------------|
| 01: ILLEGAL FUNCTION |
| 02: ILLEGAL DATA ADDRESS |
| 03: ILLEGAL DATA VALUE |
| 06: SLAVE DEVICE BUSY |
| 14: Write-Protection |

Example of Modbus-RTU Communication In Use

When the Acc time (Communication address 0x1103) is changed to 5.0 sec and the Dec time (Communication address 0x1104) is changed to 10.0 sec.

Frame Transmission from Master to Slave

| Item | Station ID | Function | Starting Address | # of Register | Byte Count | Data 1 | Data 2 | CRC |
|-------------|---------------------|--------------------------|----------------------------|---------------|------------|-----------------------|-------------------------|--------|
| Hex | 0x01 | 0x10 | 0x1102 | 0x0002 | 0x04 | 0x0032 | 0x0064 | 0x1202 |
| Description | COM-01 Int485 St ID | Preset Multiple Register | Start Address-1 (0x1103-1) | - | - | 50 (Acc time 5.0 sec) | 100 (Dec time 10.0 sec) | - |

Frame Transmission from Slave to Master

| Item | Station Id | Function | Starting Address | # of Register | CRC |
|-------------|---------------------|--------------------------|-------------------------------|---------------|--------|
| Hex | 0x01 | 0x10 | 0x1102 | 0x0002 | 0xE534 |
| Description | COM-01 Int485 St ID | Preset Multiple Register | Starting Address-1 (0x1103-1) | - | - |

7.3.8 Compatible Common Area Parameter

The following are common area parameters partly compatible with the iS5, iP5A, iV5, iG5A, S100 series inverters. .(Addresses 0h0000-0h0011 are for compatible common area parameters. Addresses 0h0012-0h001B are for H100 series inverter parameters.)

| Comm. Address | Parameter | Scale | Unit | R/W | Assigned Content by Bit | |
|---------------|----------------------------|----------|------|-----|---|--|
| 0h0000 | Inverter model | - | - | R | F: H100 | |
| 0h0001 | Inverter capacity | - | - | R | 0: 0.75kW, 1: 1.5kW, 2: 2.2kW 3: 3.7kW 4: 5.5kW, 5: 7.5kW 6: 11kW, 7: 15kW, 8: 18.5kW 9: 22kW, 10: 30kW, 11: 37kW 12: 45kW ,13: 55kW, 14: 75kW, 15: 90kW, 16: 110kW, 17: 132kW 18: 160kW, 19: 185kW, 20: 220kW 21: 250kW, 22: 315kW, 23: 355kW 24: 400kW, 25: 500kW | |
| 0h0002 | Inverter input voltage | - | - | R | 0: 220 V product 1: 440 V product | |
| 0h0003 | Version | - | - | R | (Example) 0h0064: Version 1.00 (Example) 0h0065: Version 1.01 | |
| 0h0004 | Reserved | - | - | R | - | |
| 0h0005 | Command frequency | 0.01 | Hz | R/W | - | |
| 0h0006 | Operation command (option) | - | - | R | B15 | Reserved |
| | | | | | B14 | 0: Keypad Freq, |
| | | | | | B13 | 2-8: Terminal block multi-step speed |
| | | | | | B12 | 17: Up, 18: Down |
| | | | | | B11 | 19: STEADY |
| | | | | | B10 | 22: V1, 24: V2, 25: I2, 26: PULSE |
| | | | | | B9 | 27: Built-in 485 28: Communication option 30: JOG, 31: PID |
| | | | | | B8 | 0: Keypad |
| | | | | | B7 | 1: Fx/Rx-1 2: Fx/Rx-2 |
| | | | | B6 | 3: Built-in 485 4: Communication option 5: Time Event | |
| R/W | B5 | Reserved | | | | |

RS-485 Communication Features

| | | | | | | |
|--------|--------------------------------|------|-----|-----|-----|---|
| | | | | | B4 | Emergency stop |
| | | | | | B3 | W: Trip initialization (0→1), R: Trip status |
| | | | | | B2 | Reverse operation (R) |
| | | | | | B1 | Forward operation (F) |
| | | | | | B0 | Stop (S) |
| 0h0007 | Acceleration time | 0.1 | sec | R/W | - | |
| 0h0008 | Deceleration time | 0.1 | sec | R/W | - | |
| 0h0009 | Output current | 0.1 | A | R | - | |
| 0h000A | Output frequency | 0.01 | Hz | R | - | |
| 0h000B | Output voltage | 1 | V | R | - | |
| 0h000C | DC link voltage | 1 | V | R | - | |
| 0h000D | Output power | 0.1 | kW | R | - | |
| 0h000E | Operation status | - | - | R | B15 | 0: HAND, 1: AUTO |
| | | | | | B14 | 1: Frequency command source by communication (built-in, option) |
| | | | | | B13 | 1: Operation command source by communication (built-in, option) |
| | | | | | B12 | Reverse operation command |
| | | | | | B11 | Forward operation command |
| | | | | | B10 | Reserved |
| | | | | | B9 | Jog mode |
| | | | | | B8 | Drive stopping |
| | | | | | B7 | DC Braking |
| | | | | | B6 | Speed reached |
| | | | | | B5 | Decelerating |
| | | | | | B4 | Accelerating |
| | | | | | B3 | Fault Trip - operates according to OUT-30 setting |
| | | | | | B2 | Operating in reverse direction |
| B1 | Operating in forward direction | | | | | |

| | | | | | | |
|--------|-----------------------------|---|---|---|------------|-----------------|
| | | | | | B0 | Stopped |
| 0h000F | Fault trip information | - | - | R | B15 | Reserved |
| | | | | | B14 | Reserved |
| | | | | | B13 | Reserved |
| | | | | | B12 | Reserved |
| | | | | | B11 | Reserved |
| | | | | | B10 | H/W-Diag |
| | | | | | B9 | Reserved |
| | | | | | B8 | Reserved |
| | | | | | B7 | Reserved |
| | | | | | B6 | Reserved |
| | | | | | B5 | Reserved |
| | | | | | B4 | Reserved |
| | | | | | B3 | Level Type trip |
| | | | | | B2 | Reserved |
| B1 | Reserved | | | | | |
| B0 | Latch Type trip | | | | | |
| 0h0010 | Input terminal information | - | - | R | B15 -B7 | Reserved |
| | | | | | B6 | P7 |
| | | | | | B5 | P6 |
| | | | | | B4 | P5 |
| | | | | | B3 | P4 |
| | | | | | B2 | P3 |
| | | | | | B1 | P2 |
| B0 | P1 | | | | | |
| 0h0011 | Output terminal information | - | - | R | B15 | Reserved |
| | | | | | B14 | Reserved |
| | | | | | B13 | Reserved |
| | | | | | B12 | Reserved |
| | | | | | B11 | Reserved |

| | | | | | | |
|-------------------|--|-----|-----|---|--|----------|
| | | | | | B10 | Q1 |
| | | | | | B9 | Reserved |
| | | | | | B8 | Reserved |
| | | | | | B7 | Reserved |
| | | | | | B6 | Reserved |
| | | | | | B5 | Reserved |
| | | | | | B4 | Relay 5 |
| | | | | | B3 | Relay 4 |
| | | | | | B2 | Relay 3 |
| | | | | | B1 | Relay 2 |
| | | | | | B0 | Relay 1 |
| 0h0012 | V1 | 0.1 | % | R | V1 input voltage | |
| 0h0013 | Thermal | 0.1 | % | R | Input Thermal | |
| 0h0014 | V2 | 0.1 | % | R | V2 input voltage | |
| 0h0015 | I2 | 0.1 | % | R | I2 input Current | |
| 0h0016 | Motor rotation speed | 1 | Rpm | R | Displays existing motor rotation speed | |
| 0h0017 -0h0019 | Reserved | - | - | - | - | |
| 0h001A | Select Hz/rpm | - | - | R | 0: Hz unit, 1: rpm unit | |
| 0h001B | Display the number of poles for the selected motor | - | - | R | Display the number of poles for the selected motor | |

7.3.9 H100 Expansion Common Area Parameter

7.3.9.1 Monitoring Area Parameter (Read Only)

| Comm. Address | Parameter | Scale | Unit | Assigned content by bit |
|---------------|---|-------|------|--|
| 0h0300 | Inverter model | - | - | H100: 000Fh |
| 0h0301 | Inverter capacity | - | - | 0.75 kW: 4008h, 1.5 kW: 4015h 2.2 kW: 4022h, 3.7 kW: 4037h 5.5 kW: 4055h, 7.5 kW: 4075h 11 kW: 40B0h, 15 kW: 40F0h 18.5 kW: 4125h, 22 kW: 4160h 30 kW: 41E0h, 37 kW: 4250h, 45 kW: 42D0h, 55 kW: 4370h, 75 kW: 44B0h, 90 kW: 45A0h, 110 kW: 46E0h, 132 kW: 4840h 160 kW: 4A00h, 185kW: 4B90h, 220 kW: 4DC0h, 250 kW: 4FA0h, 315 kW: 53B0h, 355 kW: 5630h, 400 kW: 5900h, 500 kW: 5F40h |
| 0h0302 | Inverter input voltage/power (Single phase, 3-phase)/cooling method | - | - | 200 V 3-phase forced cooling: 0231h |
| | | | | 400 V 3-phase forced cooling: 0431h |
| 0h0303 | Inverter S/W version | - | - | (ex) 0h0064: Version 1.00 |
| | | | | 0h0065: Version 1.01 |
| 0h0304 | Reserved | - | - | - |
| 0h0305 | Inverter operation state | - | - | B15 |
| | | | | B14 |
| | | | | B13 |
| | | | | B12 |
| | | | | B11- |
| | | | | B8 |
| | | | | B7 |
| | | | | B6 |
| | | | | B5 |
| | | | | 0: Normal state 4: Warning occurred 8: Fault occurred |
| | | | | - |
| | | | | 1: Speed searching 2: Accelerating 3: Operating at constant rate 4: Decelerating 5: Decelerating to stop |

| | | | | | |
|--------------|---|------|----|--|--|
| | | | | B4 | 6: HW OCS 7: SW OCS 8: Dwell operating |
| | | | | B3 | 0: Stopped 1: Operating in forward direction 2: Operating in reverse direction 3: DC operating |
| | | | | B2 | |
| | | | | B1 | |
| | | | | B0 | |
| 0h0306 | Inverter operation frequency command source | - | - | B15 | Operation command source 0: Keypad 1: Communication option 3: Built-in RS 485 4: Terminal block |
| | | | | B14 | |
| | | | | B13 | |
| | | | | B12 | |
| | | | | B11 | |
| | | | | B10 | |
| | | | | B9 | |
| | | | | B8 | |
| | | | | B7 | Frequency command source 0: Keypad speed 1: Keypad torque 2-4: Up/Down operation speed 5: V1, 7: V2, 8: I2 9: Pulse 10: Built-in RS 485 11: Communication option 13: Jog 14: PID 25-31: Multi-step speed frequency |
| | | | | B6 | |
| | | | | B5 | |
| | | | | B4 | |
| | | | | B3 | |
| | | | | B2 | |
| B1 | | | | | |
| B0 | | | | | |
| 0h0307 | Keypad S/W version | - | - | (Ex.) 0h0064: Version 1.00 | |
| 0h0308 | Keypad title version | - | - | (Ex.) 0h0065: Version 1.01 | |
| 0h0309 | IO Board Version | - | - | (Ex.) 0h0064: Version 1.00 (Ex.) 0h0065: Version 1.01 | |
| 0h030A–0h30F | Reserved | - | - | - | |
| 0h0310 | Output current | 0.1 | A | - | |
| 0h0311 | Output frequency | 0.01 | Hz | - | |

| | | | | | |
|-------------------|---|-----|-----|---|----------------|
| 0h0312 | Output rpm | 0 | Rpm | - | |
| 0h0313 | Reserved | - | - | - | |
| 0h0314 | Output voltage | 1 | V | - | |
| 0h0315 | DC Link voltage | 1 | V | - | |
| 0h0316 | Output power | 0.1 | kW | - | |
| 0h0317 | Reserved | - | - | - | |
| 0h0318 | PID reference | 0.1 | % | PID reference value | |
| 0h0319 | PID feedback | 0.1 | % | PID feedback value | |
| 0h031A | Display the number of poles for the 1 st motor | - | - | Displays the number of poles for the first motor | |
| 0h031B | Display the number of poles for the 2 nd motor | - | - | Displays the number of poles for the 2nd motor | |
| 0h031C | Display the number of poles for the selected motor | - | - | Displays the number of poles for the selected motor | |
| 0h031D | Select Hz/rpm | - | - | 0: Hz, 1: rpm | |
| 0h031E -0h031F | Reserved | - | - | - | |
| 0h0320 | Digital input information | | | B15-B7 | Reserved |
| | | | | B6 | P7 (I/O board) |
| | | | | B5 | P6 (I/O board) |
| | | | | B4 | P5 (I/O board) |
| | | | | B3 | P4 (I/O board) |
| | | | | B2 | P3 (I/O board) |
| | | | | B1 | P2 (I/O board) |
| | | | | B0 | P1 (I/O board) |
| 0h0321 | Digital output information | | | B15-B11 | Reserved |
| | | | | B10 | Q1 |
| | | | | B9-B5 | Reserved |
| | | | | B4 | Relay 5 |
| | | | | B3 | Relay 4 |

RS-485 Communication Features

| | | | | | |
|--------|-----------------------------------|------|-----|--|-----------------------|
| | | | | B2 | Relay 3 |
| | | | | B1 | Relay 2 |
| | | | | B0 | Relay 1 |
| 0h0322 | Virtual digital input information | - | - | B15–B8 | Reserved |
| | | | | B7 | Virtual DI 8 (COM-77) |
| | | | | B6 | Virtual DI 7 (COM-76) |
| | | | | B5 | Virtual DI 6 (COM-75) |
| | | | | B4 | Virtual DI 5 (COM-74) |
| | | | | B3 | Virtual DI 4 (COM-73) |
| | | | | B2 | Virtual DI 3 (COM-72) |
| | | | | B1 | Virtual DI 2 (COM-71) |
| | | | | B0 | Virtual DI 1 (COM-70) |
| 0h0323 | Display the selected motor | - | - | 0: 1st motor/1: 2nd motor | |
| 0h0324 | AI1 | 0.01 | % | Analog input V1 or Thermal (I/O board) | |
| 0h0325 | AI2 | 0.01 | % | Analog input V2 or I2 (I/O board) | |
| 0h0326 | Reserved | - | - | Reserved | |
| 0h0327 | Reserved | - | - | Reserved | |
| 0h0328 | AO1 | 0.01 | % | Analog output 1 (I/O board) | |
| 0h0329 | AO2 | 0.01 | % | Analog output 2 (I/O board) | |
| 0h032A | Reserved | 0.01 | % | Reserved | |
| 0h032B | Reserved | 0.01 | % | Reserved | |
| 0h032C | Reserved | - | - | Reserved | |
| 0h032D | Reserved | - | - | Reserved | |
| 0h032E | Consumption energy (kWh) | 0.1 | kWh | Consumption energy (kWh) | |
| 0h032F | Consumption energy (MWh) | 1 | MWh | Consumption energy (MWh) | |
| 0h0330 | Latch type trip information - 1 | - | - | B15 | PC Repeat Err |
| | | | | B14 | Over Heat Trip |
| | | | | B13 | Reserved |

| | | | | | |
|--------|---------------------------------|---|---|--------|----------------|
| | | | | B12 | External Trip |
| | | | | B11 | Damper Err |
| | | | | B10 | Pipe Break |
| | | | | B9 | NTC Open |
| | | | | B8 | Reserved |
| | | | | B7 | Reserved |
| | | | | B6 | In Phase Open |
| | | | | B5 | Out Phase Open |
| | | | | B4 | Low Voltage2 |
| | | | | B3 | E-Thermal |
| | | | | B2 | Inverter OLT |
| | | | | B1 | Under Load |
| | | | | B0 | Over Load |
| 0h0331 | Latch type trip information - 2 | - | - | B15 | Reserved |
| | | | | B14 | MMC Interlock |
| | | | | B13 | Reserved |
| | | | | B12 | Reserved |
| | | | | B11 | Reserved |
| | | | | B10 | Option Trip-1 |
| | | | | B9 | No Motor Trip |
| | | | | B8 | Reserved |
| | | | | B7 | IO Board Trip |
| | | | | B6 | Broken Belt |
| | | | | B5 | ParaWrite Trip |
| | | | | B4 | TB Trip |
| | | | | B3 | Fan Trip |
| | | | | B2 | Thermal Trip |
| B1 | Level Detect | | | | |
| B0 | Reserved | | | | |
| 0h0332 | Level type trip information | - | - | B15–B4 | Reserved |

RS-485 Communication Features

| | | | | | |
|--------|--------------------------------|---|---|------------|-------------------|
| | | | | B3 | Lost Keypad |
| | | | | B2 | Lost Command |
| | | | | B1 | Low Voltage |
| | | | | B0 | BX |
| 0h0333 | H/W Diagnosis Trip information | - | - | B15– B3 | Reserved |
| | | | | B2 | Watchdog-1 error |
| | | | | B1 | EEP Err |
| | | | | B0 | ADC Offset |
| 0h0334 | Warning information-1 | - | - | B15 | Broken Belt |
| | | | | B14 | Low Battery |
| | | | | B13 | Load Tune |
| | | | | B12 | Fan Exchange |
| | | | | B11 | CAP. Warning |
| | | | | B10 | Level Detect |
| | | | | B9 | Reserved |
| | | | | B8 | Lost Keypad |
| | | | | B7 | Pipe Break |
| | | | | B6 | Fire Mode |
| | | | | B5 | DB Warn %ED |
| | | | | B4 | Fan Warning |
| | | | | B3 | Lost Command |
| | | | | B2 | Inv Over Load |
| B1 | Under Load | | | | |
| B0 | Over Load | | | | |
| 0h0335 | Latch type trip information -3 | - | - | B15 | Reserved |
| | | | | – | Reserved |
| | | | | B4 | Reserved |
| | | | | B3 | Overcurrent2 Trip |

| | | | | | |
|-------------------|------------------------|-----------|-----------|---|-------------------|
| | | | | B2 | Overvoltage Trip |
| | | | | B1 | Overcurrent1 Trip |
| | | | | B0 | Ground Fault Trip |
| 0h0336 | Warning information-2 | - | - | B15 | Reserved |
| | | | | ~ | Reserved |
| | | | | B3 | KPD H.O.A Lock |
| | | | | B2 | Lsig Tune Err |
| | | | | B1 | Rs Tune Err |
| | | | | B0 | ParaWrite Fail |
| 0h0337– 0h0339 | Reserved | - | - | Reserved | |
| 0h033A | Proc PID Output | 0.01 | % | Process PID Output (%) | |
| 0h033B | Proc PID UnitScale Ref | Proc Unit | Proc Unit | Unit Scaled Process PID reference value | |
| 0h033C | Proc PID UnitScale Fdb | Proc Unit | Proc Unit | Unit Scaled Process PID feedback value | |
| 0h0340 | On Time date | 0 | Day | Total number of days the inverter has been powered on | |
| 0h0341 | On Time Minute | 0 | Min | Total number of minutes excluding the total number of On Time days | |
| 0h0342 | Run Time date | 0 | Day | Total number of days the inverter has driven the motor | |
| 0h0343 | Run Time minute | 0 | Min | Total number of minutes excluding the total number of Run Time days | |
| 0h0344 | Fan Time date | 0 | Day | Total number of days the heat sink fan has been running | |
| 0h0345 | Fan Time minute | 0 | Min | Total number of minutes excluding the total number of Fan Time days | |
| 0h0346 –0h0348 | Reserved | - | - | Reserved | |

RS-485 Communication Features

| | | | | | |
|-------------------|------------------------|-----------|-----------|-------------------------------------|------------|
| 0h0349 | Reserved | - | - | - | |
| 0h034A | Option 1 | - | - | 0: None, 5: LonWorks | |
| 0h034B | Reserved | - | - | Reserved | |
| 0h034C | Reserved | | | Reserved | |
| 0h034D– 0h034F | Reserved | - | - | Reserved | |
| 0h0350 | E-PID 1 Output | 0.01 | % | External PID 1 output | |
| 0h0351 | E-PID 1 Ref | 0.1 | % | External PID 1 Reference | |
| 0h0352 | E-PID 1 Fdb | 0.1 | % | External PID 1 feedback | |
| 0h0353 | E-PID 1 Unit Scale Ref | Proc Unit | Proc Unit | Unit Scale External PID 1 Reference | |
| 0h0354 | E-PID 1 Unit Scale Fdb | Proc Unit | Proc Unit | Unit Scale External PID 1 feedback | |
| 0h0355 | Reserved | - | - | Reserved | |
| 0h0356 | Reserved | - | - | Reserved | |
| 0h0357 | E-PID 2 Output | 0.01 | % | External PID 2 output | |
| 0h0358 | E-PID 2 Ref | 0.1 | % | External PID 2 Reference | |
| 0h0359 | E-PID 2 Fdb | 0.1 | % | External PID 2 feedback | |
| 0h035A | E-PID 2 Unit Scale Ref | Proc Unit | Proc Unit | Unit Scale External PID 2 Reference | |
| 0h035B | E-PID 2 Unit Scale Fdb | Proc Unit | Proc Unit | Unit Scale External PID 2 feedback | |
| 0h035C | Application Status | - | - | B15–B2 | Reserved |
| | | | | B1 | Fire Mode |
| | | | | B0 | Pump Clean |
| 0h035D | Inv Temperature | 0 | °C | Heatsink Temperature | |

| | | | | | |
|--------|-------------------------------------|-----|---|-------------------------|-------------------------------|
| 0h035E | Power Factor | 0.1 | - | Output power factor | |
| 0h035F | Inv Fan Time | - | % | INV Fan running time(%) | |
| 0h0360 | Multi motor control terminal output | - | - | B15 | Reserved |
| | | | | - | Reserved |
| | | | | B5 | Reserved |
| | | | | B4 | 5 th motor running |
| | | | | B3 | 4 th motor running |
| | | | | B2 | 3 rd motor running |
| | | | | B1 | 2 nd motor running |
| | | | | B0 | 1 st motor running |



7.3.9.2 Control Area Parameter (Read/Write)

| Comm. Address | Parameter | Scale | Unit | Assigned Content by Bit | |
|---------------|---|-------|------|--|--|
| 0h0380 | Frequency command | 0.01 | Hz | Command frequency setting | |
| 0h0381 | RPM command | 1 | Rpm | Command rpm setting | |
| 0h0382 | Operation command | - | - | B15–B4 | Reserved |
| | | | | B3 | 0 → 1: Free-run stop |
| | | | | B2 | 0 → 1: Trip initialization |
| | | | | B1 | 0: Reverse command, 1: Forward command |
| | | | | B0 | 0: Stop command, 1: Run command |
| | | | | Example: Forward operation command 0003h, Reverse operation command 0001h | |
| 0h0383 | Acceleration time | 0.1 | sec | Acceleration time setting | |
| 0h0384 | Deceleration time | 0.1 | sec | Deceleration time setting | |
| 0h0385 | Virtual digital input control (0: Off, 1: On) | - | - | B15–B8 | Reserved |
| | | | | B7 | Virtual DI 8 (COM-77) |
| | | | | B6 | Virtual DI 7 (COM-76) |
| | | | | B5 | Virtual DI 6 (COM-75) |
| | | | | B4 | Virtual DI 5 (COM-74) |
| | | | | B3 | Virtual DI 4 (COM-73) |
| | | | | B2 | Virtual DI 3 (COM-72) |
| | | | | B1 | Virtual DI 2 (COM-71) |
| | | | | B0 | Virtual DI 1 (COM-70) |
| 0h0386 | Digital output control (0: Off, 1: On) | - | - | B15–B11 | Reserved |
| | | | | B10 | Q1 |
| | | | | B9–B5 | Reserved |
| | | | | B4 | Relay 5 |
| | | | | B3 | Relay 4 |
| | | | | B2 | Relay 3 |

| | | | | B1 | Relay 2 |
|-------------------|---------------------------|-----------|-----------|---|---------|
| | | | | B0 | Relay 1 |
| 0h0387 | KPD H.O.A Lock | 1 | - | 0 : Locked, 1 : During Run, 2 : Unlocked | |
| 0h0388 | PID reference | 0.1 | % | Process PID reference | |
| 0h0389 | PID feedback value | 0.1 | % | Process PID feedback | |
| 0h038A | Motor rated current | 0.1 | A | - | |
| 0h038B | Motor rated voltage | 1 | V | - | |
| 0h038C– 0h038D | Reserved | - | - | Reserved | |
| 0h038E | Proc PID Unit Reference | Proc Unit | Proc Unit | Unit Scale Process PID reference | |
| 0h038F | Proc PID Unit Feedback | Proc Unit | Proc Unit | Unit Scale Process PID feedback | |
| 0h0390– 0h0399 | Reserved | - | - | Reserved | |
| 0h039A | Anytime Para | - | - | Set the CNF-20 value (refer to 5.49 Operation State Monitor on page 302) | |
| 0h039B | Monitor Line-1 | - | - | Set the CNF-21 value (refer to 5.49 Operation State Monitor on page 302) | |
| 0h039C | Monitor Line-2 | - | - | Set the CNF-22 value (refer to 5.49 Operation State Monitor on page 302) | |
| 0h039D | Monitor Line-3 | - | - | Set the CNF-23 value (refer to 5.49 Operation State Monitor on page 302) | |
| 0h039E– 0h039F | Reserved | | | Reserved | |
| 0h03A0 | PID Ref 1 Aux Value | 0.1 | % | PID Aux 1 reference | |
| 0h03A1 | PID Ref 2 Aux Value | 0.1 | % | PID Aux 2 reference | |
| 0h03A2 | PID Feedback Aux Value | 0.1 | % | PID Aux feedback | |
| 0h03A3 | Proc PID Aux 1 Unit Scale | Proc Unit | Proc Unit | Unit Scale PID Aux 1 reference | |
| 0h03A4 | Proc PID Aux 2 Unit Scale | Proc Unit | Proc Unit | Unit Scale PID Aux 2 reference | |

| | | | | |
|---------------|-----------------------------|-----------|-----------|-------------------------------------|
| 0h03A5 | Proc PID Fdb Aux Unit Scale | Proc Unit | Proc Unit | Unit Scale PID Aux feedback |
| 0h03A6–0h03AF | Reserved | | | Reserved |
| 0h03B0 | E-PID 1 Ref | 0.1 | % | External PID 1 reference |
| 0h03B1 | E-PID 1 Fdb | 0.1 | % | External PID 1 reference |
| 0h03B2 | E-PID 1 Unit Scale Ref | Proc Unit | Proc Unit | Unit Scale External PID 1 reference |
| 0h03B3 | E-PID 1 Unit Scale Fdb | Proc Unit | Proc Unit | Unit Scale External PID 1 feedback |
| 0h03B4 | Reserved | | | Reserved |
| 0h03B5 | E-PID 2 Ref | 0.1 | % | External PID 2 reference |
| 0h03B6 | E-PID 2 Fdb | 0.1 | % | External PID 2 feedback |
| 0h03B7 | E-PID 2 Unit Scale Ref | Proc Unit | Proc Unit | Unit Scale External PID 2 reference |
| 0h03B8 | E-PID 2 Unit Scale Fdb | Proc Unit | Proc Unit | Unit Scale External PID 2 feedback |

Note

A frequency set via communication using the common area frequency address (0h0380, 0h0005) is not saved even when used with the parameter save function. To save a changed frequency to use after a power cycle, follow these steps:

- 1 Set DRV-07 to 'Keypad-1' and select a target frequency.
- 2 Set the frequency via communication into the parameter area frequency address (0h1101).
- 3 Perform the parameter save (0h03E0: '1') before turning off the power. After the power cycle, the frequency set before turning off the power is displayed.

7.3.9.3 Inverter Memory Control Area Parameter (Read and Write)

| Comm. Address | Parameter | Scale | Unit | Changeable During Running | Function |
|---------------|---|-------|------|---------------------------|---|
| 0h03E0 | Save parameters | - | - | X | 0: No, 1: Yes |
| 0h03E1 | Monitor mode initialization | - | - | O | 0: No, 1: Yes |
| 0h03E2 | Parameter initialization | - | - | X | 0: No, 1: All Grp 2: DRV Grp 3: BAS Grp 4: ADV Grp 5: CON Grp 6: IN Grp 7: OUT Grp 8: COM Grp 9: PID Grp 10: EPID Grp 11: AP1 Grp 12: AP2 Grp 13: AP3 Grp 14: PRT Grp 15: M2 Grp Setting is prohibited during fault trip interruptions. |
| 0h03E3 | Display changed | - | - | O | 0: No, 1: Yes |
| 0h03E4 | Macro Function Setting | - | - | X | 0: Basic 1: Compressor 2: Supply Fan 3: Exhaust Fan 4: Cooling Tower 5: Circul. Pump 6: Vacuum Pump 7: Constant Torq |
| 0h03E5 | Delete all fault history | - | - | O | 0: No, 1: Yes |
| 0h03E6 | Delete user-registered codes | - | - | O | 0: No, 1: Yes |
| 0h03E7 | Hide parameter mode | 0 | Hex | O | Write: 0–9999 Read: 0: Unlock, 1: Lock |
| 0h03E8 | Lock parameter mode | 0 | Hex | O | Write: 0–9999 Read: 0: Unlock, 1: Lock |
| 0h03E9 | Easy start on (easy parameter setup mode) | - | - | O | 0: No, 1: Yes |
| 0h03EA | Initializing power consumption | - | - | O | 0: No, 1: Yes |
| 0h03EB | Initialize inverter operation accumulative time | - | - | O | 0: No, 1: Yes |

| | | | | | |
|--------|---|---|---|---|---------------|
| 0h03EC | Initialize cooling fan accumulated operation time | - | - | 0 | 0: No, 1: Yes |
|--------|---|---|---|---|---------------|

Note

- When setting parameters in the inverter memory control area, the values are reflected to the inverter operation and saved. Parameters set in other areas via communication are reflected to the inverter operation, but are not saved. All set values are cleared following an inverter power cycle and revert back to its previous values. When setting parameters via communication, ensure that a parameter save is completed prior to shutting the inverter down.
- Set parameters very carefully. After setting a parameter to '0' via communication, set it to another value. If a parameter has been set to a value other than '0' and a non-zero value is entered again, an error message is returned. The previously-set value can be identified by reading the parameter when operating the inverter via communication.
- The addresses 0h03E7 and 0h03E8 are parameters for entering the password. When the password is entered, the condition will change from Lock to Unlock, and vice versa. When the same parameter value is entered continuously, the parameter is executed just once. Therefore, if the same value is entered again, change it to another value first and then re-enter the previous value. For example, if you want to enter 244 twice, enter it in the following order: 244 → 0 → 244.
- If the communication parameter settings are initialized by setting the address 0h03E2 to [1: All Grp] or [8: COM Grp], or if any Macro function item is modified by setting the address 0h03E4, all the communication parameter settings are reverted to the factory default. If this happens, the inverter may not be able to properly receive responses from the upper-level devices due to the changes in the settings.
- If there is an undefined address in the addresses for reading multiple consecutive data defined in the common area, the undefined address returns 0xFFFF while all the others return normal response. If all the consecutive addresses are undefined, one return code is received from the first undefined address only.
- If there is an undefined address in the addresses for writing into multiple consecutive data defined in the common area, or if the value that is being written is not a valid one, no error response about the writing operation is returned. If all the consecutive addresses are undefined, or if all the data is invalid, one return code is received from the first undefined address only.

⚠ Caution

It may take longer to set the parameter values in the inverter memory control area because all data is saved to the inverter. Be careful as communication may be lost during parameter setup if parameter setup is continues for an extended period of time.

7.4 BACnet Communication

7.4.1 What is BACnet Communication?

BACnet (Building Automation and Control network) is a communication network frequently used in building automation. BACnet introduces the concept of object-oriented systems, and defines standardized objects. By exchanging data, this function makes communication possible between products from different companies. It also standardizes some of the general services carried out by using these standard objects.

7.4.2 BACnet Communication Standards

| Application | Items | Specification |
|---------------|-------------------|--|
| Connection | Interface | 5 Pin Pluggable connector |
| | Data transmission | RS-485 MS/TP, Half-duplex |
| | Cable | Twisted pair (1 pair and shield) |
| Communication | BACnet MS/TP | Stated in ANSI/ASHRAE Standards 135-2004 |
| | Baud Rate | Supports 9600, 19200, 38400, 76800 bps |
| | MAC Address | 1–127 |
| | Start/Stop bit | Start 1 bit, Stop ½ bit |
| | Parity check | None/Even/Odd |

7.4.3 BACnet Quick Communication Start

Follow the instructions below to configure the BACnet network for a quick start.

- 1 Set five multi-function input terminals (IN-65–71 PxDefine) to 'Interlock 1' – 'Interlock 5' respectively, in the correct motor order.

Note

- When auto change mode selection (AP1–55) is set to '0 (None)' or '1 (Aux)', and if 5 motors are operated, including the main motor, the interlock numbers 1,2,3,4,5 refer to the monitors connected to Relay 1,2,3,4,5 (If interlock numbers 1,2,3,4,5 are connected to Relay 1,2,3,4,5 at the inverter output terminal).
- If auto change mode selection (AP1-55) is set to '2 (Main)', and the main and

auxiliary motors are connected to the inverter output terminal Relay 1,2,3,4, Interlock 1,2,3,4 are the monitors connected to Relay 1,2,3,4. Set COM-04 Int485 Mode.

- 2 Set the Device Object Instances for COM-21 and 22 and define the values. The device object instances must have unique values.
- 3 Set COM-01 (Int485 St ID) by entering a value (for BACnet, the Int485 station ID must be set within a range of 0–127). The station ID value set at COM-01 must be within the value range defined by the Max Master Property of different Master for MS/TP token passing.
- 4 Test the network and make sure the BACnet communication is working properly.

| Group | Code | Name | LCD display | Parameter Setting | Setting Range | Unit | |
|-------|------------------------|----------------------------------|----------------|-------------------|---------------|-------------------------|--|
| COM | 03 | Communication Speed | Baudrate | 9600 bps | 0 | 1200 ¹⁾ | |
| | | | | | 1 | 2400 ¹⁾ | |
| | | | | | 2 | 4800 ¹⁾ | |
| | | | | | 3 | 9600 | |
| | | | | | 4 | 19200 | |
| | | | | | 5 | 38400 | |
| | | | | | 6 | 56Kbps ¹⁾ | |
| | | | | | 7 | 76.8Kbps | |
| | | | | | 8 | 115.2Kbps ¹⁾ | |
| | 04 | Communication Mode | Int485 Mode | D8/PN/S1 | 0 | D8/PN/S1 | |
| | | | | | 1 | D8/PN/S2 | |
| | | | | | 2 | D8/PE/S1 | |
| | | | | | 3 | D8/PO/S1 | |
| | 20 | Maximum number of BACnet Masters | BAC Max Master | 127 | 1–127 | - | |
| 21 | BACnet device number 1 | BAC Dev Inst1 | 237 | 0–4194 | - | | |
| 22 | BACnet device number 2 | BAC Dev Inst2 | 0 | 0–999 | - | | |
| 23 | BACnet device password | BAC PassWord | 0 | 0–32767 | - | | |

1) 1200 bps, 2400 bps, 4800 bps, 56Kbps, 115.2Kbps cannot be set in communication speed setting in case of BACnet communication.

BACnet Parameter Setting Details

| Code | Description |
|------------------------------------|--|
| COM-01 Int485 ST ID (MAC ID) | Refers to MACID setting parameter used in BACnet. All MACIDs of the inverter using BACnet must be set before connecting to BUS. MACID must have the unique value from the Network to be connected to MACID. If BACnet is used, the value must be within 0–127. Communication is not available if the value is not included in the range. |
| COM-03 Baud Rate | Sets the communication speed to use in the network. |
| COM-20 BAC Mas Master | Range for Max Master that is the number of devices currently connected to the communication Line is 1–127, and the default value is 127. |
| COM-21–22 BAC Dev Inst 1–2 | BACnet Device Instance is used to identify BACnet Device, and must be set as the unique value in the BACnet network. It is used efficiently when finding BACnet Device of other Devices while installing. The following formula is used to calculate the Device Instance value: (COM-21 X 1000) + COM-22 Therefore, in the Device Instance value, COM-21 takes the thousands and higher places (fourth digit and over) and COM-22 takes the hundreds and lower places (third digit and below). COM-21 and COM-22 have the ranges of 0–4194 and 0–999 respectively, because Device Instance can have the value within 0–4,194,302. |
| COM-23 BAC Password | Refers to the password used for Warm/Cold Start. COM-23 Password parameter can be set within 0–32767, and the default value is 0. If the parameter setting range is set to 1–32768, the Password value set at BACnet Master and the value set at COM-23 must be the same to operate Warm/Cold Start. If COM-23 Password is set to '0', the password of BACnet Master is ignored and Warm/Cold Start is operated. |

Note

MaxMaster and MACID affect performing Network communication. It is recommended to set as small value as possible, and to set the continuous value for MACID. If the values are set as explained above, efficient Token Passing Configuration is possible because each Master tries to give Token to Device set as its own (MACD+1).

7.4.4 Protocol Implementation

The following table sums the information required to implement a BACnet system. Refer to each section of the table to implement a BACnet system properly.

| Category | Items | Remarks |
|---|---|--|
| BACnet Services | I-Am (Answer to Who-Is, when broadcast or reset after power-up) | |
| | I-Have (Answer to Who-Has) | |
| | Read Property | |
| | Write Property | |
| | Device Communication Control | Ignores Password in Device Communication Control |
| | Reinitialize Device | Warm/Cold Starts (Supports Password) Start Backup, End Backup, Start Restore, End Restore, or Abort Restore services are NOT available. |
| Data Link Layer | BACnet communication card supports an MS/TP Master Data Link Layer | Supported Standards: MS/TP Available speed: 9600, 19200, 38400, and 76800 bps |
| MAC ID/Device Object Instance configuration | Set at COM-01 Int485 ST ID (MAC ID). The Device Object Instances are set at COM-21 and COM-22. | |
| MAX Master Property | Set at COM-20 (MAX Master Value). | |

7.4.5 Object Map

| Property | Object Type | | | | | | |
|-------------------|-------------|----|----|----|----|-----|-----|
| | Device | BI | BV | AI | AO | MSI | MVI |
| Object Identifier | ○ | ○ | ○ | ○ | ○ | ○ | ○ |
| Object Name | ○ | ○ | ○ | ○ | ○ | ○ | ○ |
| Object Type | ○ | ○ | ○ | ○ | ○ | ○ | ○ |
| System Status | ○ | | | | | | |
| Vendor Name | ○ | | | | | | |
| Vendor Identifier | ○ | | | | | | |
| Model Name | ○ | | | | | | |

| Property | Object Type | | | | | | |
|------------------------|-------------|----|----|----|----|-----|-----|
| | Device | BI | BV | AI | AO | MSI | MVI |
| Firmware Revision | O | | | | | | |
| Appl Software Revision | O | | | | | | |
| Location | O | | | | | | |
| Protocol Version | O | | | | | | |
| Protocol Revision | O | | | | | | |
| Services Supported | O | | | | | | |
| Object Types Supported | O | | | | | | |
| Object List | O | | | | | | |
| Max APDU Length | O | | | | | | |
| APDU Timeout | O | | | | | | |
| Number APDU Retries | O | | | | | | |
| Max Master | O | | | | | | |
| Max Info Frames | O | | | | | | |
| Device Address Binding | O | | | | | | |
| Database Revision | O | | | | | | |
| Preset Value | | O | O | O | O | O | O |
| Description | O | O | O | O | O | O | O |
| Status Flags | | O | O | O | O | O | O |
| Event State | | O | O | O | O | O | O |
| Reliability | | O | O | O | O | O | O |
| Out-of-Service | | O | O | O | O | O | O |
| Number of states | | | | | | O | O |
| State text | | | | | | O | O |
| Units | | | | O | O | | |
| Polarity | | O | | | | | |
| Active Text | | O | O | | | | |
| Inactive Text | | O | O | | | | |

* **BI**–Binary Input / **BV**–Binary Value / **AI**–Analog Input / **AV**–Analog Value / **MSI**–Multistate Input / **MSV**–Multistate Value

You can read/write in Location and Description only if it is the device object. You can write a maximum of 29 words.

7.4.5.1 Analog Value Object Instance

| Instance ID | Object Name | Description | Setting Range | Units | R/W |
|-------------|-----------------|-----------------------------|---------------|-------|-----|
| AV1 | CommTimeoutSet | Command timeout setting | 0.1–120.0 | Secs | R/W |
| AV2 | AccelTimeSet | Accelerate time setting | 0.0–600.0 | Secs | R/W |
| AV3 | DecelTimeSet | Decelerate time setting | 0.0–600.0 | Secs | R/W |
| AV4 | CommandFreqSet | Command frequency setting** | 0.00–DRV-20 | Hz | R/W |
| AV5 | PIDReferenceSet | PID reference setting | 0–100.0 | % | R/W |
| AV6 | PIDFeedbackSet | PID feedback setting | 0–100.0 | % | R/W |

⚠ Caution

- When PowerOn Resume (COM-96) is set to 'yes', value is saved even if the power of the inverter is disconnected. When PowerOn Resume (COM-96) is set to 'no', value is not saved if the power of the inverter is disconnected.
- A value higher than the maximum frequency (DRV-20) cannot be used. The maximum frequency can be set by using the keypad. This value can be used when Freq Ref Src (DRV-07) is set to 'Int 485'.
- AV2, AV3 and AV4 are used to provide acceleration/deceleration rate and frequency reference commands. These can be written in AUTO mode only.

7.4.5.2 Multi-state Value Object Instance

| Instance ID | Object Name | Description | Setting Range | Units | R/W |
|-------------|-------------|--------------------------------|--|-------|-----|
| MSV1 | LostCommand | Command lost operation setting | 0: None 1: FreeRun 2: Dec 3: HoldInput 4: HoldOutput | MSG | R/W |

| Instance ID | Object Name | Description | Setting Range | Units | R/W |
|-------------|-------------|-------------|---------------|-------|-----|
| | | | 5: LostPreset | | |

7.4.5.3 Binary Value Object Instance

| Instance ID | Object Name | Description | Active /Inactive Text | R/W |
|-------------|----------------|------------------------|-----------------------|-----|
| BV1 | StopCmd | Stop command | False/True | R/W |
| BV2 | RunForwardCmd | Run forward command | False/True | R/W |
| BV3 | RunReverseCmd | Run reverse command | False/True | R/W |
| BV4 | ResetFaultCmd | Fault reset command | False/True | R/W |
| BV5 | FreeRunStopCmd | Free run stop command | False/True | R/W |
| BV6 | Relay1Cmd | Relay 1 On/Off command | False/True | R/W |
| BV7 | Relay2Cmd | Relay 2 On/Off command | False/True | R/W |
| BV8 | Relay3Cmd | Relay 3 On/Off command | False/True | R/W |
| BV9 | Relay4Cmd | Relay 4 On/Off command | False/True | R/W |
| BV10 | Relay5Cmd | Relay 5 On/Off command | False/True | R/W |
| BV11 | Q1Cmd | Q 1 On/Off command | False/True | R/W |

7.4.5.4 Analog Input Object Instance

| Instance ID | Object Name | Description | Units | R/W |
|-------------|-----------------|-----------------------|-------|-----|
| AI1 | InvCap (kW) | Inverter capacity | kW | R |
| AI2 | InvCap (HP) | Inverter capacity | HP | R |
| AI3 | InvVoltageClass | Inverter voltage type | Volts | R |

| Instance ID | Object Name | Description | Units | R/W |
|-------------|----------------|--|-------|-----|
| AI4 | OutputCurrent | Output current | Amps | R |
| AI5 | OutputFreq | Output frequency | Hz | R |
| AI6 | OutputVolgate | Output voltage | Volts | R |
| AI7 | DCLinkVoltage | DC Link voltage | Volts | R |
| AI8 | OutputPower | Output power | kW | R |
| AI9 | AI1 | Value of Analog 1 | % | R |
| AI10 | AI2 | Values of Analog 2 | % | R |
| AI11 | OutputRPM | Output speed | RPM | R |
| AI12 | Pole | Pole number of the motor | - | R |
| AI13 | InvStatus | Information of the inverter state (Refer to address 0h0305 in the common area) ^(Note1) | - | R |
| AI14 | LatchTripInfo1 | Latch type trip information1 (Refer to address 0h0330 in the common area) ^(Note1) | - | R |
| AI15 | LatchTripInfo2 | Latch type trip information2 (Refer to address 0h0331 in the common area) ^(Note1) | - | R |
| AI16 | LatchTripInfo3 | Latch type trip information3 (Refer to address 0h0335 in the common area) ^(Note1) | - | R |
| AI17 | LevelTripInfo | Level type trip information (Refer to address 0h0332 in the common area) ^(Note1) | - | R |
| AI18 | HWDIagInfo | H/W Diagnosis trip information (Refer to address 0h0333 in the common area)* | - | R |
| AI19 | WarningInfo | Warning information (Refer to address 0h0334 in the common area)* | - | R |
| AI20 | KiloWattHour | Output power by kW/h | kW/h | R |
| AI21 | MegaWattHour | Output power by MW/h | MW/h | R |

| Instance ID | Object Name | Description | Units | R/W |
|-------------|-------------------|---------------------|-------|-----|
| AI22 | PowerFactor | Power factor | - | R |
| AI23 | RunTimeDay | Run time by day | Day | R |
| AI24 | RunTimeMin | Run time by minute | Day | R |
| AI25 | PidOutValue | PID Output Value | % | R |
| AI26 | PidReferenceValue | PID Reference Value | % | R |
| AI27 | PidFeedbackValue | PID Feedback Value | % | R |

*Refer to the relevant addresses in 7.3.8 communication compatible common area parameters.

| Instance ID | Object Name | Description | R/W |
|-------------|--------------------|-----------------------------|-----|
| BI1 | Stopped | Stop state | R |
| BI2 | RunningForward | Running forward | R |
| BI3 | RunningReverse | Running reverse | R |
| BI4 | Tripped | Trip occurred | R |
| BI5 | Accelerating | Accelerating | R |
| BI6 | Decelerating | Decelerating | R |
| BI7 | SteadySpeed | Operating at steady speed | R |
| BI8 | RunningDC | Operating at a 0 step speed | R |
| BI9 | Stopping | Stopping | R |
| BI10 | FwdRunCommandState | Forward run command state | R |
| BI11 | RevRunCommandState | Reverse run command state | R |
| BI12 | P1 | P1 state | R |
| BI13 | P2 | P2 state | R |
| BI14 | P3 | P3 state | R |

| | | | |
|------|--------------|------------------------|---|
| BI15 | P4 | P4 state | R |
| BI16 | P5 | P5 state | R |
| BI17 | P6 | P6 state | R |
| BI18 | P7 | P7 state | R |
| BI19 | Relay1 | Relay1 state* | R |
| BI20 | Relay2 | Relay2 state* | R |
| BI21 | Relay3 | Relay3 state* | R |
| BI22 | Relay4 | Relay4 state* | R |
| BI23 | Relay5 | Relay5 state* | R |
| BI24 | Q1 | Q1 state | R |
| BI25 | SpeedSearch | Speed search operating | R |
| BI26 | HWOCS | H/W OCS occurred | R |
| BI27 | SWOCS | S/W OCS occurred | R |
| BI28 | RunningDwell | Dwell operating state | R |
| BI29 | SteadyState | Steady state | R |
| BI30 | Warning | Warning state | R |

7.4.5.5 Binary Input Object Instance

⚠ Caution

OUT-31–35 (Relay1–5) must be set to '0 (none)' to control outputs via communication.

7.4.5.6 MultiState Input Object Instance

| Instance ID | Object Name | Description | Units | R/W |
|-------------|--------------|-----------------------|---------------|-----|
| MSI1 | UnitsDisplay | Displays Unit setting | 1 Hz 2 RPM | R |

7.4.5.7 Error Message

| Display | Description |
|------------------|----------------------------|
| serviceserror+7 | Inconsistent parameters |
| propertyerror+9 | Invalid data type |
| serviceserror+10 | Invalid access method |
| serviceserror+11 | Invalid file start |
| serviceserror+29 | Service request denied |
| objecterror+31 | Unknown object |
| propertyerror+0 | Property other |
| propertyerror+27 | Read access denied |
| propertyerror+32 | Unknown property |
| propertyerror+37 | Value out of range |
| propertyerror+40 | Write access denied |
| propertyerror+42 | Invalid array index |
| clienterror+31 | Unknown device |
| resourceserror+0 | Resources other |
| clienterror+30 | Time out |
| abortreason+4 | Segmentation not supported |
| rejectreason+4 | Invalid tag |
| clienterror+0xFF | No invoke id |
| securityerror+26 | Password failure |

7.5 Metasys-N2 Communication

7.5.1 Metasys-N2 Quick Communication Start

Follow the instructions below to configure the Metasys-N2 network for a quick start.

- 1 Set COM-02 (Int485 Proto) to '5 (Metasys-N2)'.
- 2 Set the network communication speed to '9600 bps.'
- 3 Configure the communication modes and make sure that they are fixed to Data Bit 8 / No Parity Bit/ Start Bit 1 / Stop Bit 1.
- 4 Test the network and make sure Metasys-N2 communication is working properly.

7.5.2 Metasys-N2 Communication Standard

| Item | Standards |
|----------------------|---|
| Communication speed | 9600 bps |
| Control procedure | Asynchronous communications system |
| Communication system | Half duplex system |
| Cable | Twisted pair (1 pair and shield) |
| Character system | LS485: ASCII (8bit) Modbus-RTU: Binary (7/8 bit) Metasys-N2: ASCII (8bit) |
| Start/Stop bit | Start 1bit, Stop 1bit |
| Error check | RS485: Checksum (2byte) |
| | Modbus-RTU: CRC16 (2byte) Metastys-N2: CRC16 (2byte) |
| Parity check | None |

7.5.3 Metasys-N2 Protocol I/O Point Map

7.5.3.1 Analog Output

The output point map controlling the inverter from the Metasys-N2 master.

| No. | Name | Range | Unit | Description | |
|-----|-------------------|--------------|------------|-----------------------------|------------------------|
| AO1 | Command Frequency | 0.0–Max Freq | Hz | Command frequency setting** | |
| AO2 | Accel Time | 0.0–600.0 | Sec | ACC time setting* | |
| AO3 | Decel Time | 0.0–600.0 | Sec | DEC time setting* | |
| AO4 | Drive mode | 0 | KeyPad | - | Drive mode setting |
| | | 1 | Fx/Rx-1 | | |
| | | 2 | Fx/Rx-2 | | |
| | | 3 | Int. 485 | | |
| | | 4 | FieldBus | | |
| | | 5 | Time Event | | |
| AO5 | Freq mode | 0 | –KeyPad-1 | - | Frequency mode setting |
| | | 1 | –KeyPad-2 | | |
| | | 2 | V1 | | |
| | | 3 | –Reversed | | |
| | | 4 | V2 | | |
| | | 5 | I2 | | |
| | | 6 | Int485 | | |
| | | 7 | FieldBus | | |
| | | 8 | Reversed | | |
| | | 9 | Pulse | | |

⚠ Caution

- When PowerOn Resume (COM-96) is set to 'yes', value is saved even if the power of the inverter is disconnected. If PowerOn Resume (COM-96) is set to 'no', value is not saved when the power of the inverter is disconnected.
- Cannot set the value higher than the maximum frequency (DRV-20). The maximum frequency can be set by using the keypad. This value can be used when Freq Ref Src (DRV-07) is set to 'Int 485'.

7.5.3.2 Binary Output

The output point map controlling the inverter from the Metasys-N2 master.

| No. | Name | Range | Description |
|-----|---------------------|----------------|-----------------------|
| BO1 | Stop Command | 1: Stop | Stop command |
| BO2 | Run Forward Command | 1: Forward Run | Forward run command |
| BO3 | Run Reverse Command | 1: Reverse Run | Reverse run command |
| BO4 | Reset Fault | 1: Reset | Fault reset command |
| BO5 | Free-Run Stop | 1: Bx | Free-run stop command |

7.5.3.3 Analog Input

Metasys-N2 master monitors inverter state.

| No. | Name | Unit | Description |
|-----|------------------|------|---|
| AI1 | Output Current | Amps | Output current |
| AI2 | Output Frequency | Hz | Output frequency |
| AI3 | Output Speed | RPM | Output speed |
| AI4 | Trip Code | - | Trip code information (Refer to Common Area parameter address 0h000F)* |
| AI5 | Latch Trip Info1 | - | 'Latch' type fault trip information 1 (Refer to Common Area parameter address 0h0330)* |
| AI6 | Latch Trip Info2 | - | 'Latch' type fault trip information 2 |

| No. | Name | Unit | Description |
|------|-------------------------|------|--|
| | | | (Refer to Common Area parameter address 0h0331)* |
| A17 | Latch Trip Info3 | - | 'Latch' type fault trip information 3 (Refer to Common Area parameter address 0h0335)* |
| A18 | Level Trip Info | - | 'Level' type fault trip information (Refer to Common Area parameter address 0h0332)(1) |
| A19 | H/W Diagnosis Trip Info | - | H/W Diagnosis fault trip information (Refer to Common Area parameter address 0h0333)(1) |
| A110 | Warning Info | - | Warning information (Refer to Common Area parameter address 0h0334)(1) |

* Refer to [7.3.8 Compatible Common Area Parameter](#) on page [358](#).

7.5.3.4 Binary Input

Metasys-N2 master unit monitors the inverter input and output status in binary codes. The following table lists the binary codes used and their meanings.

| No. | Name | Description |
|------|--------------------|--|
| B11 | Stopped | 1 – Stopped |
| B12 | Running Forward | 1 – Forward operation is running. |
| B13 | Running Reverse | 1 – Reverse operation is running. |
| B14 | Tripped | 1 – Fault trip occurred. |
| B15 | Accelerating | 1 –Accelerating |
| B16 | Decelerating | 1 –Decelerating |
| B17 | Reached Full Speed | 1 –Running at a steady speed (frequency reference) |
| B18 | DC Braking | 1 – Running on DC power source |
| B19 | Stopping | 1–Stopping is in progress. |
| B110 | P1 Input | 1–True / 0 - False |
| B111 | P2 Input | 1–True / 0–False |

| No. | Name | Description |
|------|----------------|------------------|
| BI12 | P3 Input | 1–True / 0–False |
| BI13 | P4 Input | 1–True / 0–False |
| BI14 | P5 Input | 1–True / 0–False |
| BI15 | P6 Input | 1–True / 0–False |
| BI16 | P7 Input | 1–True / 0–False |
| BI17 | Relay1 State | 1–On / 0 - Off |
| BI18 | Relay2 State | 1–On / 0 - Off |
| BI19 | Relay3 State | 1–On / 0 - Off |
| BI20 | Relay4 State | 1–On / 0 - Off |
| BI21 | Relay5 State | 1–On / 0 - Off |
| BI22 | Q1 (OC1) State | 1–On / 0 - Off |

7.5.3.5 Error Code

| Defined Codes | Description |
|---------------|---|
| 00 | The device has been reset. Currently waiting for the 'Identity Yourself' command. |
| 01 | Undefined command |
| 02 | Checksum error has occurred. |
| 03 | Data size exceeded the input buffer (message is bigger than the device buffer size). |
| 05 | Data field error (input message size does not fit the command type) |
| 10 | Invalid data (message value is out of the range) |
| 11 | Invalid command for data type (command does not fit the message frame) |
| 12 | Command is not accepted (device has ignored a command due to a fault. The master device sends a 'Status Update Request'). |

8 Table of Functions

This chapter lists all the function settings for the H100 series inverter. Use the references listed in this document to set the parameters. If an entered set value is out of range, the

messages that will be displayed on the keypad are also provided in this chapter. In these situations, the [ENT] key will not operate to program the inverter.

8.1 Drive Group (DRV)

Data in the following table will be displayed only when the related code has been selected.

***O:** Write-enabled during operation, **Δ:** Write-enabled when operation stops, **X:** Write-disabled

| Code | Comm. Address | Name | LCD Display | Setting Range | Initial value | Property* | Ref. | |
|------|---------------|------------------------|----------------|---------------------------|---------------|---------------|----------------------|-----------------------|
| 00 | - | Jump Code | Jump Code | 1–99 | 9 | O | p.68 | |
| 01 | 0h1101 | Target frequency | Cmd Frequency | 0.00, Low Freq– High Freq | 0.00 | O | p.86 | |
| 02 | 0h1102 | Keypad run direction | Keypad Run Dir | 0 | Reverse | 1 | O | p.84 |
| | | | | 1 | Forward | | | |
| 03 | 0h1103 | Acceleration time | Acc Time | 0.0–600.0 (sec) | 20.0 | 0.75~90kW | O | p.111 |
| | | | | | 60.0 | 110~250kW | | |
| | | | | | 100.0 | 315~500kW | | |
| 04 | 0h1104 | Deceleration time | Dec Time | 0.0–600.0 (sec) | 30.0 | 0.75~90kW | O | p.111 |
| | | | | | 90.0 | 110~250kW | | |
| | | | | | 150.0 | 315~500kW | | |
| 05 | 0h1105 | HAND-OFF-AUTO Key Lock | KPD H.O.A Lock | 0 | Locked | 1: During Run | Δ | p.75 |
| | | | | 1 | During Run | | | |
| | | | | 2 | Unlocked | | | |
| 06 | 0h1106 | Command source | Cmd Source | 0 | Keypad | 1: Fx/Rx-1 | Δ | p.103 |
| | | | | 1 | Fx/Rx-1 | | | |

Table of Functions

| Code | Comm. Address | Name | LCD Display | Setting Range | | Initial value | Property* | Ref. |
|------|---------------|----------------------------|---------------|--------------------------|-------------|---------------|-----------|--------------------------------|
| | | | | 2 | Fx/Rx-2 | | | |
| | | | | 3 | Int 485 | | | |
| | | | | 4 | Field Bus | | | |
| | | | | 5 | Time Event | | | |
| 07 | 0h1107 | Frequency reference source | Freq Ref Src | 0 | Keypad-1 | 0: Keypad-1 | Δ | <u>p.86</u> |
| | | | | 1 | Keypad-2 | | | |
| | | | | 2 | V1 | | | |
| | | | | 4 | V2 | | | |
| | | | | 5 | I2 | | | |
| | | | | 6 | Int 485 | | | |
| | | | | 7 | FieldBus | | | |
| | | | | 9 | Pulse | | | |
| | | | | 10 ⁸ | V3 | | | |
| | | | | 11 | I3 | | | |
| 09 | 0h1109 | Control mode | Control Mode | 0 | V/F | 0: V/F | Δ | <u>p.121,</u> <u>p.157,</u> |
| | | | | 1 | Slip Compen | | | |
| 11 | 0h110B | Jog frequency | Jog Frequency | 0.00, Low Freq–High Freq | | 10.00 | ○ | <u>p.148</u> |
| 12 | 0h110C | Jog run acceleration time | Jog Acc Time | 0.0–600.0 (sec) | | 20.0 | ○ | <u>p.148</u> |
| 13 | 0h110D | Jog run deceleration time | Jog Dec Time | 0.0–600.0 (sec) | | 30.0 | ○ | <u>p.148</u> |
| 14 | 0h110E | Motor | Motor | 0 | 0.2 Kw | Dependent on | Δ | <u>p.210</u> |

⁸ '10(V3)~11(I3)' of DRV-07 are available when Extension IO option is equipped. Refer to Extension IO option manual for more detailed information.

| Code | Comm. Address | Name | LCD Display | Setting Range | Initial value | Property* | Ref. |
|------|---------------|----------|-------------|---------------|---------------------|---------------|------|
| | | capacity | Capacity | | (0.3HP) | motor setting | |
| | | | | 1 | 0.4 kW (0.5HP) | | |
| | | | | 2 | 0.75 kW (1.0HP) | | |
| | | | | 3 | 1.1 kW (1.5HP) | | |
| | | | | 4 | 1.5 kW (2.0HP) | | |
| | | | | 5 | 2.2 kW (3.0HP) | | |
| | | | | 6 | 3.0 kW (4.0HP) | | |
| | | | | 7 | 3.7 kW (5.0HP) | | |
| | | | | 8 | 4.0 kW (5.5HP) | | |
| | | | | 9 | 5.5 kW (7.5HP) | | |
| | | | | 10 | 7.5 kW (10.0HP) | | |
| | | | | 11 | 11.0 kW (15.0HP) | | |
| | | | | 12 | 15.0 kW (20.0HP) | | |
| | | | | 13 | 18.5 kW (25.0HP) | | |
| | | | | 14 | 22.0 kW (30.0HP) | | |
| | | | | 15 | 30.0 kW (40.0HP) | | |

Table of Functions

| Code | Comm. Address | Name | LCD Display | Setting Range | | Initial value | Property* | Ref. |
|------|----------------------|--------|-------------|---------------|----------------------|---------------|-----------|--------------|
| | | | | 16 | 37.0 kW (50.0HP) | | | |
| | | | | 17 | 45.0 kW (60.0HP) | | | |
| | | | | 18 | 55.0 kW (75.0HP) | | | |
| | | | | 19 | 75.0kW (100.0HP) | | | |
| | | | | 20 | 90.0kW (125.0HP) | | | |
| | | | | 21 | 110.0kW (150.0HP) | | | |
| | | | | 22 | 132.0kW (220.0HP) | | | |
| | | | | 23 | 160.0kW (250.0HP) | | | |
| | | | | 24 | 185.0kW (300.0HP) | | | |
| | | | | 25 | 220.0kW (350.0HP) | | | |
| | | | | 26 | 250.0kW (400.0HP) | | | |
| | | | | 27 | 315.0kW (500.0HP) | | | |
| | | | | 28 | 355.0kW (550.0HP) | | | |
| | | | | 29 | 400.0kW (650.0HP) | | | |
| 30 | 500.0kW (800.0HP) | | | | | | | |
| 15 | 0h110F | Torque | Torque | 0 | Manual | 0: Manual | Δ | <u>p.125</u> |

| Code | Comm. Address | Name | LCD Display | Setting Range | | Initial value | | Property* | Ref. |
|-----------------|---------------|--|----------------|--------------------------|----------------|-------------------|-----------|-----------|--------------|
| | | | | | | | | | |
| | | boost options | Boost | 1 | Auto 1 | | | | |
| | | | | 2 | Auto 2 | | | | |
| 16 ⁹ | 0h1110 | Forward Torque boost | Fwd Boost | 0.0–15.0 (%) | | 2.0 | 0.75~90kW | Δ | <u>p.125</u> |
| | | | | | | 1.0 | 110~500kW | | |
| 17 | 0h1111 | Reverse Torque boost | Rev Boost | 0.0–15.0 (%) | | 2.0 | 0.75~90kW | Δ | <u>p.125</u> |
| | | | | | | 1.0 | 110~500kW | | |
| 18 | 0h1112 | Base frequency | Base Freq | 30.00–400.00 (Hz) | | 60.00 | | Δ | <u>p.121</u> |
| 19 | 0h1113 | Start frequency | Start Freq | 0.01–10.00 (Hz) | | 0.50 | | Δ | <u>p.121</u> |
| 20 | 0h1114 | Maximum frequency | Max Freq | 40.00–400.00 (Hz) | | 60.00 | | Δ | <u>p.133</u> |
| 21 | 0h1115 | Select speed unit | Hz/Rpm Sel | 0 | Hz Display | 0: Hz Display | | O | <u>p.101</u> |
| | | | | 1 | RPM Display | | | | |
| 25 | 0h1119 | Hand mode operation frequency | HAND Cmd Freq | 0.00, Low Freq-High Freq | | 0.00 | | O | <u>p.81</u> |
| 26 | 0h111A | Hand mode operation Frequency reference source | HAND Ref Mode | 0 | HAND Parameter | 0: HAND Parameter | | Δ | <u>p.81</u> |
| | | | | 1 | Follow AUTO | | | | |
| 30 | 0h111E | kW/HP unit selection | kW/HP Unit Sel | 0 | kW | 1:HP | | O | - |
| | | | | 1 | HP | | | | |

⁹ DRV-16–17 are displayed when DRV-15 is set to '0 (Manual)'.

Table of Functions

| Code | Comm. Address | Name | LCD Display | Setting Range | | Initial value | Prope rty* | Ref. |
|------|---------------|-------------------------|-------------|---------------|----------------|---------------|------------|------|
| 91 | 0h115B | Smart Copy | SmartCopy | 0 | None | 0:None | Δ | |
| | | | | 1 | SmartDo wnload | | | |
| | | | | 3 | SmartUpl oad | | | |
| 98 | 0h1162 | Display I/O,S/W Version | I/O S/W Ver | - | - | - | X | - |

8.2 Basic Function Group (BAS)

Data in the following table will be displayed only when the related code has been selected.

***O: Write-enabled during operation, Δ: Write-enabled when operation stops, X: Write-disabled**

| Code | Comm. Address | Name | LCD Display | Setting Range | | Initial value | Prope rty* | Ref. |
|------|---------------|----------------------------|-------------|---------------|--------------|---------------|------------|--------------|
| 00 | - | Jump Code | Jump Code | 1-99 | | 20 | O | <u>p.68</u> |
| 01 | 0h1201 | Auxiliary reference source | Aux Ref Src | 0 | None | 0: None | Δ | <u>p.143</u> |
| | | | | 1 | V1 | | | |
| | | | | 3 | V2 | | | |
| | | | | 4 | I2 | | | |
| | | | | 6 | Pulse | | | |
| | | | | 7 | Int 485 | | | |
| | | | | 8 | FieldBus | | | |
| | | | | 10 | EPID1 Output | | | |
| 11 | EPID1 Fdb Val | | | | | | | |

| Code | Comm. Address | Name | LCD Display | Setting Range | | Initial value | Property* | Ref. |
|------------------|---------------|------------------------------------|---------------|------------------|----------------|---------------|-----------|-----------------------|
| | | | | | | | | |
| | | | | 12 ¹⁰ | V3 | | | |
| | | | | 13 | I3 | | | |
| 02 ¹¹ | 0h1202 | Auxiliary command calculation type | Aux Calc Type | 0 | M+(G*A) | 0: M+(G*A) | Δ | p.143 |
| | | | | 1 | M*(G*A) | | | |
| | | | | 2 | M/(G*A) | | | |
| | | | | 3 | M+[M*(G*A)] | | | |
| | | | | 4 | M+G*2*(A-50) | | | |
| | | | | 5 | M*[G*2*(A-50)] | | | |
| | | | | 6 | M/[G*2*(A-50)] | | | |
| | | | | 7 | M+M*G*2*(A-50) | | | |
| 03 | 0h1203 | Auxiliary command gain | Aux Ref Gain | -200.0-200.0 (%) | | 100.0 | ○ | p.143 |
| 04 | 0h1204 | Second command source | Cmd 2nd Src | 0 | Keypad | 1: Fx/Rx-1 | Δ | p.137 |
| | | | | 1 | Fx/Rx-1 | | | |
| | | | | 2 | Fx/Rx-2 | | | |
| | | | | 3 | Int 485 | | | |
| | | | | 4 | FieldBus | | | |
| | | | | 5 | Time Event | | | |
| 05 | 0h1205 | Second frequency source | Freq 2nd Src | 0 | Keypad-1 | 0: Keypad-1 | ○ | p.137 |
| | | | | 1 | Keypad-2 | | | |
| | | | | 2 | V1 | | | |

¹⁰ '12(V3)~13(I3)' of BAS-01 are available when Extension IO option is equipped. Refer to Extension IO option manual for more detailed information.

¹¹ BAS-02~03 are displayed when BAS-01 is not '0 (None)'.

Table of Functions

| Code | Comm. Address | Name | LCD Display | Setting Range | | Initial value | Prope rty* | Ref. |
|------|---------------|----------------------------|--------------|------------------|------------|-----------------------------|------------|-----------------------|
| | | | | 4 | V2 | | | |
| | | | | 5 | I2 | | | |
| | | | | 6 | Int 485 | | | |
| | | | | 7 | FieldBus | | | |
| | | | | 9 | Pulse | | | |
| | | | | 10 ¹² | V3 | | | |
| | | | | 11 | I3 | | | |
| 07 | 0h1207 | V/F pattern options | V/F Pattern | 0 | Linear | 0: Linear | Δ | p.121 |
| | | | | 1 | Square | | | |
| | | | | 2 | User V/F | | | |
| | | | | 3 | Square 2 | | | |
| 08 | 0h1208 | Acc/Dec standard frequency | Ramp T Mode | 0 | Max Freq | 0: Max Freq | Δ | p.111 |
| | | | | 1 | Delta Freq | | | |
| 09 | 0h1209 | Time scale settings | Time Scale | 0 | 0.01 sec | 1: 0.1 sec | Δ | p.111 |
| | | | | 1 | 0.1 sec | | | |
| | | | | 2 | 1 sec | | | |
| 10 | 0h120A | Input power frequency | 60/50 Hz Sel | 0 | 60 Hz | 0: 60 Hz | Δ | p.245 |
| | | | | 1 | 50 Hz | | | |
| 11 | 0h120B | Number of motor poles | Pole Number | 2-48 | | | Δ | p.157 |
| 12 | 0h120C | Rated slip speed | Rated Slip | 0-3000 (RPM) | | Dependen t on motor setting | Δ | p.157 |
| 13 | 0h120D | Motor rated current | Rated Curr | 0.0-1000.0 (A) | | | Δ | p.157 |

¹² '10(V3)~11(I3)' of BAS-05 are available when Extension IO option is equipped. Refer to Extension IO option manual for more detailed information.

| Code | Comm. Address | Name | LCD Display | Setting Range | Initial value | Property* | Ref. | |
|------------------|---------------|-----------------------|---------------|-------------------------------|----------------------------|-----------|-----------------------|-----------------------|
| 14 | 0h120E | Motor no-load current | NoloadCurrent | 0.0-1000.0 (A) | | Δ | p.157 | |
| 15 | 0h120F | Motor rated voltage | Rated Volt | 0, 170-480 (V) | 0 | Δ | p.127 | |
| 16 | 0h1210 | Motor efficiency | Efficiency | 70-100 (%) | Dependent on motor setting | Δ | p.210 | |
| 18 | 0h1212 | Trim power display | Trim Power % | 70-130 (%) | 100 | ○ | - | |
| 19 | 0h1213 | Input power voltage | AC Input Volt | 170~264V | 0.75~18.5kW | 220 V | ○ | p.245 |
| | | | | 320~528V | 0.75~90kW | 380 V | | |
| | | | | 320~550V | 110~500kW | | | |
| 20 | - | Auto Tuning | Auto Tuning | 0 | None | 0: None | Δ | p.210 |
| | | | | 1 | All (Rotation type) | | | |
| | | | | 2 | All (Static type) | | | |
| | | | | 3 | Rs+ Lsigma (Rotation type) | | | |
| 21 | - | Stator resistor | Rs | 0.000-9.999 (Ω) | Dependent on motor setting | Δ | p.210 | |
| 22 | - | Leakage inductance | Lsigma | 0.00-99.99 (mH) | | Δ | p.210 | |
| 41 ¹³ | 0h1229 | User frequency 1 | User Freq 1 | 0.00 - Maximum frequency (Hz) | 15.00 | Δ | p.123 | |
| 42 | 0h122A | User | User Volt | 0-100 (%) | 25 | Δ | p.123 | |

¹³BAS-41-48 are displayed when BAS-07 or M2-25 is set to '2 (User V/F)'.

Table of Functions

| Code | Comm. Address | Name | LCD Display | Setting Range | Initial value | Property* | Ref. |
|------------------|---------------|------------------------------|-------------|-------------------------------|---------------|-----------|-----------------------|
| | | voltage1 | 1 | | | | |
| 43 | 0h122B | User frequency 2 | User Freq 2 | 0.00-Maximum frequency (Hz) | 30.00 | Δ | p.123 |
| 44 | 0h122C | User voltage2 | User Volt 2 | 0-100 (%) | 50 | Δ | p.123 |
| 45 | 0h122D | User frequency 3 | User Freq 3 | 0.00 - Maximum frequency (Hz) | 45.00 | Δ | p.123 |
| 46 | 0h122E | User voltage3 | User Volt 3 | 0-100 (%) | 75 | Δ | p.123 |
| 47 | 0h122F | User frequency 4 | User Freq 4 | 0.00 - Maximum frequency (Hz) | 60.00 | Δ | p.123 |
| 48 | 0h1230 | User voltage4 | User Volt 4 | 0-100 (%) | 100 | Δ | p.123 |
| 50 ¹⁴ | 0h1232 | Multi-step speed frequency 1 | Step Freq-1 | Low Freq- High Freq | 10.00 | O | p.101 |
| 51 | 0h1233 | Multi-step speed frequency 2 | Step Freq-2 | Low Freq- High Freq | 20.00 | O | p.101 |
| 52 | 0h1234 | Multi-step speed frequency 3 | Step Freq-3 | Low Freq- High Freq | 30.00 | O | p.101 |
| 53 | 0h1235 | Multi-step speed frequency 4 | Step Freq-4 | Low Freq- High Freq | 40.00 | O | p.101 |
| 54 | 0h1236 | Multi-step speed | Step Freq-5 | Low Freq- High Freq | 50.00 | O | p.101 |

¹⁴BAS-50–56 are displayed when IN-65-71 is set to 'Speed-L/M/H'.

| Code | Comm. Address | Name | LCD Display | Setting Range | Initial value | Property* | Ref. |
|------------------|---------------|-------------------------------|-------------|---------------------|---------------|-----------|-----------------------|
| | | frequency 5 | | | | | |
| 55 | 0h1237 | Multi-step speed frequency 6 | Step Freq-6 | Low Freq- High Freq | 60.00 | O | p.101 |
| 56 | 0h1238 | Multi-step speed frequency 7 | Step Freq-7 | Low Freq-High Freq | 60.00 | O | p.101 |
| 70 | 0h1246 | Multi-step acceleration time1 | Acc Time-1 | 0.0-600.0 (sec) | 20.0 | O | p.113 |
| 71 | 0h1247 | Multi-step deceleration time1 | Dec Time-1 | 0.0-600.0 (sec) | 20.0 | O | p.113 |
| 72 ¹⁵ | 0h1248 | Multi-step acceleration time2 | Acc Time-2 | 0.0-600.0 (sec) | 30.0 | O | p.113 |
| 73 | 0h1249 | Multi-step deceleration time2 | Dec Time-2 | 0.0-600.0 (sec) | 30.0 | O | p.113 |
| 74 | 0h124A | Multi-step acceleration time3 | Acc Time-3 | 0.0-600.0 (sec) | 40.0 | O | p.113 |
| 75 | 0h124B | Multi-step deceleration time3 | Dec Time-3 | 0.0-600.0 (sec) | 40.0 | O | p.113 |
| 76 | 0h124C | Multi-step acceleration time4 | Acc Time-4 | 0.0-600.0 (sec) | 50.0 | O | p.113 |
| 77 | 0h124D | Multi-step deceleration time4 | Dec Time-4 | 0.0-600.0 (sec) | 50.0 | O | p.113 |
| 78 | 0h124E | Multi-step acceleration time5 | Acc Time-5 | 0.0-600.0 (sec) | 40.0 | O | p.113 |

¹⁵ BAS-72–83 are displayed when IN-65–71 is set to 'Xcel-L/M/H'

Table of Functions

| Code | Comm. Address | Name | LCD Display | Setting Range | Initial value | Property* | Ref. |
|------|---------------|-------------------------------|-------------|-----------------|---------------|-----------|-----------------------|
| | | n time5 | | | | | |
| 79 | 0h124F | Multi-step deceleration time5 | Dec Time-5 | 0.0-600.0 (sec) | 40.0 | O | p.113 |
| 80 | 0h1250 | Multi-step acceleration time6 | Acc Time-6 | 0.0-600.0 (sec) | 30.0 | O | p.113 |
| 81 | 0h1251 | Multi-step deceleration time6 | Dec Time-6 | 0.0-600.0 (sec) | 30.0 | O | p.113 |
| 82 | 0h1252 | Multi-step acceleration time7 | Acc Time-7 | 0.0-600.0 (sec) | 20.0 | O | p.113 |
| 83 | 0h1253 | Multi-step deceleration time7 | Dec Time-7 | 0.0-600.0 (sec) | 20.0 | O | p.113 |

8.3 Expanded Function Group (ADV)

Data in the following table will be displayed only when the related code has been selected.

*O: Write-enabled during operation, Δ: Write-enabled when operation stops, X: Write-disabled

| Code | Comm. Address | Name | LCD Display | Setting Range | Initial Value | Property* | Ref. | |
|------------------|---------------|----------------------|-------------|---------------|---------------|-----------|-----------------------|-----------------------|
| 00 | - | Jump Code | Jump Code | 1-99 | 24 | O | p.68 | |
| 01 | 0h1301 | Acceleration pattern | Acc Pattern | 0 | Linear | 0: Linear | Δ | p.117 |
| | | | | 1 | S-curve | | | |
| 02 | 0h1302 | Deceleration pattern | Dec Pattern | 0 | Linear | 0: Linear | Δ | p.117 |
| | | | | 1 | S-curve | | | |
| 03 ¹⁶ | 0h1303 | S-curve | Acc S | 1-100 (%) | 40 | Δ | p.117 | |

¹⁶ADV-03-04 are displayed when ADV-01 is set to '1 (S-curve)'.

| Code | Comm. Address | Name | LCD Display | Setting Range | Initial Value | Property* | Ref. | |
|------------------|---------------|--|----------------|-------------------|---------------|-----------|-----------------------|-----------------------|
| | | acceleration start point gradient | Start | | | | | |
| 04 | 0h1304 | S-curve acceleration end point gradient | Acc S End | 1–100 (%) | 40 | Δ | p.117 | |
| 05 ¹⁷ | 0h1305 | S-curve deceleration start point gradient | Dec S Start | 1–100 (%) | 40 | Δ | p.117 | |
| 06 | 0h1306 | S-curve deceleration end point gradient | Dec S End | 1–100 (%) | 40 | Δ | p.117 | |
| 07 | 0h1307 | Start Mode | Start Mode | 0 | Acc | 0: Acc | Δ | p.128 |
| | | | | 1 | DC-Start | | | |
| 08 | 0h1308 | Stop Mode | Stop Mode | 0 | Dec | 0: Dec | Δ | p.129 |
| | | | | 1 | DC-Brake | | | |
| | | | | 2 | Free-Run | | | |
| | | | | 4 | Power Braking | | | |
| 09 | 0h1309 | Selection of prohibited rotation direction | Run Prevent | 0 | None | 0: None | Δ | p.107 |
| | | | | 1 | Forward Prev | | | |
| | | | | 2 | Reverse Prev | | | |
| 10 | 0h130A | Starting with power on | Power-on Run | 0 | No | 0: No | O | p.108 |
| | | | | 1 | Yes | | | |
| 11 ¹⁸ | 0h130B | Power-on run delay time | Power-On Delay | 0.0 -6000.0 (sec) | 0.0 | O | p.108 | |

¹⁷ADV-05–06 are displayed when ADV-02 is set to '1 (S-curve)'.

¹⁸ADV-11 is displayed when ADV-10 is set to '1 (YES)'.

Table of Functions

| Code | Comm. Address | Name | LCD Display | Setting Range | Initial Value | Property* | Ref. |
|------------------|---------------|--|----------------|--|---------------|-----------|-----------------------|
| 12 ¹⁹ | 0h130C | DC braking time at startup | DC-Start Time | 0.00-60.00 (sec) | 0.00 | Δ | p.128 |
| 13 | 0h130D | Amount of applied DC | DC Inj Level | 0-200 (%) | 50 | Δ | p.128 |
| 14 ²⁰ | 0h130E | Output blocking time before DC braking | DC-Block Time | 0.00- 60.00 (sec) | 0.00 | Δ | p.129 |
| | | | | | 2.00 | | |
| 15 | 0h130F | DC braking time | DC-Brake Time | 0.00- 60.00 (sec) | 1.00 | Δ | p.129 |
| 16 | 0h1310 | DC braking rate | DC-Brake Level | 0-200 (%) | 50 | Δ | p.129 |
| 17 | 0h1311 | DC braking frequency | DC-Brake Freq | Startfrequency-60 Hz | 5.00 | Δ | p.129 |
| 20 | 0h1314 | Dwell frequency on acceleration | Acc Dwell Freq | Start frequency-Maximum frequency (Hz) | 5.00 | Δ | p.155 |
| 21 | 0h1315 | Dwell operation time on acceleration | Acc Dwell Time | 0.0-60.0 (sec) | 0.0 | Δ | p.155 |
| 22 | 0h1316 | Dwell frequency on deceleration | Dec Dwell Freq | Start frequency-Maximum frequency (Hz) | 5.00 | Δ | p.155 |
| 23 | 0h1317 | Dwell operation time on deceleration | Dec Dwell Time | 0.0-60.0 (sec) | 0.0 | Δ | p.155 |

¹⁹ADV-12 is displayed when ADV-07 is set to '1 (DC-Start)'.

²⁰ADV-14 is displayed when ADV-08 is set to '1 (DC-Brake)'.

| Code | Comm. Address | Name | LCD Display | Setting Range | | Initial Value | Property* | Ref. |
|------------------|---------------|-----------------------------|---------------|--|--------|---------------|-----------|-----------------------|
| | | | | 0 | No | | | |
| 24 | 0h1318 | Frequency limit | Freq Limit | 0 | No | 0: No | Δ | p.133 |
| | | | | 1 | Yes | | | |
| 25 | 0h1319 | Frequency lower limit value | Freq Limit Lo | 0.00-Upper limit frequency (Hz) | | 0.50 | Δ | p.133 |
| 26 | 0h131A | Frequency upper limit value | Freq Limit Hi | Lower limit frequency-Maximum frequency (Hz) | | Max freq | Δ | p.133 |
| 27 | 0h131B | Frequency jump | Jump Freq | 0 | No | 0: No | Δ | p.136 |
| | | | | 1 | Yes | | | |
| 28 ²¹ | 0h131C | Jump frequency lower limit1 | Jump Lo 1 | 0.00-Jump frequency upper limit1 (Hz) | | 10.00 | O | p.136 |
| 29 | 0h131D | Jump frequency upper limit1 | Jump Hi 1 | Jump frequency lower limit1-Maximum frequency (Hz) | | 15.00 | O | p.136 |
| 30 | 0h131E | Jump frequency lower limit2 | Jump Lo 2 | 0.00-Jump frequency upper limit2 (Hz) | | 20.00 | O | p.136 |
| 31 | 0h131F | Jump frequency upper limit2 | Jump Hi 2 | Jump frequency lower limit2-Maximum frequency (Hz) | | 25.00 | O | p.136 |
| 32 | 0h1320 | Jump frequency lower limit3 | Jump Lo 3 | 0.00-Jump frequency upper limit3 (Hz) | | 30.00 | O | p.136 |
| 33 | 0h1321 | Jump frequency upper limit3 | Jump Hi 3 | Jump frequency lower limit3-Maximum frequency (Hz) | | 35.00 | O | p.136 |
| 50 | 0h1332 | Energy saving | E-Save Mode | 0 | None | 0: None | Δ | p.232 |
| | | | | 1 | Manual | | | |

²¹ADV-28-33 are displayed when ADV-27 is set to '1 (Yes)'.

Table of Functions

| Code | Comm. Address | Name | LCD Display | Setting Range | Initial Value | Property* | Ref. |
|------------------|---------------|---------------------------------------|-----------------|-----------------------------|---------------|-----------|-----------------------|
| | | operation | | 2 Auto | | | |
| 51 ²² | 0h1333 | Energy saving level | Energy Save | 0-30 (%) | 0 | O | p.232 |
| 52 | 0h1334 | Energy saving point search time | E-Save Det T | 0.0-100.0 (sec) | 20.0 | Δ | p.232 |
| 60 | 0h133C | Acc/Dec time transition frequency | Xcel Change Fr | 0.00-Maximum frequency (Hz) | 0.00 | Δ | p.115 |
| 64 | 0h1340 | Cooling fan control | Fan Control | 0 During Run | 0: During Run | O | p.244 |
| | | | | 1 Always ON | | | |
| | | | | 2 Temp Control | | | |
| 65 | 0h1341 | Up/Down operation frequency save | U/D Save Mode | 0 No | 0: No | O | p.150 |
| | | | | 1 Yes | | | |
| 66 | 0h1342 | Output contact On/Off control options | On/Off Ctrl Src | 0 None | 0: None | O | p.282 |
| | | | | 1 V1 | | | |
| | | | | 3 V2 | | | |
| | | | | 4 I2 | | | |
| | | | | 6 Pulse | | | |
| | | | | 7 ²³ V3 | | | |
| | | | | 8 I3 | | | |
| 67 | 0h1343 | Output | On-Ctrl | Output contact | 90.00 | Δ | p.282 |

²²ADV-51 is displayed when ADV-50 is set to '1 (Manual)'.

ADV-52 is displayed when ADV-50 is set to '2 (Auto)'.

²³ '10(V3)~11(I3)' of ADV-66 are available when Extension IO option is equipped. Refer to Extension IO option manual for more detailed information.

| Code | Comm. Address | Name | LCD Display | Setting Range | Initial Value | Property* | Ref. | |
|------------------|---------------|--|-----------------|------------------------------------|---------------|------------------|-----------------------|-----------------------|
| | | contact On level | Level | off level-100.00% | | | | |
| 68 | 0h1344 | Output contact Off level | Off-Ctrl Level | -100.00-outputcontact on level (%) | 10.00 | Δ | p.282 | |
| 70 | 0h1346 | Safe operation selection | Run En Mode | 0 | Always Enable | 0: Always Enable | Δ | p.153 |
| | | | | 1 | DI Dependent | | | |
| 71 ²⁴ | 0h1347 | Safe operation stop options | Run Dis Stop | 0 | Free-Run | 0: Free-Run | Δ | p.153 |
| | | | | 1 | Q-Stop | | | |
| | | | | 2 | Q-Stop Resume | | | |
| 72 | 0h1348 | Safe operation deceleration time | Q-Stop Time | 0.0-600.0 (sec) | 5.0 | O | p.153 | |
| 74 | 0h134A | Selection of regeneration evasion function for press | RegenA vdSel | 0 | No | 0: No | Δ | p.289 |
| | | | | 1 | Yes | | | |
| 75 | 0h134B | Voltage level of regeneration evasion motion for press | RegenA vd Level | 200 V: 300-400 V | 350 | Δ | p.289 | |
| | | | | 400 V: 600-800 V | 700 | | | |
| 76 ²⁵ | 0h134C | Compensation frequency limit of regeneration evasion for press | CompFreq Limit | 0.00-10.00 Hz | 1.00 | Δ | p.289 | |

²⁴ADV-71–72 are displayed when ADV-70 is set to '1 (DI Dependent)'.

²⁵ADV-76–78 are displayed when ADV-74 is set to '1 (Yes)'.

Table of Functions

| Code | Comm. Address | Name | LCD Display | Setting Range | Initial Value | Property* | Ref. |
|------|---------------|---------------------------------------|-------------------|--------------------|---------------|-----------|--------------|
| 77 | 0h134D | Regeneration evasion for press P-Gain | RegenA vdPgain | 0.0-100.0% | 50.0 | O | <u>p.289</u> |
| 78 | 0h134E | Regeneration evasion for press I gain | RegenA vdlgain | 20-30000 (msec) | 500 | O | <u>p.289</u> |

8.4 Control Function Group (CON)

Data in the following table will be displayed only when the related code has been selected.

*O: Write-enabled during operation, Δ: Write-enabled when operation stops, X: Write-disabled

| Code | Comm. Address | Name | LCD Display | Setting Range | Initial Value | Property* | Ref. |
|------|---------------|--|---------------|---------------------|-------------------|-----------|-----------------------|
| 00 | - | Jump Code | Jump Code | 1-99 | 4 | O | p.68 |
| 04 | 0h1404 | Carrier frequency | Carrier Freq | 1.0~15.0 (kHz) | 0.75~90 kW 3.0 | O | p.240 |
| | | | | 1.0~5.0 (kHz) | 110~355 kW 2.0 | | |
| | | | | 1.0~4.0 (kHz) | 400~500 kW 1.5 | | |
| 05 | 0h1405 | Switching mode | PWM Mode | 0 | Normal PWM | Δ | p.240 |
| | | | | 1 | Low leakage PWM | | |
| 13 | 0h140D | Anti-hunting regulator mode | AHR Sel | 0 | No | Δ | p.229 |
| | | | | 1 | Yes | | |
| 14 | 0h140E | Anti-hunting regulator P-Gain | AHR P-Gain | 0-32767 | 1000 | O | p.229 |
| 15 | 0h140F | Anti-hunting regulator start frequency | AHR Low Freq | 0.00-AHR High Freq | 0.50 | O | p.229 |
| 16 | 0h1410 | Anti-hunting regulator end frequency | AHR High Freq | AHR Low Freq-400.00 | 400.00 | O | p.229 |
| 17 | 0h1411 | Anti-hunting regulator compensation voltage limit rate | AHR limit | 0-20 | 2 | O | p.229 |

Table of Functions

| Code | Comm. Address | Name | LCD Display | Setting Range | Initial Value | Prope rty* | Ref. | |
|------------------|---------------|----------------------------------|----------------|-----------------|--|-------------------|-----------------------|-----------------------|
| 21 ²⁶ | 0h1415 | Auto torque boost filter gain | ATB Filt Gain | 1 – 9999 (msec) | 10 | O | p.126 | |
| 22 | 0h1416 | Auto torque boost voltage | ATB Volt Gain | 0.0-300.0% | 100.0 | O | p.126 | |
| 70 | 0h1446 | Speed search mode selection | SS Mode | 0 | Flying Start-1 | 0: Flying Start-1 | Δ | p.234 |
| | | | | 1 | Flying Start-2 | | | |
| 71 | 0h1447 | Speed search operation selection | Speed Search | Bit | 0000-1111 | 0000 | Δ | p.234 |
| | | | | Bit 0 | Speed search on acceleration | | | |
| | | | | Bit 1 | Restart after trips (other than LV trip) | | | |
| | | | | Bit 2 | Restart after instantaneous interruption | | | |
| | | | | Bit 3 | Power-on run | | | |
| 72 ²⁷ | 0h1448 | Speed search | SS Sup-Current | 50–120 (%) | 90 | 0.75~250kW | O | p.234 |

²⁶CON-21–22 are displayed when DRV-15 is set to 'Auto 2'.

²⁷CON-72 is displayed after Flying Start-1 and when any CON-71 bit is set to '1'.

| Code | Comm. Address | Name | LCD Display | Setting Range | Initial Value | | Property* | Ref. |
|------------------|---------------|---------------------------------------|-----------------------------------|------------------------------------|---|-----------|-----------|--------------|
| | | | | | | | | |
| | | reference current | | | 80 | 315~500kW | | |
| 73 ²⁸ | 0h1449 | Speed search proportional gain | SS P-Gain | 0-9999 | Flying Start-1 : 100 | | O | <u>p.234</u> |
| | | | | | Flying Start-2 : Dependent on motor setting | | | |
| 74 | 0h144A | Speed search integral gain | SS I-Gain | 0-9999 | Flying Start-1 : 200 | | O | <u>p.234</u> |
| | | | | | Flying Start-2 : Dependent on motor setting | | | |
| 75 | 0h144B | Output block time before speed search | SS Block Time | 0.0-60.0 (sec) | 1.0 | | Δ | <u>p.234</u> |
| 77 | 0h144D | Energy buffering selection | KEB Select | 0 | No | 0: No | Δ | <u>p.190</u> |
| | | | | 1 | Yes | | | |
| 78 ²⁹ | 0h144E | Energy buffering start level | KEB Start Lev | 110.0-140.0 (%) | 125.0 | 0.75~90kW | Δ | <u>p.190</u> |
| | | | | | 115.0 | 110~500kW | | |
| 79 | 0h144F | Energy buffering stop level | KEB Stop Lev | KEB Start Lev * 125.0-145.0 (%) | 130.0 | 0.75~90kW | Δ | <u>p.190</u> |
| | | | | | 125.0 | 110~500kW | | |
| 80 | 0h1450 | Energy buffering slip gain | KEB Slip Gain buffering slip gain | 0-20000 | 300 | | O | <u>p.190</u> |
| 81 | 0h1451 | Energy buffering P- | KEB P Gain | 0-20000 | 1000 | | O | <u>p.190</u> |

²⁸CON-73–75 are displayed when any CON-71bit is set to '1'.

²⁹CON-78–83 are displayed when CON-77 is set to '1 (Yes)'.

Table of Functions

| Code | Comm. Address | Name | LCD Display | Setting Range | Initial Value | Property* | Ref. |
|------|---------------|------------------------------------|--------------|---------------|---------------|-----------|-----------------------|
| | | Gain | | | | | |
| 82 | 0h1452 | Energy buffering I gain | KEB I Gain | 1-20000 | 500 | O | p.190 |
| 83 | 0h1453 | Energy buffering acceleration time | KEB Acc Time | 0.0-600.0 | 10.0 | O | p.190 |
| | | | | | 30.0 | | |

8.5 Input Terminal Group (IN)

Data in the following table will be displayed only when the related code has been selected.

*O: Write-enabled during operation, Δ: Write-enabled when operation stops, X: Write-disabled

| Code | Comm. Address | Name | LCD Display | Setting Range | Initial Value | Property* | Ref. |
|------------------|---------------|-----------------------------------|---------------|--|-------------------|-------------|----------------------|
| 00 | - | Jump Code | Jump Code | 1-99 | 65 | O | p.68 |
| 01 | 0h1501 | Frequency at maximum analog input | Freq at 100% | Start frequency- Maximum frequency (Hz) | Maximum frequency | O | p.88 |
| 05 ³⁰ | 0h1505 | V1 input voltage display | V1 Monitor(V) | 0~12.00(V) or -12.00~12.00 (V) | 0.00 | X | p.88 |
| 06 | 0h1506 | V1 input polarity selection | V1 Polarity | 0 | Unipolar | 0: Unipolar | Δ |
| | | | | 1 | Bipolar | | |
| 07 | 0h1507 | Time constant of V1 input filter | V1 Filter | 0~10000 (ms) | 10 | O | p.88 |
| 08 | 0h1508 | V1 minimum | V1 Volt x1 | 0.00-10.00 (V) | 0.00 | O | p.88 |

³⁰'IN-05' setting range can be changed according to the 'IN-06' settings.

| Code | Comm. Address | Name | LCD Display | Setting Range | Initial Value | Property* | Ref. |
|------------------|---------------|----------------------------------|--------------|------------------|---------------|-----------|--|
| | | input voltage | | | | | |
| 09 | 0h1509 | Output at V1 minimum voltage (%) | V1 Perc y1 | 0.00-100.00 (%) | 0.00 | O | <u>p.88</u> |
| 10 | 0h150A | V1 maximum input voltage (%) | V1 Volt x2 | 0.00-12.00 (V) | 10.00 | O | <u>p.88</u> |
| 11 | 0h150B | Output at V1 maximum voltage (%) | V1 Perc y2 | 0.00-100.00 (%) | 100.00 | O | <u>p.88</u> |
| 12 ³¹ | 0h150C | V1 input at minimum voltage (%) | V1 -Volt x1' | -10.00- 0.00 (V) | 0.00 | O | <u>p.오류</u> <u>!</u> <u>확인</u> <u>가</u> <u>정의되</u> <u>어</u> <u>있지</u> <u>않습니</u> <u>다.</u> |
| 13 | 0h150D | Output at V1 minimum voltage (%) | V1 -Perc y1' | -100.00-0.00 (%) | 0.00 | O | <u>p.오류</u> <u>!</u> <u>확인</u> <u>가</u> <u>정의되</u> <u>어</u> <u>있지</u> <u>않습니</u> <u>다.</u> |
| 14 | 0h150E | V1 maximum input voltage | V1 -Volt x2' | -12.00- 0.00 (V) | -10.00 | O | <u>p.오류</u> <u>!</u> |

³¹IN-12-17 are displayed when IN-06 is set to '1 (Bipolar)'.

Table of Functions

| Code | Comm. Address | Name | LCD Display | Setting Range | Initial Value | Property* | Ref. |
|------------------|---------------|----------------------------------|----------------|-------------------------------------|---------------|-----------|---|
| | | (%) | | | | | <u>책갈피</u> <u>가</u> <u>정의되</u> <u>어</u> <u>있지</u> <u>않습니</u> <u>다.</u> |
| 15 | 0h150F | Output at V1 maximum voltage (%) | V1 -Perc y2' | -100.00-0.00 (%) | -100.00 | O | <u>p.오류</u> <u>!</u> <u>책갈피</u> <u>가</u> <u>정의되</u> <u>어</u> <u>있지</u> <u>않습니</u> <u>다.</u> |
| 16 | 0h1510 | V2 rotation direction change | V1 Inverting | 0 No 1 Yes | 0: No | O | <u>p.88</u> |
| 17 | 0h1511 | V1 quantization change | V1 Quantizing | 0.00 ³² , 0.04-10.00 (%) | 0.04 | O | <u>p.88</u> |
| 20 ³³ | 0h1514 | Temperature monitor | T1 Monitor | 0.00 - 100.00 (%) | - | X | <u>p.309</u> |
| 35 ³⁴ | 0h1523 | V2 input rate monitor | V2 Monitor (V) | 0.00-12.00 (V) | 0.00 | O | <u>p.96</u> |

³²* Quantizing is disabled if '0' is selected.

³³IN-20 is displayed when the analog current/voltage input circuit selection switch (SW3) is selected on T1.

³⁴IN-35-47 are displayed when the analog current/voltage input circuit selection switch (SW4) is selected on V2.

| Code | Comm. Address | Name | LCD Display | Setting Range | Initial Value | Property* | Ref. | |
|------------------|---------------|----------------------------------|-----------------|---|---------------|-----------|-------------|------|
| 37 | 0h1525 | V2 input filter time | V2 Filter | 0-10000 (msec) | 10 | O | p.96 | |
| 38 | 0h1526 | V2 minimum input voltage | V2 Volt x1 | 0.00-10.00 (V) | 0.00 | O | p.96 | |
| 39 | 0h1527 | Output at V2 minimum voltage (%) | V2 Perc y1 | 0.00-100.00 (%) | 0.00 | O | p.96 | |
| 40 | 0h1528 | V2 maximum input voltage | V2 Volt x2 | 0.00-10.00 (V) | 10.00 | O | p.96 | |
| 41 | 0h1529 | Output at V2 maximum voltage (%) | V2 Perc y2 | 0.00-100.00 (%) | 100.00 | O | p.96 | |
| 46 | 0h152E | V2 Rotation direction options | V2 Inverting | 0 | No | 0: No | O | p.96 |
| | | | | 1 | Yes | | | |
| 47 | 0h152F | V2 Quantizing level | V2 Quantizing | 0.00 ³⁵ , 0.04- 10.00 (%) | 0.04 | O | p.96 | |
| 50 ³⁶ | 0h1532 | I2 input monitor | I2 Monitor (mA) | 0–24 (mA) | 0 | O | p.93 | |
| 52 | 0h1534 | I2 input filter time | I2 Filter | 0–10000 (msec) | 10 | O | p.93 | |
| 53 | 0h1535 | I2 minimum input power supply | I2 Curr x1 | 0.00-20.00 (mA) | 4.00 | O | p.93 | |
| 54 | 0h1536 | Output at I2 maximum current (%) | I2 Perc y1 | 0.00-100.00 (%) | 0.00 | O | <u>p.93</u> | |
| 55 | 0h1537 | I2 maximum input current | I2 Curr x2 | I2 Curr x1 - 24.00 (mA) | 20.00 | O | <u>p.93</u> | |
| 56 | 0h1538 | Output at I2 maximum current (%) | I2 Perc y2 | 0.00-100.00 (%) | 100.00 | O | <u>p.93</u> | |

³⁵* Quantizing is disabled if '0' is selected.

³⁶I_N-50–62 are displayed when the analog current/voltage input circuit selection switch (SW5) is selected on I₂.

Table of Functions

| Code | Comm. Address | Name | LCD Display | Setting Range | | Initial Value | Property* | Ref. |
|------|---------------|-------------------------------|---------------|--------------------------------------|---------------|---------------|-----------|-----------------------|
| 61 | 0h153D | I2 rotation direction options | I2 Inverting | 0 | No | 0: No | O | p.93 |
| | | | | 1 | Yes | | | |
| 62 | 0h153E | I2 Quantizing level | I2 Quantizing | 0.00 ³⁷ 0.04-10.00 (%) | | 0.04 | O | p.93 |
| 65 | 0h1541 | P1 Px terminal configuration | P1 Define | 0 | None | 1: Fx | Δ | p.103 |
| | | | | 1 | Fx | | | |
| 66 | 0h1542 | P2 Px terminal configuration | P2 Define | 2 | Rx | 2: Rx | Δ | p.103 |
| 67 | 0h1543 | P3 Px terminal configuration | P3 Define | 3 | RST | 5: BX | Δ | p.329 |
| 68 | 0h1544 | P4 Px terminal configuration | P4 Define | 4 | External Trip | 3: RST | Δ | p.328 |
| 69 | 0h1545 | P5 Px terminal configuration | P5 Define | 5 | BX | 7: Sp-L | Δ | p.328 |
| 70 | 0h1546 | P6 Px terminal configuration | P6 Define | 6 | JOG | 8: Sp-M | Δ | p.148 |
| 71 | 0h1547 | P7 Px terminal configuration | P7 Define | 7 | Speed-L | 9: Sp-H | Δ | p.101 |
| | | | | 8 | Speed-M | | | p.101 |
| | | | | 9 | Speed-H | | | p.101 |
| | | | | 11 | XCEL-L | | | p.113 |
| | | | | 12 | XCEL-M | | | p.113 |
| | | | | 13 | XCEL-H | | | p.113 |
| | | | | 14 | XCEL Stop | | | p.119 |

^{37*} Quantizing is disabled if '0' is selected.

| Code | Comm. Address | Name | LCD Display | Setting Range | | Initial Value | Property* | Ref. |
|------|---------------|------|-------------|---------------|----------------|---------------|-----------|-----------------------|
| | | | | 15 | RUN Enable | | | p.153 |
| | | | | 16 | 3-Wire | | | p.152 |
| | | | | 17 | 2nd Source | | | p.137 |
| | | | | 18 | Exchange | | | p.243 |
| | | | | 19 | Up | | | p.150 |
| | | | | 20 | Down | | | p.150 |
| | | | | 22 | U/D Clear | | | p.150 |
| | | | | 23 | Analog Hold | | | p.99 |
| | | | | 24 | I-Term Clear | | | p.159 |
| | | | | 25 | PID Openloop | | | p.159 |
| | | | | 26 | PID Gain2 | | | p.159 |
| | | | | 27 | PID Ref Change | | | p.119 |
| | | | | 28 | 2nd Motor | | | p.241 |
| | | | | 29 | Interlock 1 | | | p.275 |
| | | | | 30 | Interlock 2 | | | p.275 |
| | | | | 31 | Interlock 3 | | | p.275 |
| | | | | 32 | Interlock 4 | | | p.275 |
| | | | | 33 | Interlock 5 | | | p.275 |
| | | | | 34 | Pre | | | - |

Table of Functions

| Code | Comm. Address | Name | LCD Display | Setting Range | Initial Value | Property* | Ref. |
|------|---------------|------|-------------|---------------|----------------|-----------|--------------|
| | | | | | Excite | | |
| | | | | 35 | Timer In | | <u>p.255</u> |
| | | | | 37 | dis Aux Ref | | <u>p.143</u> |
| | | | | 38 | FWD JOG | | <u>p.149</u> |
| | | | | 39 | REV JOG | | <u>p.149</u> |
| | | | | 40 | Fire Mode | | <u>p.230</u> |
| | | | | 41 | EPID1 Run | | <u>p.178</u> |
| | | | | 42 | EPID1 ltermClr | | <u>p.178</u> |
| | | | | 43 | Time Event En | | <u>p.213</u> |
| | | | | 44 | Pre Heat | | <u>p.208</u> |
| | | | | 45 | Damper Open | | <u>p.187</u> |
| | | | | 46 | PumpClean | | <u>p.192</u> |
| | | | | 47 | EPID2 Run | | <u>p.178</u> |
| | | | | 48 | EPID2 ltermClr | | <u>p.178</u> |
| | | | | 49 | Sleep Wake Chg | | <u>p.178</u> |
| | | | | 50 | PID Step Ref L | | <u>p.159</u> |
| | | | | 51 | PID Step Ref M | | <u>p.159</u> |
| | | | | 52 | PID Step Ref H | | <u>p.159</u> |

| Code | Comm. Address | Name | LCD Display | Setting Range | | Initial Value | Property* | Ref. |
|------|---------------|--|----------------|------------------------|-----------------|---------------|-----------|--------------|
| | | | | | | | | |
| | | | | 53 ³⁸ | Interlock 6 | | | |
| | | | | 54 | Interlock 7 | | | |
| | | | | 55 | Interlock 8 | | | |
| 83 | 0h1553 | DI On Delay Selection | DI On DelayEn | 000 0000 ~ 111 1111 | | 111 1111 | Δ | |
| 84 | 0h1554 | DI Off Delay Selection | DI Off DelayEn | 000 0000 ~ 111 1111 | | 111 1111 | Δ | |
| 85 | 0h1555 | Multi-function input terminal On filter | DI On Delay | 0–10000 (msec) | | 10 | O | <u>p.138</u> |
| 86 | 0h1556 | Multi-function input terminal Off filter | DI Off Delay | 0–10000 (msec) | | 3 | O | <u>p.138</u> |
| 87 | 0h1557 | Multi-function input terminal selection | DI NC/NO Sel | 000 0000 – 111 1111 | | 000 0000 | Δ | <u>p.138</u> |
| | | | | 0 | A Terminal (NO) | | | |
| | | | | 1 | B Terminal (NC) | | | |
| 89 | 0h1559 | Multi-step command delay time | InCheck Time | 1–5000 (msec) | | 1 | Δ | <u>p.101</u> |
| 90 | 0h155A | Multi-function input terminal status | DI Status | 000 0000 – 111 1111 | | 000 0000 | O | <u>p.138</u> |
| | | | | 0 | Contact (Off) | | | |
| | | | | 1 | Contact | | | |

³⁸ '53(Interlock6)~55(Interlock8)' of IN-65~71 are available when Extension IO option is equipped. Refer to Extension IO option manual for more detailed information

Table of Functions

| Code | Comm. Address | Name | LCD Display | Setting Range | | Initial Value | Property* | Ref. |
|------|---------------|--------------------------------|---------------|-------------------------------------|------|---------------|-----------|----------------------|
| | | | | | (On) | | | |
| 91 | 0h155B | Pulse input amount display | TI Monitor | 0.00-50.00 (kHz) | | 0.00 | X | p.97 |
| 92 | 0h155C | TI minimum input pulse | TI Filter | 0-9999 (msec) | | 10 | O | p.97 |
| 93 | 0h155D | TI minimum input pulse | TI Pls x1 | 0 - TI Pls x2 | | 0.00 | O | p.97 |
| 94 | 0h153E | Output at TI minimum pulse (%) | TI Perc y1 | 0.00-100.00 (%) | | 0.00 | O | p.97 |
| 95 | 0h155F | TI maximum input pulse | TI Pls x2 | TI Pls x1-32.00 | | 32.00 | O | p.97 |
| 96 | 0h1560 | Output at TI maximum pulse (%) | TI Perc y2 | 0.00-100.00 (%) | | 100.00 | O | p.97 |
| 97 | 0h1561 | TI rotation direction change | TI Inverting | 0 | No | 0: No | O | p.97 |
| | | | | 1 | Yes | | | |
| 98 | 0h1562 | TI quantization level | TI Quantizing | 0.00 ³⁹ , 0.04-10.00 (%) | | 0.04 | O | p.97 |

³⁹ Quantizing is disabled if '0' is selected.

8.6 Output Terminal Block Function Group (OUT)

Data in the following table will be displayed only when the related code has been selected.

*O: Write-enabled during operation, Δ: Write-enabled when operation stops, X: Write-disabled

| Code | Comm. Address | Name | LCD Display | Parameter Setting | Initial Value | Property* | Ref. | |
|------|---------------|---------------------|-------------|--------------------|----------------|--------------|-----------------------|-----------------------|
| 00 | - | Jump Code | Jump Code | 1-99 | 30 | O | p.68 | |
| 01 | 0h1601 | Analog output1 | AO1 Mode | 0 | Frequency | 0: Frequency | O | p.291 |
| | | | | 1 | Output Current | | | |
| | | | | 2 | Output Voltage | | | |
| | | | | 3 | DCLink Voltage | | | |
| | | | | 4 | Output Power | | | |
| | | | | 7 | Target Freq | | | |
| | | | | 8 | Ramp Freq | | | |
| | | | | 9 | PID Ref Value | | | |
| | | | | 10 | PID Fdb Value | | | |
| | | | | 11 | PID Output | | | |
| | | | | 12 | Constant | | | |
| | | | | 13 | EPID1 Output | | | |
| | | | | 14 | EPID1 RefVal | | | |
| | | | | 15 | EPID1 FdbVal | | | |
| 16 | EPID2 Output | | | | | | | |
| 17 | EPID2 RefVal | | | | | | | |
| 18 | EPID2 FdbVal | | | | | | | |
| 02 | 0h1602 | Analog output1 gain | AO1 Gain | -1000.0-1000.0 (%) | 100.0 | O | p.291 | |

Table of Functions

| Code | Comm. Address | Name | LCD Display | Parameter Setting | Initial Value | Property* | Ref. | |
|------|---------------|-------------------------|--------------|---|-----------------------------------|-----------|-----------------------|-----------------------|
| 03 | 0h1603 | Analog output1 bias | AO1 Bias | -100.0-100.0 (%) | 0.0 | O | p.291 | |
| 04 | 0h1604 | Analog output1 filter | AO1 Filter | 0-10000 (msec) | 5 | O | p.291 | |
| 05 | 0h1605 | Analog constant output1 | AO1 Const % | 0.0-100.0 (%) | 0.0 | O | p.291 | |
| 06 | 0h1606 | Analog output1 monitor | AO1 Monitor | 0.0-1000.0 (%) | 0.0 | X | p.291 | |
| 07 | 0h1607 | Analog output2 | AO2 Mode | Identical to the OUT-02 AO1 Mode selected range | 0: Frequency | O | p.291 | |
| 08 | 0h1608 | Analog output2 gain | AO2 Gain | -1000.0-1000.0 (%) | 100.0 | O | p.291 | |
| 09 | 0h1609 | Analog output2 bias | AO2 Bias | -100.0-100.0 (%) | 0.0 | O | p.291 | |
| 10 | 0h160A | Analog output2 filter | AO2 Filter | 0-10000 (msec) | 5 | O | p.291 | |
| 11 | 0h160B | Analog constant output2 | AO2 Const % | 0.0-100.0 (%) | 0.0 | O | p.291 | |
| 12 | 0h160C | Analog output2 monitor | AO2 Monitor | 0.0-1000.0 (%) | 0.0 | X | p.291 | |
| 30 | 0h161E | Fault output item | Trip OutMode | bit | 000-111 | 010 | O | p.300 |
| | | | | Bit 0 | Low voltage | | | |
| | | | | Bit 1 | Any faults other than low voltage | | | |
| | | | | Bit | Automatic | | | |

| Code | Comm. Address | Name | LCD Display | Parameter Setting | Initial Value | Property* | Ref. | |
|------|---------------|-----------------------|-------------|-------------------|-----------------------|-----------|------|-----------------------|
| | | | | 2 | restart final failure | | | |
| 31 | 0h161F | Multi-function relay1 | Relay 1 | 0 | None | 23:Trip | O | p.295 |
| | | | | 1 | FDT-1 | | | |
| | | | | 2 | FDT-2 | | | |
| | | | | 3 | FDT-3 | | | |
| | | | | 4 | FDT-4 | | | |
| | | | | 5 | Over Load | | | |
| | | | | 6 | IOL | | | |
| | | | | 7 | Under Load | | | |
| | | | | 8 | Fan Warning | | | |
| | | | | 9 | Stall | | | |
| | | | | 10 | Over Voltage | | | |
| | | | | 11 | Low Voltage | | | |
| | | | | 12 | Over Heat | | | |
| | | | | 13 | Lost Command | | | |
| | | | | 14 | Run | | | |
| | | | | 15 | Stop | | | |
| | | | | 16 | Steady | | | |
| | | | | 17 | Inverter Line | | | |
| | | | | 18 | Comm Line | | | |
| | | | | 19 | Speed Search | | | |
| | | | | 20 | Ready | | | |
| | | | | 21 | MMC | | | |
| | | | | 22 | Timer Out | | | |
| | | | | 23 | Trip | | | |
| | | | | 24 | Lost Keypad | | | |
| 25 | DB Warn%ED | | | | | | | |

Table of Functions

| Code | Comm. Address | Name | LCD Display | Parameter Setting | | Initial Value | Property* | Ref. |
|------|---------------|-------------------------------|-------------|-------------------------------|----------------|---------------|-----------|-----------------------|
| | | | | 26 | On/Off Control | | | |
| | | | | 27 | Fire Mode | | | |
| | | | | 28 | Pipe Broken | | | |
| | | | | 29 | Damper Err | | | |
| | | | | 30 | Lubrication | | | |
| | | | | 31 | Pump Clean | | | |
| | | | | 32 | Level Detect | | | |
| | | | | 33 | Damper Control | | | |
| | | | | 34 | CAP.Warning | | | |
| | | | | 35 | Fan Exchange | | | |
| 32 | 0h1620 | Multi-function relay2 | Relay 2 | 36 | AUTO State | 14: RUN | O | p.295 |
| 33 | 0h1621 | Multi-function relay3 | Relay 3 | 37 | Hand State | 0: None | O | p.295 |
| 34 | 0h1622 | Multi-function relay4 | Relay 4 | 38 | TO | 0: None | O | p.295 |
| 35 | 0h1623 | Multi-function relay5 | Relay 5 | 39 | Except Date | 0: None | O | p.295 |
| 36 | 0h1624 | Multi-function 1 item | Q1 Define | 40 | KEB Operating | 0: None | O | p.295 |
| | | | | 41 | BrokenBelt | | | |
| 41 | 0h1629 | Multi-function output monitor | DO Status | DO Status (00 0000 – 11 1111) | | 00 0000 | X | p.295 |
| 50 | 0h1632 | Multi-function | DO On Delay | 0.00-100.00 (sec) | | 0.00 | O | p.301 |

| Code | Comm. Address | Name | LCD Display | Parameter Setting | Initial Value | Property* | Ref. | |
|------|---------------|---|----------------|--------------------------------------|----------------|--------------|-----------------------|-----------------------|
| | | output On delay | | | | | | |
| 51 | 0h1633 | Multi-function output Off delay | DO Off Delay | 0.00-100.00 (sec) | 0.00 | O | p.301 | |
| 52 | 0h1634 | Multi-function output contact selection | DO NC/NO Sel | Q1,Relay5-Relay1 (00 0000 – 11 1111) | | 00 0000 | Δ | p.301 |
| | | | | 0 | A contact (NO) | | | |
| | | | | 1 | B contact (NC) | | | |
| 53 | 0h1635 | Fault output On delay | TripOut OnDly | 0.00-100.00 (sec) | 0.00 | O | p.300 | |
| 54 | 0h1636 | Fault output Off delay | TripOut OffDly | 0.00-100.00 (sec) | 0.00 | O | p.300 | |
| 55 | 0h1637 | Timer On delay | TimerOn Delay | 0.00-100.00 (sec) | 0.00 | O | p.254 | |
| 56 | 0h1638 | Timer Off delay | TimerOff Delay | 0.00-100.00 (sec) | 0.00 | O | p.254 | |
| 57 | 0h1639 | Detected frequency | FDT Frequency | 0.00-Maximum frequency (Hz) | 30.00 | O | p.295 | |
| 58 | 0h163A | Detected frequency band | FDT Band | 0.00-Maximum frequency (Hz) | 10.00 | O | p.295 | |
| 61 | 0h163D | Pulse output item | TO Mode | 0 | Frequency | 0: Frequency | O | p.293 |
| | | | | 1 | Output Current | | | |
| | | | | 2 | Output Voltage | | | |
| | | | | 3 | DCLink Voltage | | | |
| | | | | 4 | Output Power | | | |

Table of Functions

| Code | Comm. Address | Name | LCD Display | Parameter Setting | Initial Value | Property* | Ref. |
|------|---------------|--------------------------------|-------------|--------------------|---------------|-----------|-----------------------|
| | | | | 7 | Target Freq | | |
| | | | | 8 | Ramp Freq | | |
| | | | | 9 | PID Ref Value | | |
| | | | | 10 | PID Fdb Value | | |
| | | | | 11 | PID Output | | |
| | | | | 12 | Constant | | |
| | | | | 13 | EPID1 Output | | |
| | | | | 14 | EPID1 RefVal | | |
| | | | | 15 | EPID1 FdbVal | | |
| | | | | 16 | EPID2 Output | | |
| | | | | 17 | EPID2 RefVal | | |
| | | | | 18 | EPID2 FdbVal | | |
| 62 | 0h163E | Pulse output gain | TO Gain | -1000.0-1000.0 (%) | 100.0 | O | p.293 |
| 63 | 0h163F | Pulse output bias | TO Bias | -100.0-100.0 (%) | 0.0 | O | p.293 |
| 64 | 0h1640 | Pulse output filter | TO Filter | 0-10000 (msec) | 5 | O | p.293 |
| 65 | 0h1641 | Pulse output constant output 2 | TO Const % | 0.0-100.0 (%) | 0.0 | O | p.293 |
| 66 | 0h1642 | Pulse output monitor | TO Monitor | 0.0-1000.0 (%) | 0.0 | X | p.293 |

8.7 Communication Function Group (COM)

Data in the following table will be displayed only when the related code has been selected.

*O: Write-enabled during operation, Δ: Write-enabled when operation stops, X: Write-disabled

| Code | Comm. Address | Name | LCD Display | Parameter Setting | Initial Value | Property* | Ref. | |
|------|---------------|------------------------------------|--------------|--------------------------|---------------|--------------|--------------|--------------|
| 00 | - | Jump Code | Jump Code | 1-99 | 20 | O | <u>p.68</u> | |
| 01 | 0h1701 | Built-in communication inverter ID | Int485 St ID | 1-MaxComID ⁴⁰ | 1 | O | <u>p.341</u> | |
| 02 | 0h1702 | Built-in communication protocol | Int485 Proto | 0 | ModBus RTU | 0: ModBusRTU | O | <u>p.341</u> |
| | | | | 2 | LS Inv 485 | | | |
| | | | | 4 | BACnet | | | |
| | | | | 5 | Metasys-N2 | | | |
| | | | | 6 ⁴¹ | ModBus Master | | | |
| 03 | 0h1703 | Built-in communication speed | Int485 BaudR | 0 | 1200 bps | 3: 9600 bps | O | <u>p.341</u> |
| | | | | 1 | 2400 bps | | | |
| | | | | 2 | 4800 bps | | | |
| | | | | 3 | 9600 bps | | | |
| | | | | 4 | 19200 bps | | | |
| | | | | 5 | 38400 bps | | | |
| | | | | 6 | 56 Kbps | | | |
| | | | | 7 | 76.8 kbps | | | |

⁴⁰ If AP1-40 is set to '4(Serve Drv)', MaxComID is '8', and if COM-02 is set to '4(BACnet), MaxComID is '127'. Otherwise MaxComID is '250'.

⁴¹ COM-02 is automatically set to '6(Modbus Master)' when AP1-40 is set to '2 or 3'. Otherwise a user can set the parameter value at user's choice.

Table of Functions

| Code | Comm. Address | Name | LCD Display | Parameter Setting | | Initial Value | Property* | Ref. |
|------------------|---------------|--------------------------------------|----------------|-------------------|--------------------------|---------------|-----------|-----------------------|
| | | | | 8 | 115.2 Kbps ⁴² | | | |
| 04 | 0h1704 | Built-in communication frame setting | Int485 Mode | 0 | D8/PN/S1 | 0: D8/PN/S1 | O | p.341 |
| | | | | 1 | D8/PN/S2 | | | |
| | | | | 2 | D8/PE/S1 | | | |
| | | | | 3 | D8/PO/S1 | | | |
| 05 | 0h1705 | Transmission delay after reception | Resp Delay | 0-1000 (msec) | | 5 | O | p.341 |
| 06 ⁴³ | 0h1706 | Communication option SW version | FBus S/W Ver | - | | - | O | - |
| 07 | 0h1707 | Communication option inverter ID | FBus ID | 0-255 | | 1 | O | - |
| 08 | 0h1708 | FIELD BUS communication speed | FBUS BaudRate | - | | 12 Mbps | O | - |
| 09 | 0h1709 | Communication option LED status | FieldBus LED | - | | - | O | - |
| 20 | 0h1714 | BACnet maximum master number | BAC Max Master | 1~127 | | 127 | O | p.377 |
| 21 | 0h1715 | BACnet | BAC | 0~4194 | | 237 | O | p.377 |

⁴²115,200 bps

⁴³COM-06~09 are displayed only when a communication option card is installed. Please refer to the communication option manual for details.

| Code | Comm. Address | Name | LCD Display | Parameter Setting | | Initial Value | Property* | Ref. |
|------|---------------|-------------------------------|----------------|-------------------|------------|---------------|-----------|-----------------------|
| | | device number1 | Dev Inst1 | | | | | |
| 22 | 0h1716 | BACnet device number2 | BAC Dev Inst2 | 0-999 | | 0 | O | p.377 |
| 23 | 0h1717 | BACnet password | BAC PassWord | 0-32767 | | 0 | O | p.377 |
| 28 | 0h171C | USB Protocol | USB Protocol | 0 | Modbus RTU | 2: LS Inv 485 | O | - |
| | | | | 2 | LS Inv 485 | | | |
| 30 | 0h171E | Number of output parameters | ParaStat usNum | 0-8 | | 3 | O | p.348 |
| 31 | 0h171F | Output Communication address1 | Para Status-1 | 0000-FFFF Hex | | 000A | O | p.348 |
| 32 | 0h1720 | Output Communication address2 | Para Status-2 | 0000-FFFF Hex | | 000E | O | p.348 |
| 33 | 0h1721 | Output Communication address3 | Para Status-3 | 0000-FFFF Hex | | 000F | O | p.348 |
| 34 | 0h1722 | Output Communication address4 | Para Status-4 | 0000-FFFF Hex | | 0000 | O | p.348 |
| 35 | 0h1723 | Output Communication address5 | Para Status-5 | 0000-FFFF Hex | | 0000 | O | p.348 |
| 36 | 0h1724 | Output Communication address6 | Para Status-6 | 0000-FFFF Hex | | 0000 | O | p.348 |
| 37 | 0h1725 | Output | Para | 0000-FFFF Hex | | 0000 | O | p.348 |

Table of Functions

| Code | Comm. Address | Name | LCD Display | Parameter Setting | Initial Value | Property* | Ref. |
|------|---------------|-------------------------------|----------------|-------------------|---------------|-----------|-----------------------|
| | | Communication address7 | Status-7 | | | | |
| 38 | 0h1726 | Output Communication address8 | Para Status-8 | 0000-FFFF Hex | 0000 | O | p.348 |
| 50 | 0h1732 | Number of input parameters | Para Ctrl Num | 0-8 | 2 | O | p.348 |
| 51 | 0h1733 | Input Communication address1 | Para Control-1 | 0000-FFFF Hex | 0005 | O | p.348 |
| 52 | 0h1734 | Input Communication address2 | Para Control-2 | 0000-FFFF Hex | 0006 | O | p.348 |
| 53 | 0h1735 | Input Communication address3 | Para Control-3 | 0000-FFFF Hex | 0000 | O | p.348 |
| 54 | 0h1736 | Input Communication address 4 | Para Control-4 | 0000-FFFF Hex | 0000 | O | p.348 |
| 55 | 0h1737 | Input Communication address 5 | Para Control-5 | 0000-FFFF Hex | 0000 | O | p.348 |
| 56 | 0h1738 | Input Communication address 6 | Para Control-6 | 0000-FFFF Hex | 0000 | O | p.348 |
| 57 | 0h1739 | Input Communication address 7 | Para Control-7 | 0000-FFFF Hex | 0000 | O | p.348 |
| 58 | 0h173A | Input | Para | 0000-FFFF Hex | 0000 | O | p.348 |

| Code | Comm. Address | Name | LCD Display | Parameter Setting | | Initial Value | Property* | Ref. |
|------|---------------|--------------------------------------|--------------|-------------------|---------------|---------------|-----------|-----------------------|
| | | Communication address 8 | Control-8 | | | | | |
| 70 | 0h1746 | Communication multi-function input 1 | Virtual DI 1 | 0 | None | 0: None | O | p.372 |
| 71 | 0h1747 | Communication multi-function input 2 | Virtual DI 2 | 1 | Fx | 0: None | O | p.372 |
| 72 | 0h1748 | Communication multi-function input 3 | Virtual DI 3 | 2 | Rx | 0: None | O | p.372 |
| 73 | 0h1749 | Communication multi-function input 4 | Virtual DI 4 | 3 | RST | 0: None | O | p.372 |
| 74 | 0h174A | Communication multi-function input 5 | Virtual DI 5 | 4 | External Trip | 0: None | O | p.372 |
| 75 | 0h174B | Communication multi-function input 6 | Virtual DI 6 | 5 | BX | 0: None | O | p.372 |
| 76 | 0h174C | Communication multi-function input 7 | Virtual DI 7 | 6 | JOG | 0: None | O | p.372 |
| 77 | 0h174D | Communi | Virtual DI | 7 | Speed-L | 0: None | O | p.372 |

Table of Functions

| Code | Comm. Address | Name | LCD Display | Parameter Setting | Initial Value | Property* | Ref. |
|------|---------------|-------------------------------|-------------|-------------------|------------------------|-----------|------|
| | | cation multi-function input 8 | 8 | 8 | Speed-M | | |
| | | | | 9 | Speed-H | | |
| | | | | 11 | XCEL-L | | |
| | | | | 12 | XCEL-M | | |
| | | | | 13 | XCEL-H | | |
| | | | | 14 | XCEL-Stop | | |
| | | | | 15 | Run Enable | | |
| | | | | 16 | 3-wire | | |
| | | | | 17 | 2 nd source | | |
| | | | | 18 | Exchange | | |
| | | | | 19 | Up | | |
| | | | | 20 | Down | | |
| | | | | 22 | U/D Clear | | |
| | | | | 23 | Analog Hold | | |
| | | | | 24 | I-Term Clear | | |
| | | | | 25 | PID Openloop | | |
| | | | | 26 | PID Gain 2 | | |
| | | | | 27 | PID Ref Change | | |
| | | | | 28 | 2 nd Motor | | |
| | | | | 29 | Interlock1 | | |
| | | 30 | Interlock2 | | | | |
| | | 31 | Interlock3 | | | | |
| | | 32 | Interlock4 | | | | |
| | | 33 | Interlock5 | | | | |
| | | 34 | Pre Excite | | | | |
| | | 35 | Timer In | | | | |

| Code | Comm. Address | Name | LCD Display | Parameter Setting | Initial Value | Property* | Ref. |
|------|---------------|---|----------------|--------------------------|----------------|-----------|--------------|
| | | | | 37 | dis Aux Ref | | |
| | | | | 38 | FWD JOG | | |
| | | | | 39 | REV JOG | | |
| | | | | 40 | Fire Mode | | |
| | | | | 41 | EPID1 Run | | |
| | | | | 42 | EPID1 ItemClr | | |
| | | | | 43 | Time Event En | | |
| | | | | 44 | Pre Heat | | |
| | | | | 45 | Damper Open | | |
| | | | | 46 | Pump Clean | | |
| | | | | 47 | EPID2 Run | | |
| | | | | 48 | EPID2 ItemClr | | |
| | | | | 49 | Sleep Wake Chg | | |
| | | | | 50 | PID Step Ref L | | |
| | | | | 51 | PID Step Ref M | | |
| | | | | 52 | PID Step Ref H | | |
| | | | | 53 ⁴⁴ | Interlock6 | | |
| | | | | 54 | Interlock7 | | |
| | | | | 55 | Interlock8 | | |
| 86 | 0h1756 | Communication multi-function input monitoring | Virt DI Status | 0000 0000 – 1111 1111 | 0000 0000 | Δ | <u>p.345</u> |

⁴⁴ '53 (Interlock6)~55(Interlock8)' of ADV-66 are available when Extension IO option is equipped. Refer to Extension IO option manual for more detailed information.

| Code | Comm. Address | Name | LCD Display | Parameter Setting | | Initial Value | Property* | Ref. |
|------|---------------|-------------------------------------|-----------------|-------------------|-----|---------------|-----------|-----------------------|
| 96 | 0h173C | Communication operation auto resume | Power On Resume | 0 | No | 0: No | Δ | p.305 |
| | | | | 1 | Yes | | | |

8.8 Advanced Function Group(PID Functions)

Data in the following table will be displayed only when the related code has been selected.

Unit MAX = PID Unit100%(PID-68)

Unit Min = (2xPID Unit 0%(PID-67)-PID Unit 100%)

Unit Default = (PID Unit 100%-PID Unit 0%)/2

Unit Band = Unit 100%-Unit 0%

***O /X: Write-enabled during operation,Δ: Writing available when operation stops**

| Code | Comm. Address | Name | LCD Display | Parameter Setting | | Initial Value | Property* | Ref. |
|------|---------------|-----------------------|---------------|-------------------|-----|---------------|-----------|-----------------------|
| 00 | - | Jump Code | Jump Code | 1-99 | | 50 | O | p.68 |
| 01 | 0h1801 | PID mode selection | PID Sel | 0 | No | 0: No | Δ | p.159 |
| | | | | 1 | Yes | | | |
| 02 | 0h1802 | E-PID selection | E-PID Sel | 0 | No | 0: No | O | p.178 |
| | | | | 1 | Yes | | | |
| 03 | 0h1803 | PID output monitor | PID Output | - | | - | X | p.159 |
| 04 | 0h1804 | PID reference monitor | PID Ref Value | - | | - | X | p.159 |
| 05 | 0h1805 | PID feedback monitor | PID Fdb Value | - | | - | X | p.159 |

| Code | Comm. Address | Name | LCD Display | Parameter Setting | | Initial Value | Property* | Ref. |
|------|---------------|--|---------------|-------------------|--------------|---------------|-----------|-----------------------|
| 06 | 0h1806 | PID error monitor value | PID Err Value | - | | - | X | p.159 |
| 10 | 0h180A | PID reference 1 source selection | PID Ref 1 Src | 0 | KeyPad | 0: Keypad | Δ | p.159 |
| | | | | 1 | V1 | | | |
| | | | | 3 | V2 | | | |
| | | | | 4 | I2 | | | |
| | | | | 5 | Int485 | | | |
| | | | | 6 | Fieldbus | | | |
| | | | | 8 | Pulse | | | |
| | | | | 9 | EPID1 Output | | | |
| | | | | 10 ⁴⁵ | V3 | | | |
| 11 | I3 | | | | | | | |
| 11 | 0h180B | PID reference 1 keypad value | PID Ref 1 Set | Unit Min–Unit Max | | Unit Default | O | p.159 |
| 12 | 0h180C | PID reference 1 auxiliary source selection | PIDRef1AuxSrc | 0 | None | 0: None | Δ | p.159 |
| | | | | 1 | V1 | | | |
| | | | | 3 | V2 | | | |
| | | | | 4 | I2 | | | |
| | | | | 6 | Pulse | | | |
| | | | | 7 | Int 485 | | | |
| | | | | 8 | FieldBus | | | |
| | | | | 10 | EPID1 Output | | | |
| | | | | 11 | E-PID Fdb | | | |

⁴⁵ '10(V3)~11(I3)' of PID-10 are available when Extension IO option is equipped. Refer to Extension IO option manual for more detailed information.

Table of Functions

| Code | Comm. Address | Name | LCD Display | Parameter Setting | Initial Value | Property* | Ref. | |
|------|----------------------|--|----------------|-------------------|----------------------------------|--------------------|-----------------------|-----------------------|
| | | | | Val | | | | |
| | | | | 12 46 V3 | | | | |
| | | | | 13 I3 | | | | |
| 13 | 0h180D | PID reference 1 auxiliary mode selection | PID Ref1AuxMod | 0 | $M+(G \cdot A)$ | 0: $M+(G \cdot A)$ | O | p.159 |
| | | | | 1 | $M \cdot (G \cdot A)$ | | | |
| | | | | 2 | $M / (G \cdot A)$ | | | |
| | | | | 3 | $M + (M \cdot (G \cdot A))$ | | | |
| | | | | 4 | $M + G^2 \cdot (A - 50)$ | | | |
| | | | | 5 | $M \cdot (G^2 \cdot (A - 50))$ | | | |
| | | | | 6 | $M / (G^2 \cdot (A - 50))$ | | | |
| | | | | 7 | $M + M \cdot G^2 \cdot (A - 50)$ | | | |
| | | | | 8 | $(M - A)^2$ | | | |
| | | | | 9 | $M^2 + A^2$ | | | |
| | | | | 10 | $\text{MAX}(M, A)$ | | | |
| | | | | 11 | $\text{MIN}(M, A)$ | | | |
| | | | | 12 | $(M + A) / 2$ | | | |
| 13 | $\text{Root}(M + A)$ | | | | | | | |
| 14 | 0h180E | PID reference auxiliary gain | PID Ref1 Aux G | -200.0~200.0 (%) | 0.0 | O | p.159 | |
| 15 | 0h180F | PID reference 2 | PID Ref 2 Src | 0 | Keypad | 0: Keypad | Δ | p.159 |
| | | | | 1 | V1 | | | |

⁴⁶ '12(V3)~13(I3)' of PID-12 are available when Extension IO option is equipped. Refer to Extension IO option manual for more detailed information.

| Code | Comm. Address | Name | LCD Display | Parameter Setting | | Initial Value | Property* | Ref. |
|------------------|---------------|--|----------------|-------------------|---------------|---------------|-----------|--------------|
| | | auxiliary source selection | | 3 | V2 | | | |
| | | | | 4 | I2 | | | |
| | | | | 5 | Int 485 | | | |
| | | | | 6 | Fieldbus | | | |
| | | | | 8 | Pulse | | | |
| | | | | 9 | E-PID Output | | | |
| | | | | 10 ⁴⁷ | V3 | | | |
| 11 | I3 | | | | | | | |
| 16 | 0h1810 | PID reference 2 keypad setting | PID Ref 2 Set | Unit Min–Unit Max | | Unit Default | O | <u>p.159</u> |
| 17 | 0h1811 | PID reference 2 auxiliary source selection | PID Ref2AuxSrc | 0 | None | 0: None | Δ | <u>p.159</u> |
| | | | | 1 | V1 | | | |
| | | | | 3 | V2 | | | |
| | | | | 4 | I2 | | | |
| | | | | 6 | Pulse | | | |
| | | | | 7 | Int 485 | | | |
| | | | | 8 | FieldBus | | | |
| | | | | 10 | EPID1 Output | | | |
| | | | | 11 | EPID1 Fdb Val | | | |
| 12 ⁴⁸ | V3 | | | | | | | |

⁴⁷ '10(V3)~11(I3)' of PID-15 are available when Extension IO option is equipped. Refer to Extension IO option manual for more detailed information.

⁴⁸ '12(V3)~13(I3)' of PID-17 are available when Extension IO option is equipped. Refer to

Table of Functions

| Code | Comm. Address | Name | LCD Display | Parameter Setting | | Initial Value | Property* | Ref. |
|------|---------------|--|----------------|-------------------|----------------|---------------|-----------|-----------------------|
| 18 | 0h1812 | PID reference 2 auxiliary mode selection | PID Ref2AuxMod | 13 | I3 | 0: M+(G*A) | O | p.159 |
| | | | | 0 | M+(G*A) | | | |
| | | | | 1 | M*(G*A) | | | |
| | | | | 2 | M/(G*A) | | | |
| | | | | 3 | M+(M*(G*A)) | | | |
| | | | | 4 | M+G*2*(A-50) | | | |
| | | | | 5 | M*(G*2*(A-50)) | | | |
| | | | | 6 | M/(G*2*(A-50)) | | | |
| | | | | 7 | M+M*G*2*(A-50) | | | |
| | | | | 8 | (M-A)^2 | | | |
| | | | | 9 | M^2+A^2 | | | |
| | | | | 10 | MAX(M,A) | | | |
| | | | | 11 | MIN(M,A) | | | |
| | | | | 12 | (M + A)/2 | | | |
| 13 | Root(M+A) | | | | | | | |
| 19 | 0h1813 | PID reference 2 auxiliary gain | PID Ref2 Aux G | -200.0–200.0 (%) | | 0.0 | O | p.159 |
| 20 | 0h1814 | PID feedback selection | PIDFdb Source | 0 | V1 | 0: V1 | Δ | p.159 |
| | | | | 2 | V2 | | | |
| | | | | 3 | I2 | | | |
| | | | | 4 | Int 485 | | | |
| | | | | 5 | FieldBus | | | |
| | | | | 7 | Pulse | | | |
| | | | | 8 | EPID1 | | | |

Extension IO option manual for more detailed information.

| Code | Comm. Address | Name | LCD Display | Parameter Setting | Initial Value | Property* | Ref. | |
|------|---------------|---|-----------------|-------------------|-----------------|---------------|------|-----------------------|
| | | | | | Output | | | |
| | | | | 9 | EPID1 Fdb Val | | | |
| | | | | 10 ⁴⁹ | V3 | | | |
| | | | | 11 | I3 | | | |
| 21 | 0h1815 | PID feedback auxiliary source selection | PID Fdb Aux Src | 0 | None | 0: None | Δ | p.159 |
| | | | | 1 | V1 | | | |
| | | | | 3 | V2 | | | |
| | | | | 4 | I2 | | | |
| | | | | 6 | Pulse | | | |
| | | | | 7 | Int 485 | | | |
| | | | | 8 | FieldBus | | | |
| | | | | 10 | EPID1 Output | | | |
| | | | | 11 | EPID1 Fdb Val | | | |
| | | | | 12 ⁵⁰ | V3 | | | |
| 22 | 0h1816 | PID feedback auxiliary mode selection | PID FdbAuxMod | 0 | $M+(G^*A)$ | 0: $M+(G^*A)$ | O | p.159 |
| | | | | 1 | $M^*(G^*A)$ | | | |
| | | | | 2 | $M/(G^*A)$ | | | |
| | | | | 3 | $M+(M^*(G^*A))$ | | | |
| | | | | 4 | $M+G^*2^*(A-$ | | | |

⁴⁹ '10(V3)~11(I3)' of PID-20 are available when Extension IO option is equipped. Refer to Extension IO option manual for more detailed information.

⁵⁰ '12(V3)~13(I3)' of PID-21 are available when Extension IO option is equipped. Refer to Extension IO option manual for more detailed information.

Table of Functions

| Code | Comm. Address | Name | LCD Display | Parameter Setting | Initial Value | Property* | Ref. |
|------|---------------|------------------------------------|---------------|--------------------|---------------|-----------|-----------------------|
| | | | | 50) | | | |
| | | | | 5 $M*(G^2*(A-50))$ | | | |
| | | | | 6 $M/(G^2*(A-50))$ | | | |
| | | | | 7 $M+M*G^2*(A-50)$ | | | |
| | | | | 8 $(M-A)^2$ | | | |
| | | | | 9 M^2+A^2 | | | |
| | | | | 10 $MAX(M,A)$ | | | |
| | | | | 11 $MIN(M,A)$ | | | |
| | | | | 12 $(M+A)/2$ | | | |
| | | | | 13 $Root(M+A)$ | | | |
| 23 | 0h1817 | PID feedback auxiliary gain | PID Fdb Aux G | -200.0–200.0 (%) | 0.0 | O | p.159 |
| 24 | 0h1818 | PID feedback band | PID Fdb Band | 0.00 – Unit Band | 0.00 | O | p.159 |
| 25 | 0h1819 | PID controller proportional gain 1 | PID P-Gain 1 | 0.00–300.00 (%) | 50.00 | O | p.159 |
| 26 | 0h181A | PID controller integral time 1 | PID I-Time 1 | 0.0–200.0 (sec) | 10.0 | O | p.159 |
| 27 | 0h181B | PID controller differential time 1 | PID D-Time 1 | 0.00–1.00 (sec) | 0.00 | O | p.159 |
| 28 | 0h181C | PID controller feed forward gain | PID FF-Gain | 0.0–1000.0 (%) | 0.0 | O | p.159 |
| 29 | 0h181D | PID output filter | PID Out LPF | 0.00–10.00 (sec) | 0.00 | O | p.159 |

| Code | Comm. Address | Name | LCD Display | Parameter Setting | Initial Value | Property* | Ref. | |
|------|---------------|------------------------------------|----------------|----------------------|-----------------|-----------------|-----------------------|-----------------------|
| 30 | 0h181E | PID output upper limit | PID Limit Hi | PID Limit Lo–100.00 | 100.00 | O | p.159 | |
| 31 | 0h181F | PID output lower limit | PID Limit Lo | -100.00–PID Limit Hi | 0.00 | O | p.159 | |
| 32 | 0h1820 | PID controller proportional gain 2 | PID P-Gain 2 | 0.00–300.00 (%) | 50.0 | O | p.159 | |
| 33 | 0h1821 | PID controller integral time 2 | PID I-Time 2 | 0.0–200.0 (sec) | 10.0 | O | p.159 | |
| 34 | 0h1822 | PID controller differential time 2 | PID D-Time 2 | 0.00–1.00 (sec) | 0.00 | O | p.159 | |
| 35 | 0h1823 | PID output mode | PID Out Mode | 0 | PID Output | 4 : PID or Main | O | p.159 |
| | | | | 1 | PID+ Main Freq | | | |
| | | | | 2 | PID+EPID1 Out | | | |
| | | | | 3 | PID+EPID1 +Main | | | |
| | | | | 4 | PID or Main | | | |
| 36 | 0h1824 | PID output inverse | PID Out Inv | 0 | No | 0: No | Δ | p.159 |
| | | | | 1 | Yes | | | |
| 37 | 0h1825 | PID output scale | PID Out Scale | 0.1–1000.0 (%) | 100.0 | Δ | p.159 | |
| 40 | 0h1828 | PID multi-step reference setting 1 | PID Step Ref 1 | Unit Min–Unit Max | Unit Default | O | p.159 | |
| 41 | 0h1829 | PID multi-step reference setting 2 | PID Step Ref 2 | Unit Min–Unit Max | Unit Default | O | p.159 | |
| 42 | 0h182A | PID multi- | PID Step | Unit Min–Unit | Unit | O | p.159 | |

Table of Functions

| Code | Comm. Address | Name | LCD Display | Parameter Setting | Initial Value | Property* | Ref. | |
|------|---------------|------------------------------------|----------------|------------------------|---------------|-----------|-----------------------|------|
| | | step reference setting 3 | Ref 3 | Max | Default | | | |
| 43 | 0h182B | PID multi-step reference setting 4 | PID Step Ref 4 | Unit Min–Unit Max | Unit Default | O | p.159 | |
| 44 | 0h182C | PID multi-step reference setting 5 | PID Step Ref 5 | Unit Min–Unit Max | Unit Default | O | p.159 | |
| 45 | 0h182D | PID multi-step reference setting 6 | PID Step Ref 6 | Unit Min–Unit Max | Unit Default | O | p.159 | |
| 46 | 0h182E | PID multi-step reference setting 7 | PID Step Ref 7 | Unit Min–Unit Max | Unit Default | O | p.159 | |
| 50 | 0h1832 | PID controller unit selection | PID Unit Sel | Refer to the Unit List | 1: % | O | p.159 | |
| | | | | 0 | | | | CUST |
| | | | | 1 | | | | % |
| | | | | 2 | | | | PSI |
| | | | | 3 | | | | °F |
| | | | | 4 | | | | °C |
| | | | | 5 | | | | inWC |
| | | | | 6 | | | | inM |
| | | | | 7 | | | | mBar |
| | | | | 8 | | | | Bar |
| | | | | 9 | | | | Pa |
| | | | | 10 | | | | kPa |
| | | | | 11 | | | | Hz |
| 12 | rpm | | | | | | | |

| Code | Comm. Address | Name | LCD Display | Parameter Setting | Initial Value | Property* | Ref. |
|------|-------------------|----------|-------------|-------------------|-------------------|-----------|--------------|
| | | | | 13 | V | | |
| | | | | 14 | A | | |
| | | | | 15 | kW | | |
| | | | | 16 | HP | | |
| | | | | 17 | mpm | | |
| | | | | 18 | ft | | |
| | | | | 19 | m/s | | |
| | | | | 20 | m ³ /s | | |
| | | | | 21 | m ³ /m | | |
| | | | | 22 | m ³ /h | | |
| | | | | 23 | l/s | | |
| | | | | 24 | l/m | | |
| | | | | 25 | l/h | | |
| | | | | 26 | kg/s | | |
| | | | | 27 | kg/m | | |
| | | | | 28 | kg/h | | |
| | | | | 29 | g/s | | |
| | | | | 30 | g/m | | |
| | | | | 31 | g/h | | |
| | | | | 32 | ft/s | | |
| 33 | f ³ /s | | | | | | |
| 34 | f ³ /m | | | | | | |
| 35 | f ³ /h | | | | | | |
| 36 | lb/s | | | | | | |
| 37 | lb/m | | | | | | |
| 38 | lb/h | | | | | | |
| 39 | ppm | | | | | | |
| 40 | pps | | | | | | |
| 51 | 0h1833 | PID unit | PID Unit | 0 x100 | 2: x 1 | O | <u>p.159</u> |

Table of Functions

| Code | Comm. Address | Name | LCD Display | Parameter Setting | | Initial Value | Property* | Ref. |
|------|---------------|---------------------------------|---------------|-------------------|------------------|---|-----------|-----------------------|
| | | scale | Scale | 1 | x10 | | | |
| | | | | 2 | x1 | | | |
| | | | | 3 | x 0.1 | | | |
| | | | | 4 | x0.01 | | | |
| 52 | 0h1834 | PID control 0% setting figure | PID Unit 0% | X100 | -30000–Unit Max | Range varies depending on PID-50 setting | O | p.159 |
| | | | | X10 | -3000.0–Unit Max | | | |
| | | | | X1 | -300.00–Unit Max | | | |
| | | | | X0.1 | -30.000–Unit Max | | | |
| | | | | X0.01 | -3.0000–Unit Max | | | |
| 53 | 0h1835 | PID control 100% setting figure | PID Unit 100% | X100 | Unit Min –30000 | Range differs depending on PID-50 setting | O | p.159 |
| | | | | X10 | Unit Min –3000.0 | | | |
| | | | | X1 | Unit Min –300.00 | | | |
| | | | | X0.1 | Unit Min –30.000 | | | |
| | | | | X0.01 | Unit Min –3.0000 | | | |

8.9 EPID Function Group (EPI)⁵¹

Data in the following table will be displayed only when the related code has been selected.

Unit MAX = EPID1 (EPID2) Unit 100%

Unit Min = (2xEPID1 (EPID2) Unit0%-EPID1 (EPID2) Unit100%)

Unit Default = (EPID1 (EPID2) Unit 100%-EPID1 (EPID2) Unit 0%)/2

***O/X : Write-enabled during operation,Δ: Writing available when operation stops**

| Code | Comm. Address | Name | LCD Display | Setting Range | | Initial Value | Property* | Ref. |
|------------------|---------------|------------------------------|---------------|-----------------|--------------|---------------|-----------|-----------------------|
| 00 | - | Jump Code | Jump Code | 1-99 | | 1 | O | p.68 |
| 01 | 0h1901 | EPID 1 Mode Selection | EPID1 Mode | 0 | None | 0: None | O | p.178 |
| | | | | 1 | Always ON | | | |
| | | | | 2 | During Run | | | |
| | | | | 3 | DI dependent | | | |
| 02 ⁵² | 0h1902 | EPID1out put monitor value | EPID1 Output | -100.00-100.00% | | 0.00 | X | p.178 |
| 03 | 0h1903 | EPID1 standard monitor | EPID1 Ref Val | - | | - | X | p.178 |
| 04 | 0h1904 | EPID1 feedback monitor value | EPID1 Fdb Val | - | | - | X | p.178 |
| 05 | 0h1905 | EPID1error monitor value | EPID1 Err Val | - | | - | X | p.178 |
| 06 | 0h1906 | EPID1 command | EPID1 Ref Src | 0 | Keypad | 0: KeyPad | Δ | p.178 |
| | | | | 1 | V1 | | | |

⁵¹ EPID Group is displayed when PID-02 code is set to 'Yes'.

⁵²EPID-02-20 are displayed when EPID-01 code is not '0 (None)'.

Table of Functions

| Code | Comm. Address | Name | LCD Display | Setting Range | | Initial Value | Property* | Ref. |
|------|---------------|---------------------------------|---------------|-------------------|----------|---------------|-----------|-----------------------|
| | | source selection | | 3 | V2 | | | |
| | | | | 4 | I2 | | | |
| | | | | 5 | Int 485 | | | |
| | | | | 6 | FieldBus | | | |
| | | | | 8 | Pulse | | | |
| | | | | 9 ⁵³ | V3 | | | |
| | | | | 10 | I3 | | | |
| 07 | 0h1907 | EPID1 keypad command value | EPID1 Ref Set | Unit Min–Unit Max | | Unit Min | O | p.178 |
| 08 | 0h1908 | EPID1 feedback source selection | EPID1 FdbSrc | 0 | V1 | 0: V1 | O | p.178 |
| | | | | 2 | V2 | | | |
| | | | | 3 | I2 | | | |
| | | | | 4 | Int485 | | | |
| | | | | 5 | FieldBus | | | |
| | | | | 7 | Pulse | | | |
| | | | | 8 ⁵⁴ | V3 | | | |
| 9 | I3 | | | | | | | |
| 09 | 0h1909 | EPID1 proportional gain | EPID1 P-Gain | 0.00–300.00 (%) | | 50.00 | O | p.178 |
| 10 | 0h190A | EPID1 integral time | EPID1 I-Time | 0.0–200.0 (sec) | | 10.0 | O | p.178 |

⁵³ '9(V3)~10(I3)' of EPID-06 are available when Extension IO option is equipped. Refer to Extension IO option manual for more detailed information.

⁵⁴ '8(V3)~9(I3)' of EPID-08 are available when Extension IO option is equipped. Refer to Extension IO option manual for more detailed information.

| Code | Comm. Address | Name | LCD Display | Setting Range | Initial Value | Property* | Ref. | |
|------|---------------|--------------------------------|----------------|---|----------------------|---|--------------|--------------|
| 11 | 0h190B | EPID1 differentiat ion time | EPID1 D-Time | 0.00–1.00 (sec) | 0.00 | O | <u>p.178</u> | |
| 12 | 0h190C | EPID1 feed- forward gain | EPID1 FF-Gain | 0.0–1000.0 (%) | 0.0 | O | <u>p.178</u> | |
| 13 | 0h190D | EPID1 output filter | EPID1 Out LPF | 0.00–10.00 (sec) | 0.00 | O | <u>p.178</u> | |
| 14 | 0h190E | EPID1 output upper limit | EPID1 Limit Hi | EPID1 Limit Lo– 100.00 | 100.00 | O | <u>p.178</u> | |
| 15 | 0h190F | EPID1 lower limit | EPID1 Limit Lo | -100.00–EPID1 Limit Hi | 0.00 | O | <u>p.178</u> | |
| 16 | 0h1910 | EPID1 output inverse | EPID1 Out Inv | 0 | No | 0: No | O | <u>p.178</u> |
| | | | | 1 | Yes | | | |
| 17 | 0h1911 | EPID1 unit | EPID1 Unit Sel | Refer to the EPID Unit details table (<u>p.178</u>) | 1: % | O | <u>p.178</u> | |
| 18 | 0h1912 | EPID1 unit scale | EPID1 Unit Scl | 0 | X100 | 2: X1 | O | <u>p.178</u> |
| | | | | 1 | X10 | | | |
| | | | | 2 | X1 | | | |
| | | | | 3 | X0.1 | | | |
| | | | | 4 | X0.01 | | | |
| 19 | 0h1913 | EPID1 unit 0% value | EPID1 Unit0% | X 100 | -30000 –Unit Max | Values vary depending on the unit setting | O | <u>p.178</u> |
| | | | | X10 | -3000.0– Unit Max | | | |
| | | | | X1 | -300.00– Unit Max | | | |
| | | | | X 0.1 | -30.000– Unit Max | | | |

Table of Functions

| Code | Comm. Address | Name | LCD Display | Setting Range | | Initial Value | Property* | Ref. |
|------------------|---------------|--|-----------------------|-----------------|----------------------|---|-----------|------------------------------|
| | | | | X 0.01 | -3.0000– Unit Max | | | |
| 20 | 0h1914 | EPID1 unit 100% value | EPID1 Unit100 % | X 100 | Unit Min– 30000 | Values vary depending on the unit setting | O | <u>p.178</u> |
| | | | | X10 | Unit Min– 3000.0 | | | |
| | | | | X1 | Unit Min– 300.00 | | | |
| | | | | X 0.1 | Unit Min– 30.000 | | | |
| | | | | X 0.01 | Unit Min– 3.0000 | | | |
| 31 | 0h191F | EPID2 Mode selection | EPID2 Mode | 0 | None | 0: None | O | <u>p.178</u> |
| | | | | 1 | Always ON | | | |
| | | | | 2 | During Run | | | |
| | | | | 3 | DI dependent | | | |
| 32 ⁵⁵ | 0h1920 | EPID2 output monitor value | EPID2 Output | -100.00–100.00% | | 0.00 | X | <u>p.178</u> |
| 33 | 0h1921 | EPID2 reference monitor value | EPID2 Ref Val | - | | - | X | <u>p.178</u> |
| 34 | 0h1922 | EPID2 feedback monitor value | EPID2 Fdb Val | - | | - | X | <u>p.178</u> |
| 35 | 0h1923 | EPID2 error monitor value | EPID2 Err Val | - | | - | X | <u>p.178</u> |

⁵⁵EPID-32–50 are displayed when EPID-31 code is not '0 (None)'.

| Code | Comm. Address | Name | LCD Display | Setting Range | | Initial Value | Property* | Ref. |
|------|---------------|---------------------------------|---------------|-------------------|----------|---------------|-----------|-----------------------|
| 36 | 0h1924 | EPID2 command source selection | EPID2 Ref Src | 0 | Keypad | 0: Keypad | Δ | p.178 |
| | | | | 1 | V1 | | | |
| | | | | 3 | V2 | | | |
| | | | | 4 | I2 | | | |
| | | | | 5 | Int 485 | | | |
| | | | | 6 | FieldBus | | | |
| | | | | 8 | Pulse | | | |
| | | | | 9 ⁵⁶ | V3 | | | |
| | | | | 10 | I3 | | | |
| 37 | 0h1925 | EPID2 keypad command value | EPID2 Ref Set | Unit Min–Unit Max | | Unit Min | O | p.178 |
| 38 | 0h1926 | EPID2 feedback source selection | EPID2 FdbSrc | 0 | V1 | 0: V1 | O | p.178 |
| | | | | 2 | V2 | | | |
| | | | | 3 | I2 | | | |
| | | | | 4 | Int 485 | | | |
| | | | | 5 | FieldBus | | | |
| | | | | 7 | Pulse | | | |
| | | | | 8 ⁵⁷ | V3 | | | |
| | | | | 9 | I3 | | | |
| 39 | 0h1927 | EPID2 proportional gain | EPID2 P-Gain | 0.00–300.00 (%) | | 50.0 | O | p.178 |

⁵⁶ '9(V3)~10(I3)' of EPID-36 are available when Extension IO option is equipped. Refer to Extension IO option manual for more detailed information.

⁵⁷ '8(V3)~9(I3)' of EPID-38 are available when Extension IO option is equipped. Refer to Extension IO option manual for more detailed information.

Table of Functions

| Code | Comm. Address | Name | LCD Display | Setting Range | Initial Value | Property* | Ref. | |
|------|---------------|----------------------------|----------------|--|------------------|---|-----------------------|-----------------------|
| 40 | 0h1928 | EPID2 integral time | EPID2 I-Time | 0.0–200.0 (sec) | 10.0 | O | p.178 | |
| 41 | 0h1929 | EPID2 differentiation time | EPID2 D-Time | 0.00–1.00 (sec) | 0.00 | O | p.178 | |
| 42 | 0h192A | EPID2 feed-forward gain | EPID2 FF-Gain | 0.0–1000.0 (%) | 0.0 | O | p.178 | |
| 43 | 0h192B | EPID2 output filter | EPID2 Out LPF | 0.00–10.00 (sec) | 0.00 | O | p.178 | |
| 44 | 0h192C | EPID2 output upper limit | EPID2 Limit Hi | EPID2 Limit Lo–100.00 | 100.00 | O | p.178 | |
| 45 | 0h192D | EPID2 output lower limit | EPID2 Limit Lo | -100.00–EPID2 Limit Hi | 0.00 | O | p.178 | |
| 46 | 0h192E | EPID2 output inverse | EPID2 Out Inv | 0 | No | 0: No | O | p.178 |
| | | | | 1 | Yes | | | |
| 47 | 0h192F | EPID2 unit | EPID2 Unit Sel | Refer to EPID Unit details table (p.178) | 0: CUST | O | p.178 | |
| 48 | 0h1930 | EPID2 unit scale | EPID2 Unit Scl | 0 | X100 | 2: X1 | O | p.178 |
| | | | | 1 | X10 | | | |
| | | | | 2 | X1 | | | |
| | | | | 3 | X0.1 | | | |
| | | | | 4 | X0.01 | | | |
| 49 | 0h1931 | EPID2 unit 0% value | EPID2 Unit0% | X100 | -30000–Unit Max | Values vary depending on the unit setting | O | p.178 |
| | | | | X10 | -3000.0–Unit Max | | | |
| | | | | X1 | -300.00–Unit Max | | | |

| Code | Comm. Address | Name | LCD Display | Setting Range | | Initial Value | Property* | Ref. |
|------|---------------|------------------------|-----------------------|---------------|----------------------|---|-----------|--------------|
| | | | | X 0.1 | -30.000– Unit Max | | | |
| | | | | X 0.01 | -3.0000– Unit Max | | | |
| 50 | 0h1932 | EPID2 unit 0% value | EPID2 Unit100 % | X 100 | Unit Min– 30000 | Values vary depending on the unit setting | O | <u>p.178</u> |
| | | | | X10 | Unit Min– 3000.0 | | | |
| | | | | X1 | Unit Min– 300.00 | | | |
| | | | | X 0.1 | Unit Min– 30.000 | | | |
| | | | | X 0.01 | Unit Min– 3.0000 | | | |

8.10 Application 1 Function Group (AP1)

Data in the following table will be displayed only when the related code has been selected.

Unit MAX = PID Unit 100%

Unit Min = (2xPID Unit 0%-PID Unit 100%)

Unit Default = (PID Unit 100%-PID Unit 0%)/2

Unit Band = Unit 100%-Unit 0%

***O/X:** Write-enabled during operation,**A:** Writing available when operation stops

| Code | Comm. Address | Name | LCD Display | Setting Range | Initial Value | Property* | Ref. |
|------|---------------|-----------------------------|-----------------|---------------------------|---------------|-----------|-----------------------|
| 00 | - | Jump Code | Jump Code | 1–99 | 20 | O | p.68 |
| 05 | 0h1A05 | Sleep boost amount | Sleep Bst Set | 0.00–Unit Max | 0.00 | O | p.174 |
| 06 | 0h1A06 | Sleep boost speed | Sleep BstFreq | 0.00, Low Freq– High Freq | 60.00 | O | p.174 |
| 07 | 0h1A07 | PID sleep mode 1 delay time | PID Sleep 1 DT | 0.0–6000.0 (sec) | 20.0 | O | p.174 |
| 08 | 0h1A08 | PID sleep mode 1 frequency | PID Sleep1Freq | 0.00, Low Freq– High Freq | 0.00 | O | p.174 |
| 09 | 0h1A09 | PID wakeup 1 delay time | PID WakeUp 1 DT | 0.0–6000.0 (sec) | 20.0 | O | p.174 |
| 10 | 0h1A0A | PID wakeup 1 value | PID WakeUp 1Dev | 0.00–Unit Band | 20.00 | O | p.174 |
| 11 | 0h1A0B | PID sleep mode 2 delay time | PID Sleep 2 DT | 0.0–6000.0 (sec) | 20.0 | O | p.174 |
| 12 | 0h1A0C | PID sleep mode 2 frequency | PID Sleep2Freq | 0.00, Low Freq– High Freq | 0.00 | O | p.174 |

| Code | Comm. Address | Name | LCD Display | Setting Range | | Initial Value | Property* | Ref. |
|------------------|---------------|--------------------------------------|-----------------|---------------------|-------------|---------------|-----------|-----------------------|
| 13 | 0h1A0D | PID wakeup 2 delay time | PID WakeUp 2 DT | 0.0–6000.0 (sec) | | 20.0 | O | p.174 |
| 14 | 0h1A0E | PID wakeup 2 value | PID WakeUp 2Dev | 0.00–Unit Band | | 20.00 | O | p.174 |
| 20 | 0h1A14 | Soft Fill function options | Soft Fill Sel | 0 | No | 0: No | O | p.173 |
| | | | | 1 | Yes | | | |
| 21 | 0h1A15 | Pre- PID operation frequency | Pre-PID Freq | Low Freq– High Freq | | 30.00 | O | p.173 |
| 22 | 0h1A16 | Pre- PID delay time | Pre-PID Delay | 0.0–600.0 (sec) | | 60.0 | O | p.173 |
| 23 | 0h1A17 | Soft Fill escape value | Soft Fill Set | Unit Min–Unit Max | | 20.00 | O | p.173 |
| 24 | 0h1A18 | Soft Fill reference increasing value | Fill Step Set | 0.00–Unit Band | | 2.00 | O | p.173 |
| 25 | 0h1A19 | Soft Fill reference increasing cycle | Fill Step Time | 0–9999 (sec) | | 20 | O | p.173 |
| 26 | 0h1A1A | Soft Fill changing amount | Fill Fdb Diff | 0.00–Unit Band | | 0.00 | O | p.173 |
| 30 | 0h1A1E | Flow Comp function options | Flow Comp Sel | 0 | No | 0: No | O | p.187 |
| | | | | 1 | Yes | | | |
| 31 | 0h1A1F | Max Comp amount | Max Comp Value | 0.00–Unit Band | | 0.00 | O | p.187 |
| 40 ⁵⁸ | 0h1A28 | MMC option selection | MMC Sel | 0 | None | 0: None | Δ | p.256 |
| | | | | 1 | Single Ctrl | | | |

⁵⁸ Set PID-1 to 'YES' to configure AP1-40.

Table of Functions

| Code | Comm. Address | Name | LCD Display | Setting Range | | Initial Value | Property* | Ref. |
|------------------|---------------|--|----------------|---------------|----------------|---------------|-----------|-----------------------|
| | | | | 2 | Multi Follower | | | |
| | | | | 3 | Multi Master | | | |
| | | | | 4 | Serve Drv | | | |
| 41 ⁵⁹ | 0h1A29 | Bypass selection | Regul Bypass | 0 | No | 0: No | Δ | p.38 |
| | | | | 1 | Yes | | | |
| 42 | 0h1A2A | Number of auxiliary motors | Num of Aux | 1–5 | | 5 | Δ | p.256 |
| 43 | 0h1A2B | Select starting auxiliary motor | Starting Aux | 1–5 | | 1 | Δ | p.256 |
| 44 | 0h1A2C | Display the number of running auxiliary motors | Aux Motor Run | - | | - | X | p.256 |
| 45 | 0h1A2D | Display auxiliary motors 1– 4 priority | Aux Priority 1 | - | | - | X | p.256 |
| 46 | 0h1A2E | Display auxiliary motors 5– 8 priority | Aux Priority 2 | - | | - | X | p.256 |
| 48 | 0h1A30 | Auxiliary motor options for inverter stop | Aux All Stop | 0 | No | 1: Yes | O | p.256 |
| | | | | 1 | Yes | | | |
| 49 | 0h1A31 | Auxiliary motor stop order. | Aux On/Off Seq | 0 | FILO | 0: FILO | Δ | p.256 |
| | | | | 1 | FIFO | | | |
| | | | | 2 | Op time Order | | | |

⁵⁹ Set AP1-40 to ' Single Ctrl ' to configure AP1-41.

| Code | Comm. Address | Name | LCD Display | Setting Range | Initial Value | Property* | Ref. | |
|------|---------------|---|----------------|--------------------|---------------|-----------------|-----------------------|-----------------------|
| 50 | 0h1A32 | Auxiliary motors pressure difference | Aux Start Diff | 0–100 (%) | 2 | O | p.256 | |
| 51 | 0h1A33 | Main motor acceleration time when the number of auxiliary motors is reduced | Aux Acc Time | 0.0–600.0 (sec) | 2.0 | O | p.256 | |
| 52 | 0h1A34 | Main motor acceleration time when the number of auxiliary motors is increased | Aux Dec Time | 0.0–600.0 (sec) | 2.0 | O | p.256 | |
| 53 | 0h1A35 | Auxiliary motors start delay time | Aux Start DT | 0.0–3600.0 (sec) | 60.0 | O | p.256 | |
| 54 | 0h1A36 | Auxiliary motors stop delay time | Aux Stop DT | 0.0–3600.0 (sec) | 60.0 | O | p.256 | |
| 55 | 0h1A37 | Auto change mode selection | Auto Ch Mode | 0 | None | 1: AUX Exchange | Δ | p.256 |
| | | | | 1 | AUX Exchange | | | |
| | | | | 2 | Main Exchange | | | |
| 56 | 0h1A38 | Auto change time | Auto Ch Time | 00: 00–99: 00 | 72: 00 | O | p.256 | |
| 57 | 0h1A39 | Auto change frequency | Auto Ch Level | Low Freq–High Freq | 20.00 | O | p.256 | |
| 58 | 0h1A3A | Auto change operation time | Auto Op Time | - | - | X | p.256 | |
| 59 | 0h1A3B | Auxiliary motor pressure difference | Aux Stop Diff | 0~100 | 2 | | | |

Table of Functions

| Code | Comm. Address | Name | LCD Display | Setting Range | Initial Value | Property* | Ref. |
|------------------|---------------|---|---------------|--------------------------------------|---------------|-----------|-----------------------|
| 60 ⁶⁰ | 0h1A3C | Target frequency of Aux motor during Multi Master | Follower Freq | Low Freq ~ High Freq | 60.00 | | |
| 61 | 0h1A3D | #1 auxiliary motor start frequency | Start Freq 1 | Freq Low Limit– Freq High limit (Hz) | 45.00 | O | p.256 |
| 62 | 0h1A3E | #2 auxiliary motor start frequency | Start Freq 2 | Low Freq– High Freq | 45.00 | O | p.256 |
| 63 | 0h1A3F | #3 auxiliary motor start frequency | Start Freq 3 | Low Freq– High Freq | 45.00 | O | p.256 |
| 64 | 0h1A40 | #4 auxiliary motor start frequency | Start Freq 4 | Low Freq– High Freq | 45.00 | O | p.256 |
| 65 | 0h1A41 | #5 auxiliary motor start frequency | Start Freq 5 | Low Freq– High Freq | 45.00 | O | p.256 |
| 66 | 0h1A42 | #6 auxiliary motor start frequency | Start Freq 6 | Low Freq– High Freq | 45.00 | O | p.256 |
| 67 | 0h1A43 | #7 auxiliary motor start frequency | Start Freq 7 | Low Freq– High Freq | 45.00 | O | p.256 |
| 68 | 0h1A44 | #8 auxiliary motor start frequency | Start Freq 8 | Low Freq– High Freq | 45.00 | O | p.256 |
| 70 | 0h1A46 | #1 auxiliary motor stop frequency | Stop Freq 1 | Low Freq– High Freq | 20.00 | O | p.256 |
| 71 | 0h1A47 | #2 auxiliary motor stop frequency | Stop Freq 2 | Low Freq– High Freq | 20.00 | O | p.256 |

⁶⁰ API-60 only appears when AP1-40 MMC Sel is set to '2' or '3'.

| Code | Comm. Address | Name | LCD Display | Setting Range | Initial Value | Property* | Ref. |
|------|---------------|---|---------------|--------------------|---------------|-----------|-----------------------|
| 72 | 0h1A48 | #3 auxiliary motor stop frequency | Stop Freq 3 | Low Freq–High Freq | 20.00 | O | p.256 |
| 73 | 0h1A49 | #4 auxiliary motor stop frequency | Stop Freq 4 | Low Freq–High Freq | 20.00 | O | p.256 |
| 74 | 0h1A4A | #5 auxiliary motor stop frequency | Stop Freq 5 | Low Freq–High Freq | 20.00 | O | p.256 |
| 75 | 0h1A4B | #6 auxiliary motor stop frequency | Stop Freq 6 | Low Freq–High Freq | 20.00 | O | p.256 |
| 76 | 0h1A4C | #7 auxiliary motor stop frequency | Stop Freq 7 | Low Freq–High Freq | 20.00 | O | p.256 |
| 77 | 0h1A4D | #8 auxiliary motor stop frequency | Stop Freq 8 | Low Freq–High Freq | 20.00 | O | p.256 |
| 80 | 0h1A50 | #1 auxiliary motor's reference compensation | Aux1 Ref Comp | 0.00–Unit Band | 0.00 | O | p.256 |
| 81 | 0h1A51 | #2 auxiliary motor reference | Aux2 Ref Comp | 0.00–Unit Band | 0.00 | O | p.256 |
| 82 | 0h1A52 | #3 auxiliary motor reference | Aux3 Ref Comp | 0.00–Unit Band | 0.00 | O | p.256 |
| 83 | 0h1A53 | #4 auxiliary motor reference | Aux4 Ref Comp | 0.00–Unit Band | 0.00 | O | p.256 |
| 84 | 0h1A54 | #5 auxiliary motor reference | Aux5 Ref Comp | 0.00–Unit Band | 0.00 | O | p.256 |
| 85 | 0h1A55 | #6 auxiliary motor reference | Aux6 Ref Comp | 0.00–Unit Band | 0.00 | O | p.256 |

Table of Functions

| Code | Comm. Address | Name | LCD Display | Setting Range | Initial Value | Property* | Ref. |
|------------------|---------------|---|-----------------|-----------------|---------------|-----------|-----------------------|
| 86 | 0h1A56 | #7 auxiliary motor reference | Aux7 Ref Comp | 0.00–Unit Band | 0.00 | O | p.256 |
| 87 | 0h1A57 | #8 auxiliary motor reference | Aux8 Ref Comp | 0.00–Unit Band | 0.00 | O | p.256 |
| 90 | 0h1A5A | Interlock selection | Interlock | 0 | NO | 0: No | p.275 |
| | | | | 1 | YES | | |
| 91 | 0h1A5B | Delay time before next motor operates when an interlock or an auto change on the main motor occurs. | Interlock DT | 0.1–360.0 (Sec) | 5.0 | O | p.275 |
| 95 ⁶¹ | 0h1A5F | Selection of Auxiliary motor to display [AP1-96] [AP1-97] | AuxRun Time Sel | 0 | Aux 1 | 0: Aux1 | O |
| | | | | 1 | Aux 2 | | |
| | | | | 2 | Aux 3 | | |
| | | | | 3 | Aux 4 | | |
| | | | | 4 | Aux 5 | | |
| | | | | 5 | Aux 6 | | |
| | | | | 6 | Aux 7 | | |
| | | | | 7 | Aux 8 | | |
| 96 | 0h1A60 | Operation time(Day) of Auxiliary motor selected in [AP1-95] | AuxRun Time Day | 0 – 65535 | 0 | O | |

⁶¹ AP1-95~98 is available when MMC and Master Follower functions are performed.

| Code | Comm. Address | Name | LCD Display | Setting Range | Initial Value | Property* | Ref. |
|------|---------------|--|-----------------|---------------|---------------|-----------|------|
| 97 | 0h1A61 | Operation time of Auxiliary motor selected in [AP1-95] (Hour:Minute) | AuxRun Time Min | 00:00 - 23:59 | 00:00 | O | |
| 98 | 0h1A62 | Deleting operation time of Auxiliary motor | AuxRun Time Clr | 0 | None | 0: None | O |
| | | | | 1 | All | | |
| | | | | 2 | Aux 1 | | |
| | | | | 3 | Aux 2 | | |
| | | | | 4 | Aux 3 | | |
| | | | | 5 | Aux 4 | | |
| | | | | 6 | Aux 5 | | |
| | | | | 7 | Aux 6 | | |
| | | | | 8 | Aux 7 | | |
| | | | | 9 | Aux 8 | | |

8.11 Application 2 Function Group (AP2)

Data In the following table will be displayed only when the related code has been selected.

*O/X: Write-enabled during operation,Δ: Writing available when operation stops

Table of Functions

| Code | Comm. Address | Name | LCD Display | Setting Range | | Initial Value | Property* | Ref. |
|------------------|---------------|-----------------------|------------------|------------------------------|--------------|---------------|-----------|-----------------------|
| 00 | - | Jump Code | Jump Code | 1–99 | | 40 | O | p.68 |
| 01 ⁶² | 0h1B01 | Load curve Tuning | Load Tune | 0 | No | No | Δ | p.199 |
| | | | | 1 | Yes | | | |
| 02 | 0h1B02 | Low Freq load curve | Load Fit Lfreq | Base Freq*15%–Load Fit HFreq | | 30.00 | Δ | p.199 |
| 03 | 0h1B03 | Low Freq current | Load Fit LCurr | 0.0–80.0 (%) | | 40.0 | Δ | p.199 |
| 04 | 0h1B04 | Low Freq power total | Load Fit LPwr | 0.0–80.0 (%) | | 30.0 | Δ | p.199 |
| 08 | 0h1B08 | High Freq load curve | Load Fit Hfreq | Load Fit LFreq–HighFreq | | 51.00 | Δ | p.199 |
| 09 | 0h1B09 | High Freq current. | Load Fit HCurr | Load Fit LCurr – 200.0 (%) | | 80.0 | Δ | p.199 |
| 10 | 0h1B0A | High Freq total power | Load Fit HPwr | Load Fit LPwr – 200.0 (%) | | 80.0 | Δ | p.199 |
| 11 | 0h1B0B | Current load curve | Load Curve Cur | - | | - | X | p.199 |
| 12 | 0h1B0C | Power load curve | Load Curve Pwr | - | | - | X | p.199 |
| 15 | 0h1B0F | Pump clean setting1 | Pump Clean Mode1 | 0 | None | 0: None | O | p.192 |
| | | | | 1 | DI Dependent | | | |
| | | | | 2 | Output Power | | | |
| | | | | 3 | Output | | | |

⁶² Set the operation mode to AUTO to configure AP2-01.

| Code | Comm. Address | Name | LCD Display | Setting Range | Initial Value | Property* | Ref. | |
|------|---------------|---|------------------|--------------------------|----------------|-----------|-----------------------|-----------------------|
| | | | | Current | | | | |
| 16 | 0h1B10 | Pump clean setting2 | Pump Clean Mode2 | 0 | None | 0: None | Δ | p.192 |
| | | | | 1 | Start | | | |
| | | | | 2 | Stop | | | |
| | | | | 3 | Start and Stop | | | |
| 17 | 0h1B11 | Pump clean load setting | PC Curve Rate | 0.1–200.0 (%) | 100.0 | O | p.192 | |
| 18 | 0h1B12 | Pump clean reference band | PC Curve Band | 0.0–100.0 (%) | 5.0 | O | p.192 | |
| 19 | 0h1B13 | Pump clean operation delay time | PC Curve DT | 0.0–6000.0 (sec) | 60.0 | O | p.192 | |
| 20 | 0h1B14 | Pump clean start delay time | PC Start DT | 0.0–6000.0 (sec) | 10.0 | O | p.192 | |
| 21 | 0h1B15 | 0 speed operating time at Fx/Rx switching | PC Step DT | 0.1–6000.0 (sec) | 5.0 | O | p.192 | |
| 22 | 0h1B16 | Pump clean Acc time | PC Acc Time | 0.0–600.0 (sec) | 10.0 | O | p.192 | |
| 23 | 0h1B17 | Pump clean Dec time | PC Dec Time | 0.0–600.0 (sec) | 10.0 | O | p.192 | |
| 24 | 0h1B18 | Forward step maintaining time | FwdSteadyTime | 0.0–600.0 (sec) | 10.0 | O | p.192 | |
| 25 | 0h1B19 | Forward step maintaining frequency | FwdSteadyFreq | 0.00, Low Freq–High Freq | 30.00 | O | p.192 | |
| 26 | 0h1B1A | Reverse step running time | Rev SteadyTime | 0.0–600.0 (sec) | 10.0 | O | p.192 | |
| 27 | 0h1B1B | Reverse step | Rev SteadyFre | 0.00, Low Freq–High Freq | 30.00 | O | p.192 | |

Table of Functions

| Code | Comm. Address | Name | LCD Display | Setting Range | Initial Value | Property* | Ref. | |
|------|---------------|--------------------------------------|-----------------|--------------------|---------------|-----------|-----------------------|-----------------------|
| | | running frequency | q | | | | | |
| 28 | 0h1B1C | Pump clean number of Fx/Rx steps | PC Num of Steps | 1–10 | 2 | O | p.192 | |
| 29 | 0h1B1D | Pump clean function cycle monitoring | Repeat Num Mon | - | - | X | p.192 | |
| 30 | 0h1B1E | Number of pump clean repetitions | Repeat Num Set | 0–10 | 2 | O | p.192 | |
| 31 | 0h1B1F | Operation after pump clean end | PC End Mode | 0 | Stop | 0:Stop | Δ | p.192 |
| | | | | 1 | Run | | | |
| 32 | 0h1B20 | Pump clean continuous limit time | PC Limit Time | 6–60 (min) | 10 | O | p.192 | |
| 33 | 0h1B21 | Pump clean continuous limit numbers | PC Limit Num | 0–10 | 3 | O | p.192 | |
| 38 | 0h1B26 | Dec Valve operation frequency | Dec Valve Freq | Low Freq–High Freq | 40.00 | O | p.198 | |
| 39 | 0h1B27 | Dev Valve Dec time | Dev Valve Time | 0.0–6000.0 (sec) | 0.0 | O | p.198 | |
| 40 | 0h1B28 | Start and End ramp settings | Start&End Ramp | 0 | No | 0: No | Δ | p.197 |
| | | | | 1 | Yes | | | |
| 41 | 0h1B29 | Start Ramp Acc time | Start Ramp Acc | 0.0–600.0 (sec) | 10.0 | O | p.197 | |
| 42 | 0h1B2A | End Ramp Dec time | End Ramp Dec | 0.0–600.0 (sec) | 10.0 | O | p.197 | |
| 45 | 0h1B2D | Damper check time | Damper check T | 0.0 – 600.0 (sec) | 5.0 | O | p.187 | |

| Code | Comm. Address | Name | LCD Display | Setting Range | Initial Value | Property* | Ref. |
|------------------|---------------|-----------------------------|----------------|-----------------|---------------|-----------|-----------------------|
| 46 | 0h1B2E | Lubrication operation time | Lub Op Time | 0.0–600.0 (sec) | 5.0 | O | p.189 |
| 48 ⁶³ | 0h1B30 | Pre heat level | Pre Heat Level | 1–100 (%) | 20 | O | p.208 |
| 49 | 0h1B31 | Pre-heat dutv | Pre-Heat Dutv | 1–100 (%) | 30 | O | p.208 |
| 50 | 0h1B32 | DC input delay time | DC Inj Delay T | 0.0–600.0 (sec) | 60.0 | O | p.208 |
| 87 | 0h1B57 | #1 Motor average power | M1 AVG PWR | 0.1–500.0 (kW) | - | O | p.191 |
| 88 | 0h1B58 | #2 Motor average power | M2 AVG PWR | 0.1–500.0 (kW) | - | O | p.191 |
| 89 | 0h1B59 | Cost per kWh | Cost per kWh | 0.0–1000.0 | 0.0 | O | p.191 |
| 90 | 0h1B5A | Saved kWh | Saved kWh | - | - | X | p.191 |
| 91 | 0h1B5B | Saved MWh | Saved MWh | - | - | X | p.191 |
| 92 | 0h1B5C | Saved Cost below 1000 unit | Saved Cost1 | - | - | X | p.191 |
| 93 | 0h1B5D | Saved Cost over 1000 unit | Saved Cost2 | - | - | X | p.191 |
| 94 | 0h1B5E | Saved CO2 conversion Factor | CO2 Factor | 0.0–5.0 | 0.0 | O | p.191 |
| 95 | 0h1B5F | Saved CO2 (Ton) | Saved CO2 – 1 | - | - | X | p.191 |
| 96 | 0h1B60 | Saved CO2 (kTon) | Saved CO2 – 2 | - | - | X | p.191 |

⁶³ AP2-48–49 are displayed when IN-65–71 is set to 'Pre-Heat'.

Table of Functions

| Code | Comm. Address | Name | LCD Display | Setting Range | | Initial Value | Property* | Ref. |
|------|---------------|--------------------|--------------|---------------|-----|---------------|-----------|--------------|
| 97 | 0h1B61 | Saved energy reset | Reset Energy | 0 | No | 0: No | Δ | <u>p.191</u> |
| | | | | 1 | Yes | | | |

8.12 Application 3 Function Group (AP3)

Data In the following table will be displayed only when the related code has been selected.

*O/X: Write-enabled during operation, Δ: Writing available when operation stops

| Code | Comm. Address | Name | LCD Display | Setting Range | Initial Value | Prop erty* | Ref. | |
|------------------|---------------|---------------------------------------|-----------------|---------------------------------------|-------------------|-----------------|-----------------------|-----------------------|
| 00 | - | Jump code | Jump Code | 1-99 | 70 | O | p.68 | |
| 01 | 0h1C01 | Current date | Now Date | 01/01/2000 ~ 12/31/2099 (Date) | 01/01/2000 | O | p.213 | |
| 02 | 0h1C02 | Current time | Now Time | 0: 00-23: 59 (min) | 0: 00 | O | p.213 | |
| 03 | 0h1C03 | Current day | Now Weekday | 0000000-1111111 (Bit) | 0000001 | O | p.213 | |
| 04 | 0h1C04 | Summer Time Start date | Summer T Start | 01/01 ~ Summer T Stop | 04/01 | O | p.213 | |
| 05 | 0h1C05 | Summer Time Finish date | Summer T Stop | Summer T Start ~12/31(Date) | 11/31 | O | p.213 | |
| 06 ⁶⁴ | 0h1C06 | Date display format | Date Format | 0 | YYYY/MM/D | MM/DD/YYYY Y | O | p.213 |
| | | | | 1 | MM/DD/YYYY | | | |
| | | | | 2 | DD/MM/YYYY | | | |
| 10 | 0h1C0A | Period connection status | Period Status | 0000 0000 0000 - 1111 1111 1111 | 0000 0000 0000 | X | p.213 | |
| 11 | 0h1C0B | Time Period1 Start time configuration | Period1 Start T | 0: 00-24: 00 (min) | 24: 00 | O | p.213 | |
| 12 | 0h1C0C | Time Period1 End time configuration | Period1 Stop T | Period1 Start T - 24: 00 (min) | 24: 00 | O | p.213 | |
| 13 | 0h1C0D | Time Period1 Day of the week | Period1 Day | 000 0000 - 111 1111 (Bit) | 000 0000 | | p.213 | |

⁶⁴ The date format can be changed according to the AP3-06 settings.

Table of Functions

| Code | Comm. Address | Name | LCD Display | Setting Range | Initial Value | Property* | Ref. |
|------|---------------|---|--------------------|-----------------------------------|---------------|-----------|-----------------------|
| | | configuration | | | | | |
| 14 | 0h1C0E | Time Period2 Start time configuration | Period2 Start T | 0: 00–24: 00 (min) | 24: 00 | O | p.213 |
| 15 | 0h1C0F | Time Period2 End time configuration | Period2 Stop T | Period2 Start T – 24: 00 (min) | 24: 00 | O | p.213 |
| 16 | 0h1C10 | Time Period2 Day of the week configuration | Period2 Day | 000 0000 – 111 1111 (Bit) | 000 0000 | O | p.213 |
| 17 | 0h1C11 | Time Period3 Start time configuration | Period3 Start T | 0: 00–24: 00 (min) | 24: 00 | O | p.213 |
| 18 | 0h1C12 | Time Period3 End time configuration | Period3 Stop T | Period3 Start T – 24: 00 (min) | 24: 00 | O | p.213 |
| 19 | 0h1C13 | Time Period3 Day of the week configuration | Period3 Day | 000 0000 – 111 1111 (Bit) | 000 0000 | O | p.213 |
| 20 | 0h1C14 | Time Period4 Start time configuration | Period4 Start T | 0: 00–24: 00 (min) | 24: 00 | O | p.213 |
| 21 | 0h1C15 | Time Period4 End time configuration | Period4 Stop T | Period4 Start T – 24: 00 (min) | 24: 00 | O | p.213 |
| 22 | 0h1C16 | Time Period Day of the week configuration | Period4 Day | 000 0000 – 111 1111 (Bit) | 000 0000 | O | p.213 |
| 30 | 0h1C1E | Except1 Date Start time configuration | Except1 Start T | 0: 00–24: 00 (min) | 24: 00 | O | p.213 |
| 31 | 0h1C1F | Except1 Date | Except1 Stop T | Except1 StartT – 24: 00 (min) | 24: 00 | O | p.213 |

| Code | Comm. Address | Name | LCD Display | Setting Range | Initial Value | Property* | Ref. |
|------|---------------|---------------------------------------|-----------------|-------------------------------|---------------|-----------|--------------|
| | | End time configuration | | | | | |
| 32 | 0h1C20 | Except1 Date configuration | Except1 Date | 01/01–12/31 (Date) | 01/01 | O | <u>p.213</u> |
| 33 | 0h1C21 | Except2 Date Start time configuration | Except2 Start T | 0: 00–24: 00 (min) | 24: 00 | O | <u>p.213</u> |
| 34 | 0h1C22 | Except2 Date Stop time configuration | Except2 Stop T | Except2 StartT – 24: 00 (min) | 24: 00 | O | <u>p.213</u> |
| 35 | 0h1C23 | Except2 Date configuration | Except2 Date | 01/01–12/31 (Date) | 01/01 | O | <u>p.213</u> |
| 36 | 0h1C24 | Except3 Date Start time configuration | Except3 Start T | 0: 00–24: 00 (min) | 24: 00 | O | <u>p.213</u> |
| 37 | 0h1C25 | Except3 Date End time configuration | Except3 Stop T | Except3 StartT – 24: 00 (min) | 24: 00 | O | <u>p.213</u> |
| 38 | 0h1C26 | Except3 Date configuration | Except3 Date | 01/01–12/31 (Date) | 01/01 | O | <u>p.213</u> |
| 39 | 0h1C27 | Except4 Date Start time configuration | Except4 Start T | 0: 00–24: 00 (min) | 24: 00 | O | <u>p.213</u> |
| 40 | 0h1C28 | Except4 Date End time configuration | Except4 Stop T | Except4 StartT – 24: 00 (min) | 24: 00 | O | <u>p.213</u> |
| 41 | 0h1C29 | Except4 Date configuration | Except4 Date | 01/01–12/31 (Date) | 01/01 | O | <u>p.213</u> |

Table of Functions

| Code | Comm. Address | Name | LCD Display | Setting Range | Initial Value | Prop erty* | Ref. |
|------|---------------|---------------------------------------|-----------------|-------------------------------|---------------|------------|-----------------------|
| 42 | 0h1C2A | Except5 Date Start time configuration | Except5 Start T | 0: 00–24: 00 (min) | 24: 00 | O | p.213 |
| 43 | 0h1C2B | Except5 Date End time | Except5 Stop T | Except5 StartT – 24: 00 (min) | 24: 00 | O | p.213 |
| 44 | 0h1C2C | Except5 Date configuration | Except5 Date | 01/01–12/31 (Date) | 01/01 | O | p.213 |
| 45 | 0h1C2D | Except6 Date Start time configuration | Except6 Start T | 0: 00–24: 00 (min) | 24: 00 | O | p.213 |
| 46 | 0h1C2E | Except6 Date End time configuration | Except6 Stop T | Except6 StartT – 24: 00 (min) | 24: 00 | O | p.213 |
| 47 | 0h1C2F | Except6 Date configuration | Except6 Date | 01/01–12/31 (Date) | 01/01 | O | p.213 |
| 48 | 0h1C30 | Except7 Date Start time configuration | Except7 Start T | 0: 00–24: 00 (min) | 24: 00 | O | p.213 |
| 49 | 0h1C31 | Except7 Date End time configuration | Except7 Stop T | Except7 StartT – 24: 00 (min) | 24: 00 | O | p.213 |
| 50 | 0h1C32 | Except7 Date configuration | Except7 Date | 01/01–12/31 (Date) | 01/01 | O | p.213 |
| 51 | 0h1C33 | Except8 Date Start time configuration | Except8 Start T | 0: 00–24: 00 (min) | 24: 00 | O | p.213 |
| 52 | 0h1C34 | Except8 Date End | Except8 Stop T | Except8 StartT – 24: 00 (min) | 24: 00 | O | p.213 |

| Code | Comm. Address | Name | LCD Display | Setting Range | Initial Value | Property* | Ref. | |
|------|---------------|-----------------------------------|-----------------|---------------------------------|----------------|-----------|-----------------------|-----------------------|
| | | time configuration | | | | | | |
| 53 | 0h1C35 | Except8 Date configuration | Except8 Date | 01/01–12/31 (Date) | 01/01 | O | p.213 | |
| 70 | 0h1C46 | Time Event function configuration | Time Event En | 0 | No | 0: NO | Δ | p.213 |
| | | | | 1 | Yes | | | |
| 71 | 0h1C47 | Time Event configuration status | T-Event Status | 0000 0000 – 1111 1111 | 0000 0000 | X | p.213 | |
| 72 | 0h1C48 | Time Event 1 connection status | T-Event1 Period | 0000 0000 0000 – 1111 1111 1111 | 0000 0000 0000 | Δ | p.213 | |
| 73 | 0h1C49 | Time Event 1 functions | T-Event1 Define | 0 | None | 0: None | Δ | p.213 |
| | | | | 1 | Fx | | | |
| | | | | 2 | Rx | | | |
| | | | | 3 | Speed-L | | | |
| | | | | 4 | Speed-M | | | |
| | | | | 5 | Speed-H | | | |
| | | | | 7 | Xcel-L | | | |
| | | | | 8 | Xcel-M | | | |
| | | | | 9 | Xcel-H | | | |
| | | | | 10 | Xcel Stop | | | |
| | | | | 11 | Run Enable | | | |
| | | | | 12 | 2nd Source | | | |
| | | | | 13 | Exchange | | | |
| | | | | 14 | Analog | | | |
| 15 | I-Term | | | | | | | |
| 16 | PID Openloop | | | | | | | |
| 17 | PID Gain 2 | | | | | | | |

Table of Functions

| Code | Comm. Address | Name | LCD Display | Setting Range | Initial Value | Property* | Ref. |
|------|---------------|---------------------------------------|-----------------|---|-------------------|-----------|-----------------------|
| | | | | 18 | PID Ref Change | | |
| | | | | 19 | 2nd Motor | | |
| | | | | 20 | Timer In | | |
| | | | | 21 | dis Aux Ref | | |
| | | | | 22 | EPID1 Run | | |
| | | | | 23 | EPID1 ITermClr | | |
| | | | | 24 | Pre Heat | | |
| | | | | 25 | EPID2 Run | | |
| | | | | 26 | EPID2 ITermClr | | |
| | | | | 27 | Sleep Wake Chg | | |
| | | | | 28 | PID Step Ref L | | |
| | | | | 29 | PID Step Ref M | | |
| | | | | 30 | PID Step Ref H | | |
| 74 | 0h1C4A | Time Event 2 connection configuration | T-Event2 Period | 0000 0000 0000 -1111 1111 1111 | 0000 0000 0000 | Δ | p.213 |
| 75 | 0h1C4B | Time Event 2 functions | T-Event2 Define | Identical to the setting range for AP3-73 | 0: None | Δ | p.213 |
| 76 | 0h1C4C | Time Event 3 connection configuration | T-Event2 Period | 0000 0000 0000 -1111 1111 1111 | 0000 0000 0000 | Δ | p.213 |
| 77 | 0h1C4D | Time Event 3 functions | T-Event3 Define | Identical to the setting range for AP3-73 | 0: None | Δ | p.213 |

| Code | Comm. Address | Name | LCD Display | Setting Range | Initial Value | Property* | Ref. |
|------|---------------|---------------------------------------|-----------------|---|-------------------|-----------|--------------|
| 78 | 0h1C4E | Time Event 4 connection configuration | T-Event4 Period | 0000 0000 0000 -1111 1111 1111 | 0000 0000 0000 | Δ | <u>p.213</u> |
| 79 | 0h1C4F | Time Event 4 functions | T-Event4 Define | Identical to the setting range for AP3-73 | 0: None | Δ | <u>p.213</u> |
| 80 | 0h1C50 | Time Event 5 connection configuration | T-Event5 Period | 0000 0000 0000 -1111 1111 1111 | 0000 0000 0000 | Δ | <u>p.213</u> |
| 81 | 0h1C51 | Time Event 5 functions | T-Event5 Define | Identical to the setting range for AP3-73 | 0: None | Δ | <u>p.213</u> |
| 82 | 0h1C52 | Time Event 6 connection configuration | T-Event6 Period | 0000 0000 0000 -1111 1111 1111 | 0000 0000 0000 | Δ | <u>p.213</u> |
| 83 | 0h1C53 | Time Event 6 functions | T-Event6 Define | Identical to the setting range for AP3-73 | 0: None | Δ | <u>p.213</u> |
| 84 | 0h1C54 | Time Event 7 connection configuration | T-Event7 Period | 0000 0000 0000 -1111 1111 1111 | 0000 0000 0000 | Δ | <u>p.213</u> |
| 85 | 0h1C55 | Time Event 7 functions | T-Event7 Define | Same setting range for AP3-73 | 0: None | Δ | <u>p.213</u> |
| 86 | 0h1C56 | Time Event 8 connection configuration | T-Event8 Period | 0000 0000 0000 -1111 1111 1111 | 0000 0000 0000 | Δ | <u>p.213</u> |
| 87 | 0h1C57 | Time Event 8 functions | T-Event8 Define | Same setting range as AP3-73 | 0: None | Δ | <u>p.213</u> |

8.13 Protection Function Group (PRT)

Data In the following table will be displayed only when the related code has been selected.

O : Write-enabled during operation, **Δ**: Write-enabled when stopped, **X**: Write disabled

| Code | Comm. Address | Name | LCD Display | Setting Range | | Initial Value | | Property* | Ref. |
|------|---------------|---------------------------------------|----------------|-----------------|--------------------------------|---------------|-----------|-----------|-----------------------|
| 00 | - | Jump Code | Jump Code | 1-99 | | 40 | | O | p.68 |
| 05 | 0h1D05 | Input/output open-phase protection | Phase Loss Chk | Bit | 00-11 | 00 | | Δ | p.318 |
| | | | | Bit 0 | Output open phase | | | | |
| | | | | Bit 1 | Input open phase | | | | |
| 06 | 0h1D06 | Input voltage range during open-phase | IPO V Band | 1-100 (V) | | 15 | | O | p.318 |
| 07 | 0h1D07 | Deceleration time at fault trip | Trip Dec Time | 0.0-600.0 (sec) | | 3.0 | 0.75~90kW | O | - |
| | | | | | | 90.0 | 110~500kW | | |
| 08 | 0h1D08 | Selection of startup on trip reset | RST Restart | Bit | 00-11 | 00 | | O | p.238 |
| | | | | Bit 0 | Fault trips other than LV trip | | | | |
| | | | | Bit 1 | LV Trip | | | | |
| 09 | 0h1D09 | Number of automatic restarts | Retry Number | 0-10 | | 0 | | O | p.238 |
| 10 | 0h1D0A | Automatic restart delay time | Retry Delay | 0.1-600.0 (sec) | | 5.0 | | O | p.238 |
| 11 | 0h1D0B | Keypad command loss operation mode | Lost KPD Mode | 0 | None | 0: None | | O | p.320 |
| | | | | 1 | Warning | | | | |
| | | | | 2 | Free-Run | | | | |

| Code | Comm. Address | Name | LCD Display | Setting Range | | Initial Value | Property* | Ref. |
|------------------|---------------|---|----------------|--------------------------|-------------|---------------|-----------|-----------------------|
| | | | | | | | | |
| | | | | 3 | Dec | | | |
| 12 | 0h1D0C | Speed command loss operation mode | Lost Cmd Mode | 0 | None | 0: None | O | p.320 |
| | | | | 1 | Free-Run | | | |
| | | | | 2 | Dec | | | |
| | | | | 3 | Hold Input | | | |
| | | | | 4 | Hold Output | | | |
| | | | | 5 | Lost | | | |
| 13 ⁶⁵ | 0h1D0D | Time to determine speed command loss | Lost Cmd Time | 0.1–120.0 (sec) | | 1.0 | O | p.320 |
| 14 | 0h1D0E | Operation frequency at speed command loss | Lost Preset F | 0.00, Low Freq–High Freq | | 0.00 | O | p.320 |
| 15 | 0h1D0F | Analog input loss decision level | AI Lost Level | 0 | Half of x1 | 0: Half of x1 | O | p.320 |
| | | | | 1 | Below x1 | | | |
| 17 | 0h1D11 | Overload warning selection | OL Warn Select | 0 | No | 0: No | O | p.309 |
| | | | | 1 | Yes | | | |
| 18 | 0h1D12 | Overload warning level | OL Warn Level | 30–OL Trip Level(%) | | 110 | O | p.309 |
| 19 | 0h1D13 | Overload warning time | OL Warn Time | 0.0–30.0 (sec) | | 10.0 | O | p.309 |
| 20 | 0h1D14 | Motion at overload trip | OL Trip Select | 0 | None | 1: Free-Run | O | p.309 |
| | | | | 1 | Free-Run | | | |
| | | | | 2 | Dec | | | |
| 21 | 0h1D15 | Overload trip level | OL Trip Level | 30–150 (%) | | 120 | O | p.309 |

⁶⁵PRT-13–15 are displayed when PRT-12 is not set to '0 (NONE)'.

Table of Functions

| Code | Comm. Address | Name | LCD Display | Setting Range | Initial Value | Property* | Ref. | |
|------|---------------|---------------------------------------|----------------|-----------------|----------------|-------------------|-----------------------|-----------------------|
| 22 | 0h1D16 | Overload trip time | OL Trip Time | 0.0–60.0 (sec) | 60.0 | O | p.309 | |
| 23 | 0h1D17 | Under load detection Source | UL Source | 0 | Output Current | 0: Output Current | Δ | p.326 |
| | | | | 1 | Output Power | | | |
| 24 | 0h1D18 | Under load detection band | UL Band | 0.0–100.0 (%) | 10.0 | Δ | p.326 | |
| 25 | 0h1D19 | Under load warning selection | UL Warn Sel | 0 | No | 0: No | O | p.326 |
| | | | | 1 | Yes | | | |
| 26 | 0h1D1A | Under load warning time | UL Warn Time | 0.0–600.0 (sec) | 10.0 | O | p.326 | |
| 27 | 0h1D1B | Under load trip selection | UL Trip Sel | 0 | None | 0: None | O | p.326 |
| | | | | 1 | Free-Run | | | |
| | | | | 2 | Dec | | | |
| 28 | 0h1D1C | Under load trip timer | UL Trip Time | 0.0–600.0 (sec) | 30.0 | O | p.326 | |
| 31 | 0h1D1F | Operation on no motor trip | No Motor Trip | 0 | None | 0: None | O | p.330 |
| | | | | 1 | Free-Run | | | |
| 32 | 0h1D20 | No motor trip current level | No Motor Level | 1–100 (%) | 5 | O | p.330 | |
| 33 | 0h1D21 | No motor detection time | No Motor Time | 0.1–10.0 (sec) | 3.0 | O | p.330 | |
| 34 | 0h1D22 | Operation at motor overheat detection | Thermal -T Sel | 0 | None | 0: None | O | p.309 |
| | | | | 1 | Free-Run | | | |
| | | | | 2 | Dec | | | |
| 35 | 0h1D23 | Thermal sensor input | Thermal In Src | 0 | Thermal In | 0: Thermal In | O | p.309 |
| | | | | 1 | V2 | | | |

| Code | Comm. Address | Name | LCD Display | Setting Range | | Initial Value | Property* | Ref. |
|------------------|---------------|--|-----------------|------------------|-------------|---------------|-----------|-----------------------|
| 36 | 0h1D24 | Thermal sensor fault level | Thermal -T Lev | 0.0–100.0 (%) | | 50.0 | O | p.309 |
| 37 | 0h1D25 | Thermal sensor fault range | Thermal -T Area | 0 | Low | 0: Low | O | p.309 |
| | | | | 1 | High | | | |
| 38 ⁶⁶ | 0h1D26 | Motor overheat detection sensor | Thermal Monitor | - | | - | X | p.309 |
| 40 | 0h1D28 | Electronic thermal prevention fault trip selection | ETH Trip Sel | 0 | None | 0: None | O | p.307 |
| | | | | 1 | Free-Run | | | |
| | | | | 2 | Dec | | | |
| 41 | 0h1D29 | Motor cooling fan type | Motor Cooling | 0 | Self-cool | 0: Self-cool | O | p.307 |
| | | | | 1 | Forced-cool | | | |
| 42 | 0h1D2A | Electronic thermal one minute rating | ETH 1 min | ETH Cont–150 (%) | | 120 | O | p.307 |
| 43 | 0h1D2B | Electronic thermal prevention continuous rating | ETH Cont | 50–120 (%) | | 100 | O | p.307 |
| 44 | 0h1D2C | Fire mode password | Fire Mode PW | 0~9999 | | 3473 | O | p.230 |
| 45 ⁶⁷ | 0h1D2D | Fire mode setting | Fire Mode Sel | 0 | None | 0: None | O | p.320 |
| | | | | 1 | Fire Mode | | | |
| | | | | 2 | Test Mode | | | |

⁶⁶PRT-38 is displayed when PRT-34 is not set to '0 (NONE)'.

⁶⁷ PRT-45 can only be set when PRT-44 is in Fire mode. To change the mode in PRT-44, create a new password for PRT-44.

Table of Functions

| Code | Comm. Address | Name | LCD Display | Setting Range | | Initial Value | Property* | Ref. |
|------------------|---------------|-----------------------------------|----------------|---|-------------------|---------------|-----------|-----------------------|
| 46 ⁶⁸ | 0h1D2E | Fire mode direction setting | Fire Mode Dir | 0 | Reverse | 1: Forward | O | p.320 |
| | | | | 1 | Forward | | | |
| 47 ⁶⁹ | 0h1D2F | Fire mode frequency setting | Fire Mode Freq | 0.00–max Freq | | 60.00 | O | p.320 |
| 48 | 0h1D30 | Number of fire mode operations | Fire Mode Cnt | - | | 0 | X | p.320 |
| 50 | 0h1D32 | Stall prevention and flux braking | Stall Prevent | bit | 0000–1111 | 0100 | Δ | p.314 |
| | | | | Bit 0 | At acceleration | | | |
| | | | | Bit 1 | At constant speed | | | |
| | | | | Bit 2 | At deceleration | | | |
| | | | | Bit 3 | Flux braking | | | |
| 51 | 0h1D33 | Stall frequency 1 | Stall Freq 1 | Start frequency- Stall frequency2 (Hz) | | 60.00 | O | p.314 |
| 52 | 0h1D34 | Stall level 1 | Stall Level 1 | 30-150 (%) | | 130 | Δ | p.314 |
| 53 | 0h1D35 | Stall frequency 2 | Stall Freq 2 | Stall frequency1- Stall frequency3 (Hz) | | 60.00 | O | p.314 |

⁶⁸PRT-46–47 are displayed when PRT-45 is not set to '0 (NONE)'.

⁶⁹ When Fire mode is set at PRT-45, PRT-46 is automatically set to forward, and the frequency set at PRT-47 cannot be edited. When PRT-45 is set to Test mode, PRT-46 and PRT-47 settings are editable.

| Code | Comm. Address | Name | LCD Display | Setting Range | Initial Value | Property* | Ref. |
|------|---------------|--------------------------------|----------------|---|---------------|-----------|-----------------------|
| 54 | 0h1D36 | Stall level 2 | Stall Level 2 | 30-150 (%) | 130 | Δ | p.314 |
| 55 | 0h1D37 | Stall frequency 3 | Stall Freq 3 | Stall frequency2- Stall frequency 4 (Hz) | 60.00 | ○ | p.314 |
| 56 | 0h1D38 | Stall level 3 | Stall Level 3 | 30-150 (%) | 130 | Δ | p.314 |
| 57 | 0h1D39 | Stall frequency 4 | Stall Freq 4 | Stall frequency3- Maximum frequency (Hz) | 60.00 | ○ | p.314 |
| 58 | 0h1D3A | Stall level 4 | Stall Level 4 | 30-150 (%) | 130 | Δ | p.314 |
| 59 | 0h1D3B | Flux braking gain | Flux Brake Kp | 0.75-90kW | 0-150 (%) | 0 | ○ |
| | | | | 110-500kW | 0-10 (%) | | |
| 60 | 0h1D3C | Pipe break detection setting | PipeBrokenSel | 0 | None | 0: None | ○ |
| | | | | 1 | Warning | | |
| | | | | 2 | Free-Run | | |
| | | | | 3 | Dec | | |
| 61 | 0h1D3D | Pipe break detection variation | PipeBroken Lev | 0.0-100.0 (%) | 97.5 | ○ | p.206 |
| 62 | 0h1D3E | Pipe break detection time | PipeBroken DT | 0.0-6000.0 (Sec) | 10.0 | ○ | p.206 |
| 66 | 0h1D42 | Braking resistor configuration | DB Warn % ED | 0-30 (%) | 0 | ○ | p.324 |
| 70 | 0h1D46 | Level detect mode selection | LDT Sel | 0 | None | 0: None | ○ |
| | | | | 1 | Warning | | |
| | | | | 2 | Free-Run | | |
| | | | | 3 | Dec | | |

Table of Functions

| Code | Comm. Address | Name | LCD Display | Setting Range | Initial Value | Property* | Ref. | |
|------|---------------|---------------------------------|--------------|----------------|-----------------|-------------------|-----------------------|-----------------------|
| 71 | 0h1D47 | Level detect range setting | LDT Area Sel | 0 | Below Level | 0: Below Level | O | p.202 |
| | | | | 1 | Above Level | | | |
| 72 | 0h1D48 | Level detect source | LDT Source | 0 | Output Current | 0: Output Current | O | p.202 |
| | | | | 1 | DC Link Voltage | | | |
| | | | | 2 | Output Voltage | | | |
| | | | | 3 | kW | | | |
| | | | | 4 | HP | | | |
| | | | | 5 | V1 | | | |
| | | | | 6 | V2 | | | |
| | | | | 7 | I2 | | | |
| | | | | 8 | PID Ref Value | | | |
| | | | | 9 | PID Fdb Value | | | |
| | | | | 10 | PID | | | |
| | | | | 11 | EPID1 Fdb Val | | | |
| | | | | 12 | EPID2 Fdb Val | | | |
| | | | | 13 | V3 | | | |
| 14 | I3 | | | | | | | |
| 73 | 0h1D49 | Level detect delay time | LDT DlyTime | 0-9999 (sec) | 2 | O | p.202 | |
| 74 | 0h1D4A | Level detect standard set value | LDT Level | Source setting | Source setting | O | p.202 | |

| Code | Comm. Address | Name | LCD Display | Setting Range | Initial Value | Property* | Ref. | |
|------------------|---------------|--|----------------|---------------------|----------------|-------------|-----------------------|-----------------------|
| 75 | 0h1D4B | Level detect band width | LDT Band width | Source setting | Source setting | O | p.202 | |
| 76 | 0h1D4C | Level detect frequency | LDT Freq | 0.00–High Freq (Hz) | 20.00 | O | p.202 | |
| 77 | 0h1D4D | Level detect trip restart time | LDT Restart DT | 0.0–3000.0 (Min) | 60.0 | O | p.202 | |
| 79 | 0h1D4F | Cooling fan fault selection | Fan Trip Mode | 0 | Trip | 1: Warning | O | p.327 |
| | | | | 1 | Warning | | | |
| 80 | 0h1D50 | Operation mode on optional card trip | Opt Trip Mode | 0 | None | 1: Free-Run | O | p.329 |
| | | | | 1 | Free-Run | | | |
| | | | | 2 | Dec | | | |
| 81 | 0h1D51 | Low voltage trip decision delay time | LVT Delay | 0.0–60.0 (sec) | 0.0 | Δ | p.327 | |
| 82 | 0h1D52 | Low voltage trip decision during operation | LV2 Trip Sel | 0 | No | 0: No | Δ | p.327 |
| | | | | 1 | Yes | | | |
| 83 | 0h1D53 | Remaining capacitor life diagnosis level | CAP.Dia gPerc | 10–100 (%) | 0 | O | p.332 | |
| 84 ⁷⁰ | - | Capacitor life diagnosis mode | CAP. Diag | 0 | None | 0: None | Δ | p.332 |
| | | | | 1 | Cap.Diag 1 | | | |
| | | | | 2 | Cap.Diag 2 | | | |
| | | | | 3 | Cap.Init | | | |
| 85 | 0h1D55 | Capacitor life diagnosis level 1 | CAP. Level1 | 50.0–95.0 (%) | 0.0 | Δ | p.332 | |

⁷⁰ PRT-84 is displayed when PRT-83 is set to more than '0(%)'. PRT- 84 can only be set in Auto-State.

Table of Functions

| Code | Comm. Address | Name | LCD Display | Setting Range | Initial Value | Property* | Ref. | |
|------------------|---------------|--|------------------|---------------|---------------|-----------|-----------------------|-----------------------|
| 86 ⁷¹ | 0h1D56 | Capacitor life diagnosis level 2 | CAP. Level2 | - | - | X | p.332 | |
| 87 | 0h1D57 | Fan accumulated operating time operation % | Fan Time Perc | - | - | X | p.334 | |
| 88 | 0h1D58 | Fan replacement alarm level | Fan Exchange | 0.0–100.0 (%) | 0.0 | O | p.334 | |
| 90 | 0h1D5A | Low battery voltage setting | Low Battery | 0 | None | 0:None | O | p.325 |
| | | | | 1 | Warning | | | |
| 91 | 0h1D5B | Setting the function of Broken belt | BrokenB elt Sel | 0 | None | 0:None | Δ | |
| | | | | 1 | Warning | | | |
| | | | | 2 | Free-Run | | | |
| 92 | 0h1D5C | Operating the frequency of Broken belt | BrokenB elt Freq | 15.00~MzxFreq | 15.00 | Δ | | |
| 93 | 0h1D5D | Motor torque current | Current Trq | - | - | X | | |
| 94 | 0h1D5E | Torque current of operating Broken belt | BrokenB elt Trq | 0.0~100.0% | 10.0 | Δ | | |
| 95 | 0 h1D5F | Delay of operating Broken belt | BrokenB elt Dly | 0~600.0[sec] | 10.0 | Δ | | |
| 96 ⁷² | 0h1D60 | LDT Auto restart count | LDT Rst Cnt | 0~6000 | 1 | Δ | P205 | |

⁷¹ PRT-86 is read only.

⁷² PRT-96-98 are displayed when PRT-70 is not set to '0 (NONE)'.

| Code | Comm. Address | Name | LCD Display | Setting Range | Initial Value | Property* | Ref. |
|------|---------------|--|---------------|---------------|---------------|-----------|--------------------|
| 97 | 0h1D61 | LDT Auto restart cycle count | LDT Rst Cnt M | - | - | X | <u>P205</u> |
| 98 | 0h1D62 | LDT Auto restart cycle Initialization time | LDT Cnt Clr T | 0~6000 | 60 | Δ | <u>P205</u> |

8.14 2nd Motor Function Group (M2)

The second motor function group is displayed when one or more of the IN-65–71 codes is set to '28 (2nd MOTOR)'. Data in the following table will be displayed only when the related code has been selected.

***O: Write-enabled during operation, Δ: Write-enabled when stopped, X: Write disabled**

| Code | Comm. Address | Name | LCD Display | Setting Range | Initial Value | Property* | Ref. | |
|------|---------------|-------------------|-------------|-----------------|-----------------|-----------|----------------------|-----------------------|
| 00 | - | Jump code | Jump Code | 1–99 | 14 | O | p.68 | |
| 04 | 0h1E04 | Acceleration time | M2-Acc Time | 0.0–600.0 (sec) | 20.0 | 0.75~90kW | O | p.241 |
| | | | | | 60.0 | 110~250kW | | |
| | | | | | 100.0 | 315~500kW | | |
| 05 | 0h1E05 | Deceleration time | M2-Dec Time | 0.0–600.0 (sec) | 30.0 | 0.75~90kW | O | p.241 |
| | | | | | 90.0 | 110~250kW | | |
| | | | | | 150.0 | 315~500kW | | |
| 06 | 0h1E06 | Motor capacity | M2-Capacity | 0 | 0.2 kW (0.3HP) | - | Δ | p.241 |
| | | | | 1 | 0.4 kW (0.5HP) | | | |
| | | | | 2 | 0.75 kW (1.0HP) | | | |
| | | | | 3 | 1.1 kW (1.5HP) | | | |
| | | | | 4 | 1.5 kW (2.0HP) | | | |
| | | | | 5 | 2.2 kW (3.0HP) | | | |

| Code | Comm. Address | Name | LCD Display | Setting Range | Initial Value | Property* | Ref. |
|------|---------------|------|-------------|---------------|---------------------|-----------|------|
| | | | | 6 | 3.0 kW (4.0HP) | | |
| | | | | 7 | 3.7 kW (5.0HP) | | |
| | | | | 8 | 4.0 kW (5.5HP) | | |
| | | | | 9 | 5.5 kW (7.5HP) | | |
| | | | | 10 | 7.5 Kw (10.0HP) | | |
| | | | | 11 | 11.0 kW (15.0HP) | | |
| | | | | 12 | 15.0 kW (20.0HP) | | |
| | | | | 13 | 18.5 kW (25.0HP) | | |
| | | | | 14 | 22.0 kW (30.0HP) | | |
| | | | | 15 | 30.0 kW (40.0HP) | | |
| | | | | 16 | 37.0 kW (50.0HP) | | |
| | | | | 17 | 45.0 kW (60.0HP) | | |
| | | | | 18 | 55.0 kW (75.0HP) | | |
| | | | | 19 | 75.0kW (100.0HP) | | |
| | | | | 20 | 90.0kW (125.0HP) | | |
| | | | | 21 | 110.0kW | | |

Table of Functions

| Code | Comm. Address | Name | LCD Display | Setting Range | Initial Value | Property* | Ref. | |
|------|---------------|-----------------------|---------------|-------------------|----------------------|-----------------------------|------|-----------------------|
| | | | | | (150.0HP) | | | |
| | | | | 22 | 132.0kW (200.0HP) | | | |
| | | | | 23 | 160.0kW (250.0HP) | | | |
| | | | | 24 | 185.0kW (300.0HP) | | | |
| | | | | 25 | 220.0kW (350.0HP) | | | |
| | | | | 26 | 250.0kW (400.0HP) | | | |
| | | | | 27 | 315.0kW (500.0HP) | | | |
| | | | | 28 | 355.0kW (550.0HP) | | | |
| | | | | 29 | 400.0kW (650.0HP) | | | |
| | | | | 30 | 500.0kW (800.0HP) | | | |
| 07 | 0h1E07 | Base frequency | M2-Base Freq | 30.00–400.00 (Hz) | | 60.00 | Δ | p.241 |
| 08 | 0h1E08 | Control mode | M2-Ctrl Mode | 0 | V/F | 0: V/F | Δ | p.241 |
| | | | | 2 | Slip Compen | | | |
| 10 | 0h1E0A | Number of motor poles | M2-Pole Num | 2–48 | | Dependent on motor settings | Δ | p.241 |
| 11 | 0h1E0B | Rated slip speed | M2-Rated Slip | 0–3000 (RPM) | | | Δ | p.241 |
| 12 | 0h1E0C | Motor rated current | M2-Rated Curr | 1.0–1000.0 (A) | | | Δ | p.241 |

| Code | Comm. Address | Name | LCD Display | Setting Range | Initial Value | Property* | Ref. | |
|------|---------------|--------------------------------------|-----------------|-------------------------------|---------------|-----------|-----------------------|-----------------------|
| 13 | 0h1E0D | Motor no-load current | M2-No-load Curr | 0.0–1000.0 (A) | | Δ | p.241 | |
| 14 | 0h1E0E | Motor rated voltage | M2-Rated Volt | 0 ⁷³ , 170–480 (V) | | Δ | p.241 | |
| 15 | 0h1E0F | Motor efficiency | M2-Efficiency | 70–100 (%) | | Δ | p.241 | |
| 17 | - | Stator resistor | M2-Rs | 0.000–9.999 (Ω) | | Δ | p.241 | |
| 18 | 0h1E12 | Leakage inductance | M2-Lsigma | 0.00–99.99 (mH) | | Δ | p.241 | |
| 25 | 0h1E19 | V/F pattern | M2-V/F Patt | 0 | Linear | 0: Linear | Δ | p.241 |
| | | | | 1 | Square | | | |
| | | | | 2 | User V/F | | | |
| 26 | 0h1E1A | Forward torque boost | M2-Fwd Boost | 0.0–15.0 (%) | 2.0 | 0.75~90kW | Δ | p.241 |
| | | | | | 1.0 | 110~500kW | | |
| 27 | 0h1E1B | Reverse torque boost | M2-Rev Boost | 0.0–15.0 (%) | 2.0 | 0.75~90kW | Δ | p.241 |
| | | | | | 1.0 | 110~500kW | | |
| 28 | 0h1E1C | Stall prevention level | M2-Stall Lev | 30–150 (%) | 130 | Δ | p.241 | |
| 29 | 0h1E1D | Electronic thermal 1 minute rating | M2-ETH 1 min | 100–150 (%) | 120 | Δ | p.241 | |
| 30 | 0h1E1E | Electronic thermal continuous rating | M2-ETH Cont | 50–120 (%) | 100 | Δ | p.241 | |

⁷³ Refer to <4.15 Output Voltage Setting>

8.15 Trip (TRIP Last-x) and Config (CNF) Mode

8.15.1 Trip Mode (TRP Last-x)

| Code | Name | LCD Display | Setting Range | Initial Value | Ref. |
|------|---|----------------|---------------|-----------------|------|
| 00 | Trip type display | Trip Name(x) | - | - | - |
| 01 | Frequency reference at trip | Output Freq | - | - | - |
| 02 | Output current at trip | Output Current | - | - | - |
| 03 | Acceleration/ Deceleration state at trip | Inverter State | - | - | - |
| 04 | DC section state | DCLink Voltage | - | - | - |
| 05 | NTC temperature | Temperature | - | - | - |
| 06 | Input terminal state | DI State | - | 0000 0000 | - |
| 07 | Output terminal state | DO State | - | 00 0000 | - |
| 08 | Trip time after Power on | Trip On Time | - | 00/00/00 00: 00 | - |
| 09 | Trip time after operation start | Trip Run Time | - | 00/00/00 00: 00 | - |
| 10 | Delete trip history | Trip Delete? | 0 | No | - |
| | | | 1 | Yes | |

8.15.2 Config Mode (CNF)

| Code | Name | LCD Display | Setting Range | Initial Value | Ref. |
|------|---------------------------|--------------|---------------|---------------|-----------------------|
| 00 | Jump code | Jump Code | 1–99 | 42 | p.68 |
| 01 | Keypad language selection | Language Sel | 0: English | 0: English | |
| 02 | LCD contrast adjustment | LCD Contrast | - | - | p.252 |

| Code | Name | LCD Display | Setting Range | | Initial Value | Ref. |
|------|---------------------------------------|----------------|---------------|----------------|------------------|-----------------------|
| 10 | Inverter S/W version | Inv S/W Ver | - | | - | p.252 |
| 11 | Keypad S/W version | KeypadS/W Ver | - | | - | p.252 |
| 12 | Keypad title version | KPD Title Ver | - | | - | p.252 |
| 20 | Display item condition display window | Anytime Para | 0 | Frequency | 0: Frequency | p.302 |
| 21 | Monitor mode display 1 | Monitor Line-1 | 1 | Speed | 0: Frequency | p.302 |
| 22 | Monitor mode display 2 | Monitor Line-2 | 2 | Output Current | 2: OutputCurrent | p.302 |
| 23 | Monitor mode display 3 | Monitor Line-3 | 3 | Output Voltage | 3: OutputVoltage | p.302 |
| | | | 4 | Output Power | | |
| | | | 5 | WHour | | |
| | | | 6 | DCLink Voltage | | |
| | | | 7 | DI Status | | |
| | | | 8 | DO Staus | | |
| | | | 9 | V1 Monitor(V) | | |
| | | | 10 | V1 Monitor(%) | | |
| | | | 13 | V2 Monitor(V) | | |
| | | | 14 | V2 Monitor(%) | | |
| | | | 15 | I2 Monitor(mA) | | |
| | | | 16 | I2 Monitor(%) | | |
| | | | 17 | PID Output | | |
| | | | 18 | PID Ref Value | | |
| | | | 19 | PID Fdb Value | | |
| 20 | EPID1 Output | | | | | |
| 21 | EPID1 Ref Val | | | | | |
| 22 | EPID1 Fdb Val | | | | | |
| 23 | EPID2 Output | | | | | |

Table of Functions

| Code | Name | LCD Display | Setting Range | | Initial Value | Ref. |
|------------------|----------------------------|----------------|---------------|---------------|---------------|--------------|
| | | | 24 | EPID2 Ref Val | | |
| | | | 25 | EPID2Fdb Val | | |
| | | | 26 | Now Date | | |
| | | | 27 | Now Time | | |
| | | | 28 | Now Weekday | | |
| 24 | Monitor mode initialize | Mon Mode Init | 0 | No | 0: No | <u>p.302</u> |
| | | | 1 | Yes | | |
| 30 ⁷⁴ | Option slot 1 type display | Option-1 Type | - | | - | <u>p.252</u> |
| 31 | Option slot 2 type display | Option-2 Type | - | | - | <u>p.252</u> |
| 32 | Option slot 3 type display | Option-3 Type | - | | - | <u>p.252</u> |
| 40 | Parameter initialization | Parameter Init | 0 | No | 0: No | <u>p.246</u> |
| | | | 1 | All Grp | | |
| | | | 2 | DRV Grp | | |
| | | | 3 | BAS Grp | | |
| | | | 4 | ADV Grp | | |
| | | | 5 | CON Grp | | |
| | | | 6 | IN Grp | | |
| | | | 7 | OUT Grp | | |
| | | | 8 | COM Grp | | |
| | | | 9 | PID Grp | | |
| | | | 10 | EPI Grp | | |
| | | | 11 | AP1 Grp | | |
| | | | 12 | AP2 Grp | | |
| | | | 13 | AP3 Grp | | |
| 14 | PRT Grp | | | | | |

⁷⁴ Please refer to the communication option manual for details.

| Code | Name | LCD Display | Setting Range | | Initial Value | Ref. |
|------|---------------------------------|-----------------|---------------|-----------------|---------------|-----------------------|
| | | | 15 | M2 Grp | | |
| 41 | Display changed Parameter | Changed Para | 0 | View All | 0: View All | p.249 |
| | | | 1 | View Changed | | |
| 42 | Multi key item | Multi Key Sel | 0 | None | 0: None | p.249 |
| | | | 1 | UserGrpSelKe | | |
| | | | 2 | Now Time | | |
| 43 | Macro function item | Macro Select | 0 | Basic | 0: Basic | p.254 |
| | | | 1 | Compressor | | |
| | | | 2 | Supply Fan | | |
| | | | 3 | Exhaust Fan | | |
| | | | 4 | Cooling Tower | | |
| | | | 5 | Circul. Pump | | |
| | | | 6 | Vacuum Pump | | |
| | | | 7 | Constant Torque | | |
| 44 | Trip history deletion | Erase All Trip | 0 | No | 0: No | p.252 |
| | | | 1 | Yes | | |
| 45 | User registration code deletion | UserGrpAllDel | 0 | No | 0: No | p.250 |
| | | | 1 | Yes | | |
| 46 | Read parameters | Parameter Read | 0 | No | 0: No | p.246 |
| | | | 1 | Yes | | |
| 47 | Write parameters | Parameter Write | 0 | No | 0: No | p.246 |
| | | | 1 | Yes | | |
| 48 | Save parameters | Parameter Save | 0 | No | 0: No | p.246 |
| | | | 1 | Yes | | |
| 50 | Hide parameter mode | View Lock Set | 0-9999 | | Un-locked | p.247 |
| 51 | Password protection (hide | View Lock Pw | 0-9999 | | Password | p.247 |

Table of Functions

| Code | Name | LCD Display | Setting Range | | Initial Value | Ref. |
|------------------|--|---------------|----------------|-----|---------------|-----------------------|
| | parameters) | | | | | |
| 52 | Lock parameter edit | Key Lock Set | 0-9999 | | Un-locked | p.247 |
| 53 | Password for locking parameter edit | Key Lock Pw | 0-9999 | | Password | p.247 |
| 60 | Additional title update | Add Title Up | 0 | No | 0: No | p.252 |
| | | | 1 | Yes | | |
| 61 | Simple parameter setting | Easy Start On | 0 | No | 1: Yes | p.251 |
| | | | 1 | Yes | | |
| 62 | Power consumption initialization | WHCount Reset | 0 | No | 0: No | p.251 |
| | | | 1 | Yes | | |
| 70 | Accumulated inverter motion time | On-time | 00000DAY 00:00 | | - | p.304 |
| 71 | Accumulated inverter operation time | Run-time | 00000DAY 00:00 | | - | p.304 |
| 72 | Accumulated inverter operation time initialization | Time Reset | 0 | No | 0: No | p.304 |
| | | | 1 | Yes | | |
| 73 ⁷⁵ | Real Time | Real Time | Date-Format | | | |
| 74 | Accumulated cooling fan operation time | Fan Time | 00000DAY 00:00 | | - | p.304 |
| 75 | Reset of accumulated cooling fan operation time | Fan Time Rst | 0 | No | 0: No | p.304 |
| | | | 1 | Yes | | |

⁷⁵ The date format can be changed according to the AP3-06 settings.

8.16 Macro Groups

The following table lists detailed parameter settings for each macro configuration.

8.16.1 Compressor (MC1) Group

| Macro Code | Code | LCD Display | Initial Value | | Macro Code | Code | LCD Display | Initial Value | |
|------------|--------|---------------|-------------------|-------|------------|--------|---------------|---------------|------|
| 0 | - | Jump Code | 1: CODE | | 1 | DRV-3 | Acc Time | 0.75~90 kW | 10.0 |
| | | | | | | | | 110~250 kW | 30.0 |
| | | | | | | | | 315~500 kW | 50.0 |
| 2 | DRV-4 | Dec Time | 0.75~90 kW | 20.0 | 3 | DRV-7 | Freq Ref Src | 1: Keypad-2 | |
| | | | 110~250 kW | 60.0 | | | | | |
| | | | 315~500 kW | 100.0 | | | | | |
| 4 | DRV-9 | Control Mode | 1: Slip Compen | | 5 | DRV-11 | JOG Frequency | 20.00 | |
| 6 | DRV-12 | JOG Acc Time | 13.0 | | 7 | DRV-13 | JOG Dec Time | 20.0 | |
| 8 | DRV-15 | Torque Boost | 1: Auto1 | | 9 | BAS-70 | Acc Time-1 | 10.0 | |
| 10 | BAS-71 | Dec Time-1 | 20.0 | | 11 | ADV-10 | Power-on Run | 1: Yes | |
| 12 | ADV-65 | U/D Save Mode | 1: Yes | | 13 | CON-4 | Carrier Freq | 3.0 | |
| 14 | CON-70 | SS Mode | 0: Flying Start-1 | | 15 | CON-77 | KEB Select | 1: Yes | |
| 16 | OUT-32 | Relay 2 | 14: Run | | 17 | PID-1 | PID Sel | 1: Yes | |
| 18 | PID-3 | PID Output | - | | 19 | PID-4 | PID Ref Value | - | |
| 20 | PID-5 | PID Fdb Value | - | | 21 | PID-10 | PID Ref 1 Src | 4: I2 | |
| 22 | PID-11 | PID Ref 1 Set | 0.5000 | | 23 | PID-25 | PID P-Gain 1 | 70.00 | |

Table of Functions

| | | | | | | | |
|----|--------|--------------|-----|----|--------|--------------|---------|
| 24 | PID-26 | PID I-Time 1 | 5.0 | 25 | PID-50 | PID Unit Sel | 5: inWC |
|----|--------|--------------|-----|----|--------|--------------|---------|

| Macro Code | Code | LCD Display | Initial Value | Macro Code | Code | LCD Display | Initial Value |
|------------|--------|----------------|----------------------------------|------------|---------|----------------|-------------------|
| 26 | PID-51 | PID Unit Scale | 4: x0.01 | 27 | AP-1 8 | PID Sleep1Freq | 5.00 |
| 28 | AP1-21 | Pre-PID Freq | 30.00 | 29 | AP1-22 | Pre-PID Delay | 120.0 |
| 30 | PRT-8 | RST Restart | 11 | 31 | PRT-9 | Retry Number | 3 |
| 32 | PRT-10 | Retry Delay | 4.0 | 33 | PRT-011 | Lost KPD Mode | 3: Dec |
| 34 | PRT-12 | Lost Cmd Mode | 2: Dec | 35 | PRT-13 | Lost Cmd Time | 4.0 |
| 36 | PRT-40 | ETH Trip Sel | 1: Free Run | 37 | PRT-42 | ETH 1 min | 120 |
| 38 | PRT-52 | Stall Level 1 | 130 | 39 | PRT-66 | DB Warn %ED | 10 |
| 40 | PRT-70 | LDT Sel | 1: Warning | 41 | PRT-72 | LDT Source | 0: Output Current |
| 42 | PRT-75 | LDT Band Width | LDT Source/10% of the Max. value | 43 | PRT-76 | LDT Freq | 20.00 |
| 44 | M2-4 | M2-Acc Time | 10.0 | 45 | M2-5 | M2-Dec Time | 20.0 |
| 46 | M2-8 | M2-Ctrl Mode | 1: Slip Compen | 47 | M2-28 | M2-Stall Lev | 125 |
| 48 | M2-29 | M2-ETH 1 min | 120 | | | | |

8.16.2 Supply Fan (MC2) Group

| Macro Code | Code | LCD Display | Initial Value | | Macro Code | Code | LCD Display | Initial Value | |
|------------|--------|----------------|-----------------|-------|------------|--------|---------------|-------------------|------|
| 0 | - | Jump Code | 1: CODE | | 1 | DRV-3 | Acc Time | 0.75~90 kW | 20.0 |
| | | | 110~250 kW | 60.0 | | | | | |
| | | | 315~500 kW | 100.0 | | | | | |
| 2 | DRV-4 | Dec Time | 0.75~90 kW | 30.0 | 3 | DRV-7 | Freq Ref Src | 1: Keypad-2 | |
| | | | 110~250 kW | 90.0 | | | | | |
| | | | 315~500 kW | 150.0 | | | | | |
| 4 | DRV-11 | JOG Frequency | 15.00 | | 5 | BAS-7 | V/F Pattern | 1: Square | |
| 6 | BAS-70 | Acc Time-1 | 20.0 | | 7 | BAS-71 | Dec Time-1 | 30.0 | |
| 8 | ADV-10 | Power-on Run | 1: Yes | | 9 | ADV-50 | E-Save Mode | 2: Auto | |
| 10 | ADV-64 | FAN Control | 2: Temp Control | | 11 | ADV-65 | U/D Save Mode | 1: Yes | |
| 12 | CON-4 | Carrier Freq | 3.0 | | 13 | CON-70 | SS Mode | 1: Flying Start-2 | |
| 14 | CON-77 | KEB Select | 1: Yes | | 15 | OUT-32 | Relay 2 | 10: Over Voltage | |
| 16 | PID-1 | PID Sel | 1: Yes | | 17 | PID-3 | PID Output | - | |
| 18 | PID-4 | PID Ref Value | - | | 19 | PID-5 | PID Fdb Value | - | |
| 20 | PID-10 | PID Ref 1 Src | 4: I2 | | 21 | PID-11 | PID Ref 1 Set | 0.5000 | |
| 22 | PID-25 | PID P-Gain 1 | 40.00 | | 23 | PID-26 | PID I-Time 1 | 20.0 | |
| 24 | PID-36 | PID Out Inv | 1: Yes | | 25 | PID-50 | PID Unit Sel | 5: inWC | |
| 26 | PID-51 | PID Unit Scale | 4: x0.01 | | 27 | AP- 21 | Pre-PID Freq | 30.00 | |
| 28 | AP1-22 | Pre-PID Delay | 120.0 | | 29 | PRT- 8 | RST Restart | 11 | |
| 30 | PRT-9 | Retry Number | 0 | | 31 | PRT-10 | Retry Delay | 20.0 | |

Table of Functions

| | | | | | | | |
|----|--------|---------------|-------------------|----|--------|----------------|-----------------------------------|
| 32 | PRT-11 | Lost KPD Mode | 3: Dec | 33 | PRT-12 | Lost Cmd Mode | 3: Hold Input |
| 34 | PRT-40 | ETH Trip Sel | 1: Free Run | 35 | PRT-42 | ETH 1 min | 120 |
| 36 | PRT-52 | Stall Level 1 | 130 | 37 | PRT-70 | LDT Sel | 1: Warning |
| 38 | PRT-72 | LDT Source | 0: Output Current | 39 | PRT-75 | LDT Band Width | LDT Source /10% of the Max. value |
| 40 | PRT-76 | LDT Freq | 10.00 | 41 | PRT-77 | LDT Restart DT | 500.0 |
| 42 | M2-25 | M2-V/F Patt | 1: Square | 43 | M2-28 | M2-Stall Lev | 110 |
| 44 | M2-29 | M2-ETH 1 min | 110 | | | | |

8.16.3 Exhaust Fan (MC3) Group

| Macro Code | Code | LCD Display | Initial Value | | Macro Code | Code | LCD Display | Initial Value | |
|------------|--------|---------------|---------------|-------|------------|--------|--------------|-----------------|-------|
| 0 | - | Jump Code | 1: CODE | | 1 | DRV-3 | Acc Time | 0.75~90 kW | 20.0 |
| | | | | | | | | 110~250 kW | 60.0 |
| | | | | | | | | 315~500 kW | 100.0 |
| 2 | DRV-4 | Dec Time | 0.75~90 kW | 30.0 | 3 | DRV-7 | Freq Ref Src | 1: Keypad-2 | |
| | | | 110~250 kW | 90.0 | | | | | |
| | | | 315~500 kW | 150.0 | | | | | |
| 4 | DRV-11 | JOG Frequency | 15.00 | | 5 | BAS-7 | V/F Pattern | 1: Square | |
| 6 | BAS-70 | Acc Time-1 | 20.0 | | 7 | BAS-71 | Dec Time-1 | 30.0 | |
| 8 | BAS-72 | Acc Time-2 | 22.5 | | 9 | BAS-73 | Dec Time-2 | 32.5 | |
| 10 | BAS-74 | Acc Time-3 | 25.0 | | 11 | BAS-75 | Dec Time-3 | 35.0 | |
| 12 | BAS-76 | Acc Time-4 | 27.5 | | 13 | BAS-77 | Dec Time-4 | 37.5 | |
| 14 | BAS-78 | Acc Time-5 | 30.0 | | 15 | BAS-80 | Acc Time-6 | 32.5 | |
| 16 | BAS-81 | Dec Time-6 | 42.5 | | 17 | BAS-82 | Acc Time-7 | 35.0 | |
| 18 | BAS-83 | Dec Time-7 | 45.0 | | 19 | ADV-10 | Power-on Run | 1: Yes | |
| 20 | ADV-50 | E-Save Mode | 2: Auto | | 21 | ADV-64 | FAN Control | 2: Temp Control | |
| 22 | ADV-65 | U/D Save Mode | 1: Yes | | 23 | CON-4 | Carrier Freq | 3.0 | |

Table of Functions

| Macro Code | Code | LCD Display | Initial Value | | Macro Code | Code | LCD Display | Initial Value | |
|------------|--------|---------------|-------------------|-------|------------|--------|--------------|-----------------|-------|
| 0 | - | Jump Code | 1: CODE | | 1 | DRV-3 | Acc Time | 0.75~90 kW | 20.0 |
| | | | | | | | | 110~250 kW | 60.0 |
| | | | | | | | | 315~500 kW | 100.0 |
| 2 | DRV-4 | Dec Time | 0.75~90 kW | 30.0 | 3 | DRV-7 | Freq Ref Src | 1: Keypad-2 | |
| | | | 110~250 kW | 90.0 | | | | | |
| | | | 315~500 kW | 150.0 | | | | | |
| 4 | DRV-11 | JOG Frequency | 15.00 | | 5 | BAS-7 | V/F Pattern | 1: Square | |
| 6 | BAS-70 | Acc Time-1 | 20.0 | | 7 | BAS-71 | Dec Time-1 | 30.0 | |
| 8 | BAS-72 | Acc Time-2 | 22.5 | | 9 | BAS-73 | Dec Time-2 | 32.5 | |
| 10 | BAS-74 | Acc Time-3 | 25.0 | | 11 | BAS-75 | Dec Time-3 | 35.0 | |
| 12 | BAS-76 | Acc Time-4 | 27.5 | | 13 | BAS-77 | Dec Time-4 | 37.5 | |
| 14 | BAS-78 | Acc Time-5 | 30.0 | | 15 | BAS-80 | Acc Time-6 | 32.5 | |
| 16 | BAS-81 | Dec Time-6 | 42.5 | | 17 | BAS-82 | Acc Time-7 | 35.0 | |
| 18 | BAS-83 | Dec Time-7 | 45.0 | | 19 | ADV-10 | Power-on Run | 1: Yes | |
| 20 | ADV-50 | E-Save Mode | 2: Auto | | 21 | ADV-64 | FAN Control | 2: Temp Control | |
| 24 | CON-70 | SS Mode | 1: Flying Start-2 | | 25 | CON-77 | KEB Select | 1: Yes | |

| Macro Code | Code | LCD Display | Initial Value | | Macro Code | Code | LCD Display | Initial Value | |
|------------|--------|---------------|------------------|-------|------------|--------|---------------|-----------------|-------|
| 0 | - | Jump Code | 1: CODE | | 1 | DRV-3 | Acc Time | 0.75~90 kW | 20.0 |
| | | | | | | | | 110~250 kW | 60.0 |
| | | | | | | | | 315~500 kW | 100.0 |
| 2 | DRV-4 | Dec Time | 0.75~90 kW | 30.0 | 3 | DRV-7 | Freq Ref Src | 1: Keypad-2 | |
| | | | 110~250 kW | 90.0 | | | | | |
| | | | 315~500 kW | 150.0 | | | | | |
| 4 | DRV-11 | JOG Frequency | 15.00 | | 5 | BAS-7 | V/F Pattern | 1: Square | |
| 6 | BAS-70 | Acc Time-1 | 20.0 | | 7 | BAS-71 | Dec Time-1 | 30.0 | |
| 8 | BAS-72 | Acc Time-2 | 22.5 | | 9 | BAS-73 | Dec Time-2 | 32.5 | |
| 10 | BAS-74 | Acc Time-3 | 25.0 | | 11 | BAS-75 | Dec Time-3 | 35.0 | |
| 12 | BAS-76 | Acc Time-4 | 27.5 | | 13 | BAS-77 | Dec Time-4 | 37.5 | |
| 14 | BAS-78 | Acc Time-5 | 30.0 | | 15 | BAS-80 | Acc Time-6 | 32.5 | |
| 16 | BAS-81 | Dec Time-6 | 42.5 | | 17 | BAS-82 | Acc Time-7 | 35.0 | |
| 18 | BAS-83 | Dec Time-7 | 45.0 | | 19 | ADV-10 | Power-on Run | 1: Yes | |
| 20 | ADV-50 | E-Save Mode | 2: Auto | | 21 | ADV-64 | FAN Control | 2: Temp Control | |
| 26 | OUT-32 | Relay 2 | 10: Over Voltage | | 27 | PID-1 | PID Sel | 1: Yes | |
| 28 | PID-3 | PID Outp | - | | 29 | PID-4 | PID Ref Value | - | |

Table of Functions

| Macro Code | Code | LCD Display | Initial Value | | Macro Code | Code | LCD Display | Initial Value | |
|------------|--------|---------------|---------------|-------|------------|--------|---------------|-----------------|-------|
| 0 | - | Jump Code | 1: CODE | | 1 | DRV-3 | Acc Time | 0.75~90 kW | 20.0 |
| | | | | | | | | 110~250 kW | 60.0 |
| | | | | | | | | 315~500 kW | 100.0 |
| 2 | DRV-4 | Dec Time | 0.75~90 kW | 30.0 | 3 | DRV-7 | Freq Ref Src | 1: Keypad-2 | |
| | | | 110~250 kW | 90.0 | | | | | |
| | | | 315~500 kW | 150.0 | | | | | |
| 4 | DRV-11 | JOG Frequency | 15.00 | | 5 | BAS-7 | V/F Pattern | 1: Square | |
| 6 | BAS-70 | Acc Time-1 | 20.0 | | 7 | BAS-71 | Dec Time-1 | 30.0 | |
| 8 | BAS-72 | Acc Time-2 | 22.5 | | 9 | BAS-73 | Dec Time-2 | 32.5 | |
| 10 | BAS-74 | Acc Time-3 | 25.0 | | 11 | BAS-75 | Dec Time-3 | 35.0 | |
| 12 | BAS-76 | Acc Time-4 | 27.5 | | 13 | BAS-77 | Dec Time-4 | 37.5 | |
| 14 | BAS-78 | Acc Time-5 | 30.0 | | 15 | BAS-80 | Acc Time-6 | 32.5 | |
| 16 | BAS-81 | Dec Time-6 | 42.5 | | 17 | BAS-82 | Acc Time-7 | 35.0 | |
| 18 | BAS-83 | Dec Time-7 | 45.0 | | 19 | ADV-10 | Power-on Run | 1: Yes | |
| 20 | ADV-50 | E-Save Mode | 2: Auto | | 21 | ADV-64 | FAN Control | 2: Temp Control | |
| | | ut | | | | | | | |
| 30 | PID-5 | PID Fdb | - | | 31 | PID-10 | PID Ref 1 Src | 4: I2 | |

| Macro Code | Code | LCD Display | Initial Value | | Macro Code | Code | LCD Display | Initial Value | |
|------------|--------|---------------|---------------|-------|------------|--------|--------------|-----------------|-------|
| 0 | - | Jump Code | 1: CODE | | 1 | DRV-3 | Acc Time | 0.75~90 kW | 20.0 |
| | | | | | | | | 110~250 kW | 60.0 |
| | | | | | | | | 315~500 kW | 100.0 |
| 2 | DRV-4 | Dec Time | 0.75~90 kW | 30.0 | 3 | DRV-7 | Freq Ref Src | 1: Keypad-2 | |
| | | | 110~250 kW | 90.0 | | | | | |
| | | | 315~500 kW | 150.0 | | | | | |
| 4 | DRV-11 | JOG Frequency | 15.00 | | 5 | BAS-7 | V/F Pattern | 1: Square | |
| 6 | BAS-70 | Acc Time-1 | 20.0 | | 7 | BAS-71 | Dec Time-1 | 30.0 | |
| 8 | BAS-72 | Acc Time-2 | 22.5 | | 9 | BAS-73 | Dec Time-2 | 32.5 | |
| 10 | BAS-74 | Acc Time-3 | 25.0 | | 11 | BAS-75 | Dec Time-3 | 35.0 | |
| 12 | BAS-76 | Acc Time-4 | 27.5 | | 13 | BAS-77 | Dec Time-4 | 37.5 | |
| 14 | BAS-78 | Acc Time-5 | 30.0 | | 15 | BAS-80 | Acc Time-6 | 32.5 | |
| 16 | BAS-81 | Dec Time-6 | 42.5 | | 17 | BAS-82 | Acc Time-7 | 35.0 | |
| 18 | BAS-83 | Dec Time-7 | 45.0 | | 19 | ADV-10 | Power-on Run | 1: Yes | |
| 20 | ADV-50 | E-Save Mode | 2: Auto | | 21 | ADV-64 | FAN Control | 2: Temp Control | |
| | | Value | | | | | | | |
| 32 | PID-11 | PID Ref 1 | 0.5000 | | 33 | PID-25 | PID P-Gain 1 | 35.00 | |

Table of Functions

| Macro Code | Code | LCD Display | Initial Value | | Macro Code | Code | LCD Display | Initial Value | |
|------------|--------|---------------|---------------|-------|------------|--------|--------------|-----------------|-------|
| 0 | - | Jump Code | 1: CODE | | 1 | DRV-3 | Acc Time | 0.75~90 kW | 20.0 |
| | | | | | | | | 110~250 kW | 60.0 |
| | | | | | | | | 315~500 kW | 100.0 |
| 2 | DRV-4 | Dec Time | 0.75~90 kW | 30.0 | 3 | DRV-7 | Freq Ref Src | 1: Keypad-2 | |
| | | | 110~250 kW | 90.0 | | | | | |
| | | | 315~500 kW | 150.0 | | | | | |
| 4 | DRV-11 | JOG Frequency | 15.00 | | 5 | BAS-7 | V/F Pattern | 1: Square | |
| 6 | BAS-70 | Acc Time-1 | 20.0 | | 7 | BAS-71 | Dec Time-1 | 30.0 | |
| 8 | BAS-72 | Acc Time-2 | 22.5 | | 9 | BAS-73 | Dec Time-2 | 32.5 | |
| 10 | BAS-74 | Acc Time-3 | 25.0 | | 11 | BAS-75 | Dec Time-3 | 35.0 | |
| 12 | BAS-76 | Acc Time-4 | 27.5 | | 13 | BAS-77 | Dec Time-4 | 37.5 | |
| 14 | BAS-78 | Acc Time-5 | 30.0 | | 15 | BAS-80 | Acc Time-6 | 32.5 | |
| 16 | BAS-81 | Dec Time-6 | 42.5 | | 17 | BAS-82 | Acc Time-7 | 35.0 | |
| 18 | BAS-83 | Dec Time-7 | 45.0 | | 19 | ADV-10 | Power-on Run | 1: Yes | |
| 20 | ADV-50 | E-Save Mode | 2: Auto | | 21 | ADV-64 | FAN Control | 2: Temp Control | |
| | | Set | | | | | | | |
| 34 | PID-26 | PID I- | 15.0 | | 35 | PID-36 | PID Out Inv | 1: Yes | |

| Macro Code | Code | LCD Display | Initial Value | | Macro Code | Code | LCD Display | Initial Value | |
|------------|--------|---------------|---------------|-------|------------|--------|--------------|-----------------|-------|
| 0 | - | Jump Code | 1: CODE | | 1 | DRV-3 | Acc Time | 0.75~90 kW | 20.0 |
| | | | | | | | | 110~250 kW | 60.0 |
| | | | | | | | | 315~500 kW | 100.0 |
| 2 | DRV-4 | Dec Time | 0.75~90 kW | 30.0 | 3 | DRV-7 | Freq Ref Src | 1: Keypad-2 | |
| | | | 110~250 kW | 90.0 | | | | | |
| | | | 315~500 kW | 150.0 | | | | | |
| 4 | DRV-11 | JOG Frequency | 15.00 | | 5 | BAS-7 | V/F Pattern | 1: Square | |
| 6 | BAS-70 | Acc Time-1 | 20.0 | | 7 | BAS-71 | Dec Time-1 | 30.0 | |
| 8 | BAS-72 | Acc Time-2 | 22.5 | | 9 | BAS-73 | Dec Time-2 | 32.5 | |
| 10 | BAS-74 | Acc Time-3 | 25.0 | | 11 | BAS-75 | Dec Time-3 | 35.0 | |
| 12 | BAS-76 | Acc Time-4 | 27.5 | | 13 | BAS-77 | Dec Time-4 | 37.5 | |
| 14 | BAS-78 | Acc Time-5 | 30.0 | | 15 | BAS-80 | Acc Time-6 | 32.5 | |
| 16 | BAS-81 | Dec Time-6 | 42.5 | | 17 | BAS-82 | Acc Time-7 | 35.0 | |
| 18 | BAS-83 | Dec Time-7 | 45.0 | | 19 | ADV-10 | Power-on Run | 1: Yes | |
| 20 | ADV-50 | E-Save Mode | 2: Auto | | 21 | ADV-64 | FAN Control | 2: Temp Control | |
| | | Time 1 | | | | | | | |

Table of Functions

| | | | | | | | |
|----|--------|---------------|-------------------|----|--------|----------------|----------------------------------|
| 36 | PID-50 | PID Unit Sel | 5: inWC | 37 | PID-51 | PID Unit Scale | 4: x0.01 |
| 38 | AP1-21 | Pre-PID Freq | 30.00 | 39 | PRT-8 | RST Restart | 11 |
| 40 | PRT-9 | Retry Number | 0 | 41 | PRT-10 | Retry Delay | 10.0 |
| 42 | PRT-11 | Lost KPD Mode | 3: Dec | 43 | PRT-12 | Lost Cmd Mode | 3: Hold Input |
| 44 | PRT-40 | ETH Trip Sel | 1:Free-Run | 45 | PRT-42 | ETH 1 min | 120 |
| 46 | PRT-52 | Stall Level 1 | 130 | 47 | PRT-70 | LDT Sel | 1: Warning |
| 48 | PRT-72 | LDT Source | 0: Output Current | 49 | PRT-75 | LDT Band Width | LDT Source/10% of the Max. value |
| 50 | PRT-76 | LDT Freq | 10.00 | 51 | PRT-77 | LDT Restart DT | 300.0 |
| 52 | M2-4 | M2-Acc Time | 10.0 | 53 | M2-5 | M2-Dec Time | 20.0 |
| 54 | M2-25 | M2-V/F Patt | 1: Square | 55 | M2-28 | M2-Stall Lev | 110 |
| 56 | M2-29 | M2-ETH 1 min | 110 | | | | |

8.16.4 Cooling Tower (MC4) Group

Table of Functions

| Macro Code | Code | LCD Display | Initial Value | | Macro Code | Code | LCD Display | Initial Value | |
|------------|---------|---------------|-------------------|-------|------------|--------|--------------|-----------------|-------|
| | | | | | | | | | |
| 0 | - | Jump Code | 1: CODE | | 1 | DRV-3 | Acc Time | 0.75~90 kW | 20.0 |
| | | | | | | | | 110~250 kW | 60.0 |
| | | | | | | | | 315~500 kW | 100.0 |
| 2 | DRV-4 | Dec Time | 0.75~90 kW | 30.0 | 3 | DRV-7 | Freq Ref Src | 1: Keypad-2 | |
| | | | 110~250 kW | 90.0 | | | | | |
| | | | 315~500 kW | 150.0 | | | | | |
| 4 | DRV-11 | JOG Frequency | 15.00 | | 5 | BAS-7 | V/F Pattern | 1: Square | |
| 6 | BAS-70 | Acc Time-1 | 20.0 | | 7 | BAS-71 | Dec Time-1 | 30.0 | |
| 8 | BAS-072 | Acc Time-2 | 22.5 | | 9 | BAS-73 | Dec Time-2 | 32.5 | |
| 10 | BAS-74 | Acc Time-3 | 25.0 | | 11 | BAS-75 | Dec Time-3 | 35.0 | |
| 12 | BAS-76 | Acc Time-4 | 27.5 | | 13 | BAS-77 | Dec Time-4 | 37.5 | |
| 14 | BAS-78 | Acc Time-5 | 30.0 | | 15 | BAS-80 | Acc Time-6 | 32.5 | |
| 16 | BAS-81 | Dec Time-6 | 42.5 | | 17 | BAS-82 | Acc Time-7 | 35.0 | |
| 18 | BAS-83 | Dec Time-7 | 45.0 | | 19 | ADV-10 | Power-on Run | 1: Yes | |
| 20 | ADV-50 | E-Save Mode | 2: Auto | | 21 | ADV-64 | FAN Control | 2: Temp Control | |
| 22 | ADV-65 | U/D Save Mode | 1: Yes | | 23 | CON-4 | Carrier Freq | 3.0 | |
| 24 | CON-70 | SS Mode | 1: Flying Start-2 | | 25 | CON-77 | KEB Select | 1: Yes | |

| | | | | | | | |
|----|--------|---------|------------------|----|-------|---------|--------|
| 26 | OUT-32 | Relay 2 | 10: Over Voltage | 27 | PID-1 | PID Sel | 1: Yes |
|----|--------|---------|------------------|----|-------|---------|--------|

| | | | | | | | |
|----|--------|----------------|----------------------------------|----|--------|----------------|-------------------|
| 28 | PID-3 | PID Output | - | 29 | PID-4 | PID Ref Value | - |
| 30 | PID -5 | PID Fdb Value | - | 31 | PID-10 | PID Ref 1 Src | 4: I2 |
| 32 | PID-11 | PID Ref 1 Set | 50.00 | 33 | PID-25 | PID P-Gain 1 | 40.00 |
| 34 | PID-26 | PID I-Time 1 | 15.0 | 35 | PID-36 | PID Out Inv | 1: Yes |
| 36 | PID-50 | PID Unit Sel | 3: °F | 37 | PID-51 | PID Unit Scale | 2: x1 |
| 38 | AP1-21 | Pre-PID Freq | 30.00 | 39 | AP1-22 | Pre-PID Delay | 120.0 |
| 40 | PRT-8 | RST Restart | 11 | 41 | PRT-9 | Retry Number | 0 |
| 42 | PRT-10 | Retry Delay | 10.0 | 43 | PRT-11 | Lost KPD Mode | 3: Dec |
| 44 | PRT-12 | Lost Cmd Mode | 3: Hold Input | 45 | PRT-40 | ETH Trip Sel | 1: Free Run |
| 46 | PRT-42 | ETH 1 min | 120 | 47 | PRT-52 | Stall Level 1 | 130 |
| 48 | PRT-70 | LDT Sel | 1: Warning | 49 | PRT-72 | LDT Source | 0: Output Current |
| 50 | PRT-75 | LDT Band Width | LDT Source/10% of the Max. value | 51 | PRT-76 | LDT Freq | 10.00 |
| 52 | PRT 77 | LDT Restart DT | 300.0 | 53 | M2-25 | M2-V/F Patt | 1: Square |
| 54 | M2 28 | M2-Stall Lev | 110 | 55 | M2-29 | M2-ETH 1 min | 110 |

8.16.5 Circulation Pump (MC5) Group

Table of Functions

| Macro Code | Code | LCD Display | Initial Value | | Macro Code | Code | LCD Display | Initial Value | |
|------------|--------|--------------|----------------|-------|------------|--------|---------------|---------------|-------|
| 0 | - | Jump Code | 1:CODE | | 1 | DRV-3 | Acc Time | 0.75~90 kW | 30.0 |
| | | | | | | | | 110~250 kW | 90.0 |
| | | | | | | | | 315~500 kW | 150.0 |
| 2 | DRV-4 | Dec Time | 0.75~90 kW | 50.0 | 3 | DRV-7 | Freq Ref Src | 1: Keypad-2 | |
| | | | 110~250 kW | 150.0 | | | | | |
| | | | 315~500 kW | 250.0 | | | | | |
| 4 | DRV-9 | Control Mode | 1: Slip Compen | | 5 | DRV-11 | JOG Frequency | 15.00 | |
| 6 | DRV-12 | JOG Acc Time | 30.0 | | 7 | DRV-13 | JOG Dec Time | 50.0 | |
| 8 | DRV-15 | Torque Boost | 1: Auto1 | | 9 | BAS-7 | V/F Pattern | 1: Square | |
| 10 | BAS-70 | Acc Time-1 | 30.0 | | 11 | BAS-71 | Dec Time-1 | 50.0 | |
| 12 | BAS-72 | Acc Time-2 | 32.0 | | 13 | BAS-73 | Dec Time-2 | 52.0 | |
| 14 | BAS-74 | Acc Time-3 | 34.0 | | 15 | BAS-75 | Dec Time-3 | 54.0 | |
| 16 | BAS-76 | Acc Time-4 | 36.0 | | 17 | BAS-77 | Dec Time-4 | 56.0 | |
| 18 | BAS-78 | Acc Time-5 | 38.0 | | 19 | BAS-79 | Dec Time-5 | 58.0 | |
| 20 | BAS-80 | Acc Time-6 | 40.0 | | 21 | BAS-81 | Dec Time-6 | 59.0 | |

| | | | | | | | |
|----|--------|----------------|-------------------|----|--------|----------------|-------------------|
| 22 | BAS-82 | Acc Time-7 | 42.0 | 23 | BAS-83 | Dec Time-7 | 60.0 |
| 24 | ADV-10 | Power-on Run | 1: Yes | 25 | ADV-25 | Freq Limit Lo | 20.00 |
| 26 | ADV-50 | E-Save Mode | 2: Auto | 27 | ADV-64 | FAN Control | 2: Temp Control |
| 28 | ADV-65 | U/D Save Mode | 1: Yes | 29 | CON-4 | Carrier Freq | 3.0 |
| 30 | CON-70 | SS Mode | 0: Flying Start-1 | 31 | CON-77 | KEB Select | 1: Yes |
| 32 | OUT-32 | Relay 2 | 14: Run | 33 | PID-1 | PID Sel | 1: Yes |
| 34 | PID-3 | PID Output | - | 35 | PID-4 | PID Ref Value | - |
| 36 | PID-5 | PID Fdb Value | - | 37 | PID-10 | PID Ref 1 Src | 4: I2 |
| 38 | PID-11 | PID Ref 1 Set | 5.000 | 39 | PID-25 | PID P-Gain 1 | 50.00 |
| 40 | PID-26 | PID I-Time 1 | 5.0 | 41 | PID-50 | PID Unit Sel | 2: PSI |
| 42 | PID-51 | PID Unit Scale | 3: x0.1 | 43 | AP1-8 | PID Sleep1Freq | 10.00 |
| 44 | AP1-21 | Pre-PID Freq | 30.00 | 45 | AP1-22 | Pre-PID Delay | 120.0 |
| 46 | PRT-8 | RST Restart | 11 | 47 | PRT-9 | Retry Number | 3 |
| 48 | PRT-10 | Retry Delay | 5.0 | 49 | PRT-11 | Lost KPD Mode | 3: Dec |
| 50 | PRT-12 | Lost Cmd Mode | 3: Hold Input | 51 | PRT-40 | ETH Trip Sel | 1: Free Run |
| 52 | PRT-42 | ETH 1 min | 120 | 53 | PRT-52 | Stall Level 1 | 130 |
| 54 | PRT-60 | PipeBroken Sel | 1: Warning | 55 | PRT-61 | PipeBroken Lev | 90.0 |
| 56 | PRT-62 | Pipe Broken DT | 22.0 | 57 | PRT-70 | LDT Sel | 1: Warning |
| 58 | PRT-72 | LDT Source | 0: Output Current | 59 | PRT-75 | LDT Band Width | LDT Source/10% of |

Table of Functions

| | | | | | | | the Max. value |
|----|--------|--------------|-----------|----|--------|----------------|----------------|
| 60 | PRT-76 | LDT Freq | 10.00 | 61 | PRT-77 | LDT Restart DT | 100.0 |
| 62 | M2-4 | M2-Acc Time | 10.0 | 63 | M2-5 | M2-Dec Time | 20.0 |
| 64 | M2-25 | M2-V/F Patt | 1: Square | 65 | M2-28 | M2-Stall Lev | 125 |
| 66 | M2-29 | M2-ETH 1 min | 120 | | | | |

8.16.6 Vacuum Pump (MC6) Group

| Macro Code | Code | LCD Display | Initial Value | | Macro Code | Code | LCD Display | Initial Value | |
|------------|--------|--------------|----------------|-------|------------|--------|---------------|---------------|-------|
| 0 | - | Jump Code | 1: CODE | | 1 | DRV-3 | Acc Time | 0.75~90 kW | 30.0 |
| | | | | | | | | 110~250 kW | 90.0 |
| | | | | | | | | 315~500 kW | 150.0 |
| 2 | DRV-4 | Dec Time | 0.75~90 kW | 60.0 | 3 | DRV-7 | Freq Ref Src | 1: Keypad-2 | |
| | | | 110~250 kW | 180.0 | | | | | |
| | | | 315~500 kW | 300.0 | | | | | |
| 4 | DRV-9 | Control Mode | 1: Slip Compen | | 5 | DRV-11 | JOG Frequency | 20.00 | |
| 6 | DRV-12 | JOG Acc Time | 30.0 | | 7 | DRV-13 | JOG Dec Time | 60.0 | |
| 8 | DRV-15 | Torque Boost | 1: Auto1 | | 9 | BAS-7 | V/F Pattern | 1: Square | |
| 10 | BAS-70 | Acc Time-1 | 30.0 | | 11 | BAS-71 | Dec Time-1 | 50.0 | |
| 12 | BAS-72 | Acc Time-2 | 32.0 | | 13 | BAS-73 | Dec Time-2 | 52.0 | |
| 14 | BAS-74 | Acc Time-3 | 34.0 | | 15 | BAS-75 | Dec Time-3 | 54.0 | |
| 16 | BAS-76 | Acc Time-4 | 36.0 | | 17 | BAS-77 | Dec Time-4 | 56.0 | |
| 18 | BAS-78 | Acc Time-5 | 38.0 | | 19 | BAS-79 | Dec Time-5 | 58.0 | |
| 20 | BAS-80 | Acc Time-6 | 40.0 | | 21 | BAS-81 | Dec Time-6 | 59.0 | |
| 22 | BAS-82 | Acc Time-7 | 42.0 | | 23 | BAS-83 | Dec Time-7 | 60.0 | |

Table of Functions

| Macro Code | Code | LCD Display | Initial Value | | Macro Code | Code | LCD Display | Initial Value | |
|------------|--------|--------------|-----------------|-------|------------|--------|---------------|-------------------|-------|
| 0 | - | Jump Code | 1: CODE | | 1 | DRV-3 | Acc Time | 0.75~90 kW | 30.0 |
| | | | | | | | | 110~250 kW | 90.0 |
| | | | | | | | | 315~500 kW | 150.0 |
| 2 | DRV-4 | Dec Time | 0.75~90 kW | 60.0 | 3 | DRV-7 | Freq Ref Src | 1: Keypad-2 | |
| | | | 110~250 kW | 180.0 | | | | | |
| | | | 315~500 kW | 300.0 | | | | | |
| 4 | DRV-9 | Control Mode | 1: Slip Compen | | 5 | DRV-11 | JOG Frequency | 20.00 | |
| 6 | DRV-12 | JOG Acc Time | 30.0 | | 7 | DRV-13 | JOG Dec Time | 60.0 | |
| 8 | DRV-15 | Torque Boost | 1: Auto1 | | 9 | BAS-7 | V/F Pattern | 1: Square | |
| 10 | BAS-70 | Acc Time-1 | 30.0 | | 11 | BAS-71 | Dec Time-1 | 50.0 | |
| 12 | BAS-72 | Acc Time-2 | 32.0 | | 13 | BAS-73 | Dec Time-2 | 52.0 | |
| 14 | BAS-74 | Acc Time-3 | 34.0 | | 15 | BAS-75 | Dec Time-3 | 54.0 | |
| 16 | BAS-76 | Acc Time-4 | 36.0 | | 17 | BAS-77 | Dec Time-4 | 56.0 | |
| 24 | ADV-10 | Power-on Run | 1: Yes | | 25 | ADV-25 | Freq Limit Lo | 40.00 | |
| 26 | ADV-64 | FAN Control | 2: Temp Control | | 27 | ADV-65 | U/D Save Mode | 1: Yes | |
| 28 | CON-4 | Carrier Freq | 3.0 | | 29 | CON-70 | SS Mode | 0: Flying Start-1 | |
| 30 | CON-77 | KEB Select | 1: Yes | | 31 | OUT-32 | Relay 2 | 14: Run | |

| Macro Code | Code | LCD Display | Initial Value | | Macro Code | Code | LCD Display | Initial Value | |
|------------|--------|---------------|----------------|-------|------------|--------|---------------|---------------|-------|
| 0 | - | Jump Code | 1: CODE | | 1 | DRV-3 | Acc Time | 0.75~90 kW | 30.0 |
| | | | | | | | | 110~250 kW | 90.0 |
| | | | | | | | | 315~500 kW | 150.0 |
| 2 | DRV-4 | Dec Time | 0.75~90 kW | 60.0 | 3 | DRV-7 | Freq Ref Src | 1: Keypad-2 | |
| | | | 110~250 kW | 180.0 | | | | | |
| | | | 315~500 kW | 300.0 | | | | | |
| 4 | DRV-9 | Control Mode | 1: Slip Compen | | 5 | DRV-11 | JOG Frequency | 20.00 | |
| 6 | DRV-12 | JOG Acc Time | 30.0 | | 7 | DRV-13 | JOG Dec Time | 60.0 | |
| 8 | DRV-15 | Torque Boost | 1: Auto1 | | 9 | BAS-7 | V/F Pattern | 1: Square | |
| 10 | BAS-70 | Acc Time-1 | 30.0 | | 11 | BAS-71 | Dec Time-1 | 50.0 | |
| 12 | BAS-72 | Acc Time-2 | 32.0 | | 13 | BAS-73 | Dec Time-2 | 52.0 | |
| 14 | BAS-74 | Acc Time-3 | 34.0 | | 15 | BAS-75 | Dec Time-3 | 54.0 | |
| 16 | BAS-76 | Acc Time-4 | 36.0 | | 17 | BAS-77 | Dec Time-4 | 56.0 | |
| 32 | PID-1 | PID Sel | 1: Yes | | 33 | PID-3 | PID Output | - | |
| 34 | PID-4 | PID Ref Value | - | | 35 | PID-5 | PID Fdb Value | - | |
| 36 | PID-10 | PID Ref 1 Src | 4: I2 | | 37 | PID-11 | PID Ref 1 Set | 5.000 | |
| 38 | PID-25 | PID P-Gain 1 | 50.00 | | 39 | PID-26 | PID I-Time 1 | 2.5 | |

Table of Functions

| Macro Code | Code | LCD Display | Initial Value | | Macro Code | Code | LCD Display | Initial Value | |
|------------|--------|---------------|-----------------|-------|------------|--------|----------------|---------------|-------|
| | | | | | | | | | |
| 0 | - | Jump Code | 1: CODE | | 1 | DRV-3 | Acc Time | 0.75~90 kW | 30.0 |
| | | | | | | | | 110~250 kW | 90.0 |
| | | | | | | | | 315~500 kW | 150.0 |
| 2 | DRV-4 | Dec Time | 0.75~90 kW | 60.0 | 3 | DRV-7 | Freq Ref Src | 1: Keypad-2 | |
| | | | 110~250 kW | 180.0 | | | | | |
| | | | 315~500 kW | 300.0 | | | | | |
| 4 | DRV-9 | Control Mode | 1: Slip Compens | | 5 | DRV-11 | JOG Frequency | 20.00 | |
| 6 | DRV-12 | JOG Acc Time | 30.0 | | 7 | DRV-13 | JOG Dec Time | 60.0 | |
| 8 | DRV-15 | Torque Boost | 1: Auto1 | | 9 | BAS-7 | V/F Pattern | 1: Square | |
| 10 | BAS-70 | Acc Time-1 | 30.0 | | 11 | BAS-71 | Dec Time-1 | 50.0 | |
| 12 | BAS-72 | Acc Time-2 | 32.0 | | 13 | BAS-73 | Dec Time-2 | 52.0 | |
| 14 | BAS-74 | Acc Time-3 | 34.0 | | 15 | BAS-75 | Dec Time-3 | 54.0 | |
| 16 | BAS-76 | Acc Time-4 | 36.0 | | 17 | BAS-77 | Dec Time-4 | 56.0 | |
| 40 | PID-50 | PID Unit Sel | 5: inWC | | 41 | PID-51 | PID Unit Scale | 3: x0.1 | |
| 42 | AP1-21 | Pre-PID Freq | 30.00 | | 43 | PRT-8 | RST Restart | 11 | |
| 44 | PRT-9 | Retry Number | 3 | | 45 | PRT-10 | Retry Delay | 4.0 | |
| 46 | PRT-11 | Lost KPD Mode | 3: Dec | | 47 | PRT-12 | Lost Cmd Mode | 3: Hold Input | |

| Macro Code | Code | LCD Display | Initial Value | | Macro Code | Code | LCD Display | Initial Value | |
|------------|--------|----------------|----------------|-------|------------|--------|----------------|---------------|-------|
| 0 | - | Jump Code | 1: CODE | | 1 | DRV-3 | Acc Time | 0.75~90 kW | 30.0 |
| | | | | | | | | 110~250 kW | 90.0 |
| | | | | | | | | 315~500 kW | 150.0 |
| 2 | DRV-4 | Dec Time | 0.75~90 kW | 60.0 | 3 | DRV-7 | Freq Ref Src | 1: Keypad-2 | |
| | | | 110~250 kW | 180.0 | | | | | |
| | | | 315~500 kW | 300.0 | | | | | |
| 4 | DRV-9 | Control Mode | 1: Slip Compen | | 5 | DRV-11 | JOG Frequency | 20.00 | |
| 6 | DRV-12 | JOG Acc Time | 30.0 | | 7 | DRV-13 | JOG Dec Time | 60.0 | |
| 8 | DRV-15 | Torque Boost | 1: Auto1 | | 9 | BAS-7 | V/F Pattern | 1: Square | |
| 10 | BAS-70 | Acc Time-1 | 30.0 | | 11 | BAS-71 | Dec Time-1 | 50.0 | |
| 12 | BAS-72 | Acc Time-2 | 32.0 | | 13 | BAS-73 | Dec Time-2 | 52.0 | |
| 14 | BAS-74 | Acc Time-3 | 34.0 | | 15 | BAS-75 | Dec Time-3 | 54.0 | |
| 16 | BAS-76 | Acc Time-4 | 36.0 | | 17 | BAS-77 | Dec Time-4 | 56.0 | |
| 48 | PRT-40 | ETH Trip Sel | 1: Free Run | | 49 | PRT-42 | ETH 1 min | 120 | |
| 50 | PRT-52 | Stall Level 1 | 130 | | 51 | PRT-60 | PipeBroken Sel | 1: Warning | |
| 52 | PRT-61 | PipeBroken Lev | 90.0 | | 53 | PRT-62 | Pipe Broken DT | 22.0 | |
| 54 | PRT- | DB | 10 | | 55 | PRT- | LDT Sel | 1: Warning | |

Table of Functions

| Macro Code | Code | LCD Display | Initial Value | | Macro Code | Code | LCD Display | Initial Value | |
|------------|--------|--------------|-------------------|-------|------------|--------|----------------|-----------------------------------|-------|
| 0 | - | Jump Code | 1: CODE | | 1 | DRV-3 | Acc Time | 0.75~90 kW | 30.0 |
| | | | | | | | | 110~250 kW | 90.0 |
| | | | | | | | | 315~500 kW | 150.0 |
| 2 | DRV-4 | Dec Time | 0.75~90 kW | 60.0 | 3 | DRV-7 | Freq Ref Src | 1: Keypad-2 | |
| | | | 110~250 kW | 180.0 | | | | | |
| | | | 315~500 kW | 300.0 | | | | | |
| 4 | DRV-9 | Control Mode | 1: Slip Compens | | 5 | DRV-11 | JOG Frequency | 20.00 | |
| 6 | DRV-12 | JOG Acc Time | 30.0 | | 7 | DRV-13 | JOG Dec Time | 60.0 | |
| 8 | DRV-15 | Torque Boost | 1: Auto1 | | 9 | BAS-7 | V/F Pattern | 1: Square | |
| 10 | BAS-70 | Acc Time-1 | 30.0 | | 11 | BAS-71 | Dec Time-1 | 50.0 | |
| 12 | BAS-72 | Acc Time-2 | 32.0 | | 13 | BAS-73 | Dec Time-2 | 52.0 | |
| 14 | BAS-74 | Acc Time-3 | 34.0 | | 15 | BAS-75 | Dec Time-3 | 54.0 | |
| 16 | BAS-76 | Acc Time-4 | 36.0 | | 17 | BAS-77 | Dec Time-4 | 56.0 | |
| | 66 | Warn %E D | | | | 70 | | | |
| 56 | PRT-72 | LDT Source | 0: Output Current | | 57 | PRT-75 | LDT Band Width | LDT Source /10% of the Max. value | |
| 58 | PRT-76 | LDT Freq | 15.00 | | 59 | PRT-77 | LDT Restart DT | 100.0 | |

| Macro Code | Code | LCD Display | Initial Value | | Macro Code | Code | LCD Display | Initial Value | |
|------------|--------|--------------|----------------|-------|------------|--------|---------------|---------------|-------|
| 0 | - | Jump Code | 1: CODE | | 1 | DRV-3 | Acc Time | 0.75~90 kW | 30.0 |
| | | | | | | | | 110~250 kW | 90.0 |
| | | | | | | | | 315~500 kW | 150.0 |
| 2 | DRV-4 | Dec Time | 0.75~90 kW | 60.0 | 3 | DRV-7 | Freq Ref Src | 1: Keypad-2 | |
| | | | 110~250 kW | 180.0 | | | | | |
| | | | 315~500 kW | 300.0 | | | | | |
| 4 | DRV-9 | Control Mode | 1: Slip Compen | | 5 | DRV-11 | JOG Frequency | 20.00 | |
| 6 | DRV-12 | JOG Acc Time | 30.0 | | 7 | DRV-13 | JOG Dec Time | 60.0 | |
| 8 | DRV-15 | Torque Boost | 1: Auto1 | | 9 | BAS-7 | V/F Pattern | 1: Square | |
| 10 | BAS-70 | Acc Time-1 | 30.0 | | 11 | BAS-71 | Dec Time-1 | 50.0 | |
| 12 | BAS-72 | Acc Time-2 | 32.0 | | 13 | BAS-73 | Dec Time-2 | 52.0 | |
| 14 | BAS-74 | Acc Time-3 | 34.0 | | 15 | BAS-75 | Dec Time-3 | 54.0 | |
| 16 | BAS-76 | Acc Time-4 | 36.0 | | 17 | BAS-77 | Dec Time-4 | 56.0 | |
| 60 | M2-4 | M2-Acc Time | 10.0 | | 61 | M2-5 | M2-Dec Time | 20.0 | |
| 62 | M2-8 | M2-Ctrl Mode | 1: Slip Compen | | 63 | M2-25 | M2-V/F Patt | 1: Square | |
| 64 | M2-28 | M2-Stall Lev | 125 | | 65 | M2-29 | M2-ETH 1 min | 120 | |

8.16.7 Constant Torque (MC7) Group

| Macro Code | Code | LCD Display | Initial Value | | Macro Code | Code | LCD Display | Initial Value | |
|------------|--------|--------------|----------------|-------|------------|--------|--------------|---------------|-------|
| 0 | - | Jump Code | 1:CODE | | 1 | DRV-3 | Acc Time | 0.75~90 kW | 30.0 |
| | | | | | | | | 110~250 kW | 90.0 |
| | | | | | | | | 315~500 kW | 150.0 |
| 2 | DRV-4 | Dec Time | 0.75~90 kW | 32.0 | 3 | DRV-7 | Freq Ref Src | 1: Keypad-2 | |
| | | | 110~250 kW | 60.0 | | | | | |
| | | | 315~500 kW | 100.0 | | | | | |
| 4 | DRV-9 | Control Mode | 1: Slip Compen | | 5 | DRV-12 | JOG Acc Time | 10.0 | |
| 6 | DRV-13 | JOG Dec Time | 20.0 | | 7 | DRV-15 | Torque Boost | 1: Auto1 | |
| 8 | BAS-70 | Acc Time-1 | 10.0 | | 9 | BAS-71 | Dec Time-1 | 20.0 | |
| 10 | BAS-72 | Acc Time-2 | 12.5 | | 11 | BAS-73 | Dec Time-2 | 22.5 | |
| 12 | BAS-74 | Acc Time-3 | 15.0 | | 13 | BAS-75 | Dec Time-3 | 25.0 | |
| 14 | BAS-76 | Acc Time-4 | 17.5 | | 15 | BAS-77 | Dec Time-4 | 27.5 | |
| 16 | BAS-78 | Acc Time-5 | 20.0 | | 17 | BAS-79 | Dec Time-5 | 30.0 | |
| 18 | BAS-80 | Acc Time-6 | 22.5 | | 19 | BAS-81 | Dec Time-6 | 32.5 | |
| 20 | BAS-82 | Acc Time-7 | 25.0 | | 21 | BAS-83 | Dec Time-7 | 35.0 | |
| 22 | ADV- | Acc | 1: S-curve | | 23 | ADV- | Dec | 1: S-curve | |

| Macro Code | Code | LCD Display | Initial Value | | Macro Code | Code | LCD Display | Initial Value | |
|------------|--------|---------------|----------------|-------|------------|--------|---------------|-------------------|-------|
| 0 | - | Jump Code | 1:CODE | | 1 | DRV-3 | Acc Time | 0.75~90 kW | 30.0 |
| | | | | | | | | 110~250 kW | 90.0 |
| | | | | | | | | 315~500 kW | 150.0 |
| 2 | DRV-4 | Dec Time | 0.75~90 kW | 32.0 | 3 | DRV-7 | Freq Ref Src | 1: Keypad-2 | |
| | | | 110~250 kW | 60.0 | | | | | |
| | | | 315~500 kW | 100.0 | | | | | |
| 4 | DRV-9 | Control Mode | 1: Slip Compen | | 5 | DRV-12 | JOG Acc Time | 10.0 | |
| 6 | DRV-13 | JOG Dec Time | 20.0 | | 7 | DRV-15 | Torque Boost | 1: Auto1 | |
| 8 | BAS-70 | Acc Time-1 | 10.0 | | 9 | BAS-71 | Dec Time-1 | 20.0 | |
| 10 | BAS-72 | Acc Time-2 | 12.5 | | 11 | BAS-73 | Dec Time-2 | 22.5 | |
| | 1 | Pattern | | | | 2 | Pattern | | |
| 24 | ADV-25 | Freq Limit Lo | 20.00 | | 25 | ADV-74 | RegenAv d Sel | 1: Yes | |
| 26 | CON-4 | Carrier Freq | 3.0 | | 27 | CON-70 | SS Mode | 0: Flying Start-1 | |
| 28 | CON-77 | KEB Select | 1: Yes | | 29 | OUT-32 | Relay 2 | 14: Run | |
| 30 | AP1-21 | Pre-PID Freq | 30.00 | | 31 | AP1-22 | Pre-PID Delay | 120.0 | |
| 32 | PRT-12 | Lost Cmd Mode | 2: Dec | | 33 | PRT-40 | ETH-Trip Sel | 2:Dec | |

Table of Functions

| Macro Code | Code | LCD Display | Initial Value | | Macro Code | Code | LCD Display | Initial Value | |
|------------|--------|--------------|------------------|-------|------------|--------|----------------|----------------------------------|-------|
| 0 | - | Jump Code | 1:CODE | | 1 | DRV-3 | Acc Time | 0.75~90 kW | 30.0 |
| | | | | | | | | 110~250 kW | 90.0 |
| | | | | | | | | 315~500 kW | 150.0 |
| 2 | DRV-4 | Dec Time | 0.75~90 kW | 32.0 | 3 | DRV-7 | Freq Ref Src | 1: Keypad-2 | |
| | | | 110~250 kW | 60.0 | | | | | |
| | | | 315~500 kW | 100.0 | | | | | |
| 4 | DRV-9 | Control Mode | 1: Slip Compen | | 5 | DRV-12 | JOG Acc Time | 10.0 | |
| 6 | DRV-13 | JOG Dec Time | 20.0 | | 7 | DRV-15 | Torque Boost | 1: Auto1 | |
| 8 | BAS-70 | Acc Time-1 | 10.0 | | 9 | BAS-71 | Dec Time-1 | 20.0 | |
| 10 | BAS-72 | Acc Time-2 | 12.5 | | 11 | BAS-73 | Dec Time-2 | 22.5 | |
| 34 | PRT-66 | DB Warn %E D | 10 | | 35 | PRT-70 | LDT Sel | 1: Warning | |
| 36 | PRT-72 | LDT Source | 0:Output Current | | 37 | PRT-75 | LDT Band Width | LDT Source/10% of the Max. value | |
| 38 | PRT-76 | LDT Freq | 5.00 | | 39 | PRT-77 | LDT Restart DT | 250.0 | |
| 40 | M2-4 | M2-Acc Time | 10.0 | | 41 | M2-5 | M2-Dec Time | 20.0 | |
| 42 | M2-8 | M2-Ctrl Mode | 1: Slip Compen | | | | | | |

9 Troubleshooting

This chapter explains how to troubleshoot a problem when inverter protective functions, fault trips, warning signals, or faults occur. If the inverter does not work normally after following the suggested troubleshooting steps, please contact the LS ELECTRIC customer service center.

9.1 Trip and Warning

When the inverter detects a fault, it stops the operation (trips) or sends out a warning signal. When a trip or warning occurs, the keypad displays the information briefly. Detailed information is shown on the LCD display. Users can read the warning message at PRT-90. When more than 2 trips occur at roughly the same time, the keypad displays the higher priority fault information. In the keypad, fault trips with higher priority are displayed first. Use the [Up], [Down], [Left] or [Right] cursor key on the keypad to view the fault trip information. The fault conditions can be categorized as follows

- Level: When the fault is corrected, the trip or warning signal disappears and the fault is not saved in the fault history.
- Latch: When the fault is corrected and a reset input signal is provided, the trip or warning signal disappears.
- Fatal: When the fault is corrected, the fault trip or warning signal disappears only after the user turns off the inverter, waits until the charge indicator light goes off, and turns the inverter on again. If the inverter is still in a fault condition after powering it on again, please contact the supplier or the LS ELECTRIC customer service center.

9.1.1 Fault Trips

Protection Functions for Output Current and Input Voltage

| LCD Display | Type | Description |
|-------------|-------|---|
| Over Load | Latch | Displayed when the motor overload trip is activated and the actual load level exceeds the set level. Operates when PRT-20 is set to a value other than '0'. |
| Under Load | Latch | Displayed when the motor underload trip is activated and the actual load level is less than the set level. Operates when PRT-27 is set to a value other than '0'. |

| LCD Display | Type | Description |
|----------------|-------|---|
| Over Current1 | Latch | Displayed when inverter output current exceeds 180% of the rated current. |
| Over Voltage | Latch | Displayed when internal DC circuit voltage exceeds the specified value. |
| Low Voltage | Level | Displayed when internal DC circuit voltage is less than the specified value. |
| Low Voltage2 | Latch | Displayed when internal DC circuit voltage is less than the specified value during inverter operation. |
| Ground Trip | Latch | Displayed when a ground fault trip occurs on the output side of the inverter and causes the current to exceed the specified value. The specified value varies depending on inverter capacity. |
| E-Thermal | Latch | Displayed based on inverse time-limit thermal characteristics to prevent motor overheating. Operates when PRT-40 is set to a value other than '0'. |
| Out Phase Open | Latch | Displayed when a 3-phase inverter output has one or more phases in an open circuit condition. Operates when bit 1 of PRT-05 is set to '1'. |
| In Phase Open | Latch | Displayed when a 3-phase inverter input has one or more phases in an open circuit condition. Operates only when bit 2 of PRT-05 is set to '1'. |
| Inverter OLT | Latch | Displayed when the inverter has been protected from overload and resultant overheating, based on inverse time-limit thermal characteristics. Allowable overload rates for the inverter are 120% for 1 min and 140% for 5 sec. |
| No Motor Trip | Latch | Displayed when the motor is not connected during inverter operation. Operates when PRT-31 is set to '1'. |

Protection Functions Using Abnormal Internal Circuit Conditions and External Signals

| LCD Display | Type | Description |
|---------------|-------|--|
| Over Heat | Latch | Displayed when the temperature of the inverter heat sink exceeds the specified value. |
| Over Current2 | Latch | Displayed when the DC circuit in the inverter detects a specified level of excessive, short circuit current. |
| External Trip | Latch | Displayed when an external fault signal is provided by the |

| LCD Display | Type | Description |
|--------------|-------|--|
| | | multi-function terminal. Set one of the multi-function input terminals at IN-65-71 to '4 (External Trip)' to enable external trip. |
| BX | Level | Displayed when the inverter output is blocked by a signal provided from the multi-function terminal. Set one of the multi-function input terminals at IN-65-71 to '5 (BX)' to enable input block function. |
| HW-Diag | Fatal | Displayed when an error is detected in the memory (EEPROM), analog-digital converter output (ADC Off Set) or CPU watchdog (Watch Dog-1, Watch Dog-2). EEP Err: An error in reading/writing parameters due to keypad or memory (EEPROM) fault. ADC Off Set: An error in the current sensing circuit (U/V/W terminal, current sensor, etc.). |
| NTC Open | Latch | Displayed when an error is detected in the temperature sensor of the Insulated Gate Bipolar Transistor (IGBT). |
| Fan Trip | Latch | Displayed when an error is detected in the cooling fan. Set PRT-79 to '0' to activate fan trip (for models below 22 kW capacity). |
| InFan Trip | Latch | It occurs when an abnormality is detected in the cooling fan inside the inverter with inverter capacity of 110 kW to 500 kW. Selecting PRT - 79 code to 0 will work. |
| Thermal Trip | Latch | Triggered when the input temperature is higher than the temperature set by the user. |
| Lost KeyPad | Latch | Triggered when a communication error occurs between the keypad and the inverter, when the keypad is the command source, and PRT-11 (Lost KPD Mode) is set to any other value than '0'. |
| Fuse Open | Latch | If an input stage fuse breaks with an inverter of 315 kW or more, a fault will occur. |

General Fault Trips

| LCD Display | Type | Description |
|---------------|-------|---|
| Damper Err | Latch | Triggered when the damper open signal or run command signal is longer than the value set at AP2-45 (Damper Check T) during a fan operation. |
| MMC Interlock | Latch | Triggered when AP1-55 is set to '2' and all auxiliary motors are interlocked during an MMC operation. |
| CleanRPTErr | Latch | Triggered when the pump clean operation is operated frequently. The conditions may be modified with the AP2-36–AP2-37 settings. |
| Pipe Broken | Latch | Triggered when a pipe is broken during the pump operation. Set PRT-60. |
| Level Detect | Latch | Triggered when the inverter output current or power is lower or higher than the values set by the user. Set the values at PRT-71–PRT-77. |
| Broken Belt | Latch | Triggered when PRT-91 is set to Free Run |

Option Protection

| LCD Display | Type | Description |
|----------------|-------|---|
| Lost Command | Level | Displayed when a frequency or operation command error is detected during inverter operation by controllers other than the keypad (e.g., using a terminal block and a communication mode). Activate by setting PRT-12 to any value other than '0'. |
| IO Board Trip | Latch | Displayed when the I/O board or external communication card is not connected to the inverter or there is a bad connection. |
| ParaWrite Trip | Latch | Displayed when communication fails during parameter writing. Occurs due to a control cable fault or a bad connection. |
| Option Trip-1 | Latch | Displayed when a communication error is detected between the inverter and the communication board. Occurs when the communication option card is installed. |

9.1.2 Warning Message

| LCD Display | Description |
|---------------|--|
| Over Load | Displayed when a motor is overloaded. Set PRT-17 to '1' to enable. Set OUT-31–35 or OUT-36 to '5 (Over Load)' to receive the overload warning output signals. |
| Under Load | Displayed when the motor is underloaded. Set PRT-25 is to '1'. Set the digital output terminal or relay (OUT-31–35 or OUT-36) to '7 (Under Load)' to receive the underload warning output signals. |
| INV Over Load | Displayed when the overload time equivalent to 60% of the inverter overheat protection (inverter IOLT) level, is accumulated. Set the digital output terminals or relay (OUT-31–35 or OUT-36) to '6 (IOL)' to receive the inverter overload warning output signals. |
| Lost Command | Lost command warning alarm occurs even with PRT-12 set to '0'. The warning alarm occurs based on the condition set at PRT-13-15. Set the digital output terminals or relay (OUT-31–35 or OUT-36) to '13 (Lost Command)' to receive the lost command warning output signals. |
| Fan Warning | Displayed when an error is detected from the cooling fan while PRT-79 is set to '1'. Set the digital output terminals or relay (OUT-31–35 or OUT-36) to '8 (Fan Warning)' to receive the fan warning output signals. |
| DB Warn %ED | Displayed when the DB resistor usage rate exceeds the set value. Set the detection level at PRT-66. |
| Fire Mode | When there is a fire, Fire Mode forces the inverter to ignore certain fault trips and continue to operate. Set the digital output terminals or relay (OUT-31–35 or OUT-36) to '27 (Fire Mode)' to receive the fire mode warning output signals. |
| Pipe Broken | Displayed when a pipe is broken during pump operation. Set the digital output terminals or relay (OUT-31–35 or OUT-36) to '28 (Pipe Broken)' to receive the pipe break warning output signals. |
| Lost Keypad | Displayed when a communication error occurs between the keypad and the inverter, when PRT-11 (Lost KPD Mode) is set to any other value than '0', and a run command is given from the keypad. Set the digital output terminals or relay (OUT-31–35 or OUT-36) to '24 (Lost KPD)' to receive the lost keypad warning output signals. |
| Level Detect | Displayed during a level detect state. Set PRT-70 to '1 (warning)' to enable. |
| CAP. Warning | Displayed when capacitor life expectancy level goes below the level set by the user. Set the digital output terminals or relay (OUT-31–35 or OUT-36) to '34 (CAPWarning)' to receive the capacitor life warning output signals. |

| LCD Display | Description |
|----------------|--|
| Fan ExChange | Displayed when the cooling fans need replacing. Set the digital output terminals or relay (OUT-31–35 or OUT-36) to '35 (FanExChange)' to receive the fan replacement warning output signals. |
| Low Battery | Displayed when the RTC battery voltage drops to or below 2 V. To receive a warning output signal, set PRT-90 (Low Battery) to 'Yes'. |
| Broken Belt | Displayed when PRT-91 is set to warning and the inverter becomes on the condition of broken belt. |
| Load Tune | Displayed when the values of 'AP2-03 and AP2-04' are more than the values of 'AP2-09 and AP2-10' and the function of load tuning is not normal. |
| PareWrite Fail | Displayed when the function of smart copier is not normal. |
| Rs Tune Err | Displayed when the function of Rs tuning is not normal . For example, auto tuning is performed without wiring the motor. |
| Lsig Tune Err | Displayed when the function of Lsigma tuning is not normal . For example, auto tuning is performed without wiring the motor. |
| KPD H.O.A Lock | If [DRV-05 KPD H.O.A Lock] sets HAND-OFF-AUTO disabled, it lasts one second when HAND-OFF-AUTO key is pressed using user keypad |
| InFan Warning | It occurs when an abnormality is detected in the cooling fan inside the inverter with inverter capacity of 110 kW to 500 kW. |

9.2 Troubleshooting Fault Trips

When a fault trip or warning occurs due to a protection function, refer to the following table for possible causes and remedies.

| Type | Cause | Remedy |
|------------|--|---|
| Over Load | The load is greater than the motor's rated capacity. | Ensure that the motor and inverter have appropriate capacity ratings. |
| | The set value for the overload trip level (PRT-21) is too low. | Increase the set value for the overload trip level. |
| Under Load | There is a motor-load connection problem. | Replace the motor and inverter with models with lower capacity. |
| | The set value for underload level (PRT-24) is less than the system's minimum load. | Reduce the set value for the underload level. |

| Type | Cause | Remedy |
|---------------|--|---|
| Over Current1 | Acc/Dec time is too short, compared to load inertia (GD^2). | Increase Acc/Dec time. |
| | The inverter load is greater than the rated capacity. | Replace the inverter with a model that has increased capacity. |
| | The inverter supplied an output while the motor was idling. | Operate the inverter after the motor has stopped or use the speed search function (CON-70). |
| | The mechanical brake of the motor is operating too fast. | Check the mechanical brake. |
| Over Voltage | Deceleration time is too short for the load inertia (GD^2). | Increase the acceleration time. |
| | A generative load occurs at the inverter output. | Use the braking unit. |
| | The input voltage is too high. | Determine if the input voltage is above the specified value. |
| Low Voltage | The input voltage is too low. | Determine if the input voltage is below the specified value. |
| | A load greater than the power capacity is connected to the system (a welder, direct motor connection, etc.) | Increase the power capacity. |
| | The magnetic contactor connected to the power source has a faulty connection. | Replace the magnetic contactor. |
| Low Voltage2 | The input voltage has decreased during the operation. | Determine if the input voltage is above the specified value. |
| | An input phase-loss has occurred. | Check the input wiring. |
| | The power supply magnetic contactor is faulty. | Replace the magnetic contractor. |
| Ground Trip | A ground fault has occurred in the inverter output wiring. | Check the output wiring. |
| | The motor insulation is damaged. | Replace the motor. |
| E-Thermal | The motor has overheated. | Reduce the load or operation frequency. |
| | The inverter load is greater than the rated capacity. | Replace the inverter with a model that has increased capacity. |

| Type | Cause | Remedy |
|---------------------------|---|---|
| | The set value for electronic thermal protection is too low. | Set an appropriate electronic thermal level. |
| | The inverter has been operated at low speed for an extended duration. | Replace the motor with a model that supplies extra power to the cooling fan. |
| Out Phase Open | The magnetic contactor on the output side has a connection fault. | Check the magnetic contactor on the output side. |
| | The output wiring is faulty. | Check the output wiring. |
| In Phase Open | The magnetic contactor on the input side has a connection fault. | Check the magnetic contactor on the input side. |
| | The input wiring is faulty. | Check the input wiring. |
| | The DC link capacitor needs to be replaced. | Replace the DC link capacitor. Contact the retailer or the LS ELECTRIC customer service center. |
| Inverter OLT | The load is greater than the rated motor capacity. | Replace the motor and inverter with models that have increased capacity. |
| | The torque boost level is too high. | Reduce the torque boost level. |
| Over Heat | There is a problem with the cooling system. | Determine if a foreign object is obstructing the air inlet, outlet, or vent. |
| | The inverter cooling fan has been operated for an extended period. | Replace the cooling fan. |
| | The ambient temperature is too high. | Keep the ambient temperature below 50 °C. |
| Over Current ² | Output wiring is short-circuited. | Check the output wiring. |
| | There is a fault with the electronic semiconductor (IGBT). | Do not operate the inverter. Contact the retailer or the LS ELECTRIC customer service center. |
| NTC Open | The ambient temperature is too low. | Keep the ambient temperature above -10 °C. |
| | There is a fault with the internal temperature sensor. | Contact the retailer or the LS ELECTRIC customer service center. |
| Fan Lock / In Fan | A foreign object is obstructing the fan's air vent. | Remove the foreign object from the air inlet or outlet. |
| | The cooling fan needs to be replaced. | Replace the cooling fan. |

9.3 Troubleshooting Other Faults

When a fault other than those identified as fault trips or warnings occurs, refer to the following table for possible causes and remedies.

| Type | Cause | Remedy |
|--|---|---|
| Parameters cannot be set. | The inverter is in operation (driving mode). | Stop the inverter to change to program mode and set the parameter. |
| | The parameter access is incorrect. | Check the correct parameter access level and set the parameter. |
| | The password is incorrect. | Check the password, disable the parameter lock and set the parameter. |
| | Low voltage is detected. | Check the power input to resolve the low voltage and set the parameter. |
| The motor does not rotate. | The frequency command source is set incorrectly. | Check the frequency command source setting. |
| | The operation command source is set incorrectly. | Check the operation command source setting. |
| | Power is not supplied to the terminal R/S/T. | Check the terminal connections R/S/T and U/V/W. |
| | The charge lamp is turned off. | Turn on the inverter. |
| | The operation command is off. | Turn on the operation command. (RUN). |
| | The motor is locked. | Unlock the motor or lower the load level. |
| | The load is too high. | Operate the motor independently. |
| | An emergency stop signal is input. | Reset the emergency stop signal. |
| | The wiring for the control circuit terminal is incorrect. | Check the wiring for the control circuit terminal. |
| | The input option for the frequency command is incorrect. | Check the input option for the frequency command. |
| The input voltage or current for the frequency command is incorrect. | Check the input voltage or current for the frequency command. | |

| Type | Cause | Remedy |
|---|---|---|
| | The PNP/NPN mode is selected incorrectly. | Check the PNP/NPN mode setting. |
| | The frequency command value is too low. | Check the frequency command and input a value above the minimum frequency. |
| | The [OFF] key is pressed. | Check that the stop state is normal, if so resume operation normally. |
| | Motor torque is too low. | Increase the volume of the torque boost. If the fault remains, replace the inverter with a model with increased capacity. |
| The motor rotates in the opposite direction to the command. | The wiring for the motor output cable is incorrect. | Determine if the cable on the output side is wired correctly to the phase (U/V/W) of the motor. |
| | The signal connection between the control circuit terminal (forward/reverse rotation) of the inverter and the forward/reverse rotation signal on the control panel side is incorrect. | Check the forward/reverse rotation wiring. |
| The motor only rotates in one direction. | Reverse rotation prevention is selected. | Remove the reverse rotation prevention. |
| | The reverse rotation signal is not provided, even when a 3-wire sequence is selected. | Check the input signal associated with the 3-wire operation and adjust as necessary. |
| The motor is overheating. | The load is too heavy. | Reduce the load. Increase the Acc/Dec time. |
| | | Check the motor parameters and set the correct values. |
| | | Replace the motor and the inverter with models with appropriate capacity for the load. |
| | The ambient temperature of the motor is too high. | Lower the ambient temperature of the motor. |
| | The phase-to-phase voltage of the motor is insufficient. | Use a motor that can withstand phase-to-phase voltages surges greater than the maximum surge voltage. |

| Type | Cause | Remedy |
|--|---|--|
| | | Only use motors suitable for applications with inverters. |
| | | Connect the AC reactor to the inverter output (set the carrier frequency to 3 kHz). |
| | The motor fan has stopped or the fan is obstructed with debris. | Check the motor fan and remove any foreign objects. |
| The motor stops during acceleration. | The load is too high. | Reduce the load. |
| | | Increase the volume of the torque boost. |
| | | Replace the motor and the inverter with models with capacity appropriate for the load. |
| | The current is too big. | If the output current exceeds the rated load, decrease the torque boost. |
| The motor stops when connected to load. | The load is too high. | Reduce the load. |
| | | Replace the motor and the inverter with models with capacity appropriate for the load. |
| The motor does not accelerate. /The acceleration time is too long. | The frequency command value is low. | Set an appropriate value. |
| | The load is too high. | Reduce the load and increase the acceleration time. Check the mechanical brake status. |
| | The acceleration time is too long. | Change the acceleration time. |
| | The combined values of the motor properties and the inverter parameter are incorrect. | Change the motor related parameters. |
| | The stall prevention level during acceleration is low. | Change the stall prevention level. |
| | The stall prevention level during operation is low. | Change the stall prevention level. |
| Motor speed varies during operation. | There is a high variance in load. | Replace the motor and inverter with models with increased capacity. |
| | The input voltage varies. | Reduce input voltage variation. |

Troubleshooting

| Type | Cause | Remedy |
|--|--|--|
| | Motor speed variations occur at a specific frequency. | Adjust the output frequency to avoid a resonance area. |
| The motor rotation is different from the setting. | The V/F pattern is set incorrectly. | Set a V/F pattern that is suitable for the motor specification. |
| The motor deceleration time is too long even with Dynamic Braking (DB) resistor connected. | The deceleration time is set too long. | Change the setting accordingly. |
| | The motor torque is insufficient. | If motor parameters are normal, it is likely to be a motor capacity fault. Replace the motor with a model with increased capacity. |
| | The load is higher than the internal torque limit determined by the rated current of the inverter. | Replace the inverter with a model with increased capacity. |
| While the inverter is in operation, a control unit malfunctions or noise occurs. | Noise occurs due to switching inside the inverter. | Change the carrier frequency to the minimum value. |
| | | Install a micro surge filter in the inverter output. |
| When the inverter is operating, the earth leakage breaker is activated. | An earth leakage breaker will interrupt the supply if current flows to ground during inverter operation. | Connect the inverter to a ground terminal. |
| | | Check that the ground resistance is less than 100Ω for 200 V inverters and less than 10Ω for 400 V inverters. |
| | | Check the capacity of the earth leakage breaker and make the appropriate connection, based on the rated current of the inverter. |
| | | Lower the carrier frequency. |
| | | Make the cable length between the inverter and the motor as short as possible. |
| The motor vibrates severely and does not rotate normally. | Phase-to-phase voltage of 3-phase power source is not balanced. | Check the input voltage and balance the voltage. |
| | | Check and test the motor's insulation. |

| Type | Cause | Remedy |
|--|---|---|
| The motor makes humming, or loud noises. | Resonance occurs between the motor's natural frequency and the carrier frequency. | Slightly increase or decrease the carrier frequency. |
| | Resonance occurs between the motor's natural frequency and the inverter's output frequency. | Slightly increase or decrease the carrier frequency. Use the frequency jump function to avoid the frequency band where resonance occurs. |
| The motor vibrates/hunts. | The frequency input command is an external, analog command. | In situations of noise inflow on the analog input side that results in command interference, change the input filter time constant (IN-07). |
| | The wiring length between the inverter and the motor is too long. | Ensure that the total cable length between the inverter and the motor is less than 200 m (50 m for motors rated 3.7 kW or lower). |
| The motor does not come to a complete stop when the inverter output stops. | It is difficult to decelerate sufficiently, because DC braking is not operating normally. | Adjust the DC braking parameter. |
| | | Increase the set value for the DC braking current. |
| The output frequency does not increase to the frequency reference. | The frequency reference is within the jump frequency range. | Set the frequency reference higher than the jump frequency range. |
| | The frequency reference is exceeding the upper limit of the frequency command. | Set the upper limit of the frequency command higher than the frequency reference. |
| | Because the load is too heavy, the stall prevention function is working. | Replace the inverter with a model with increased capacity. |
| The cooling fan does not rotate. | The control parameter for the cooling fan is set incorrectly. | Check the control parameter setting for the cooling fan. |

10 Maintenance

This chapter explains how to replace the cooling fan, the regular inspections to complete, and how to store and dispose of the product. An inverter is vulnerable to environmental conditions and faults also occur due to component wear and tear. To prevent breakdowns, please follow the maintenance recommendations in this section.

⚠ Caution

- Before you inspect the product, read all safety instructions contained in this manual.
- Before you clean the product, ensure that the power is off.
- Clean the inverter with a dry cloth. Cleaning with wet cloths, water, solvents, or detergents may result in electric shock or damage to the product .

10.1 Regular Inspection Lists

10.1.1 Daily Inspection

| Inspection area | Inspection item | Inspection details | Inspection method | Inspection standard | Inspection equipment |
|-----------------|---------------------|--|---|--|-----------------------------------|
| All | Ambient environment | Is the ambient temperature and humidity within the design range, and is there any dust or foreign objects present? | <u>Refer to 1.3 Installation Considerations</u> on page <u>10</u> | No icing (ambient temperature: -10 - +50) and no condensation (ambient humidity below 95%) | Thermometer, hygrometer, recorder |
| | Inverter | Is there any abnormal vibration or noise? | Visual inspection | No abnormality | |
| | Power voltage | Is the input and output voltages normal? | Measure voltages between R/ S/ T-phases in. the inverter | <u>Refer to 11.1 Input and Output Specifications</u> on page <u>546</u> | Digital multimeter tester |

| Inspection area | Inspection item | Inspection details | Inspection method | Inspection standard | Inspection equipment |
|----------------------|---------------------|---|---|------------------------------------|--------------------------|
| | | | terminal block. | | |
| Input/Output circuit | Smoothing capacitor | Is there any leakage from the inside? | Visual inspection | No abnormality | - |
| | | Is the capacitor swollen? | | | |
| Cooling system | Cooling fan | Is there any abnormal vibration or noise? | Turn off the system and check operation by rotating the fan manually. | Fan rotates smoothly | - |
| Display | Measuring device | Is the display value normal? | Check the display value on the panel. | Check and manage specified values. | Voltmeter, ammeter, etc. |
| Motor | All | Is there any abnormal vibration or noise? | Visual inspection | No abnormality | - |
| | | Is there any abnormal smell? | Check for overheating or damage. | | |

10.1.2 Annual Inspection

| Inspection area | Inspection item | Inspection details | Inspection method | Judgment standard | Inspection equipment |
|----------------------|-----------------|---|---|--------------------|----------------------|
| Input/Output circuit | All | Megger test (between input/output terminals and earth terminal) | Disconnect inverter and short R/S/T/U/V/W terminals, and then measure from each terminal to | Must be above 5 MΩ | DC 500 V Megger |

| Inspection area | Inspection item | Inspection details | Inspection method | Judgment standard | Inspection equipment |
|------------------------------------|---------------------|---|---|--|------------------------------------|
| | | | the ground terminal using a Megger. | | |
| | | Is there anything loose in the device? | Tighten all screws. | No abnormality | |
| | | Is there any evidence of parts overheating? | Visual inspection | | |
| | Cable connections | Are there any corroded cables? | Visual inspection | No abnormality | - |
| | | Is there any damage to cable insulation? | | | |
| | Terminal block | Is there any damage? | Visual inspection | No abnormality | - |
| | Smoothing condenser | Measure electrostatic capacity. | Measure with capacity meter. | Rated capacity over 85% | Capacity meter |
| | Relay | Is there any chattering noise during operation? | Visual inspection | No abnormality | - |
| | | Is there any damage to the contacts? | Visual inspection | | |
| | Braking resistor | Is there any damage from resistance? | Visual inspection | No abnormality | Digital multimeter / analog tester |
| Check for disconnection. | | Disconnect one side and measure with a tester. | Must be within $\pm 10\%$ of the rated value of the resistor. | | |
| Control circuit Protection circuit | Operation check | Check for output voltage imbalance while the inverter is in | Measure voltage between the inverter | Balance the voltage between phases: within | Digital multimeter or DC voltmeter |

| Inspection area | Inspection item | Inspection details | Inspection method | Judgment standard | Inspection equipment |
|-----------------|-----------------|--|--|---|--------------------------|
| | | operation. | output terminal U/ V/ W. | 4 V for 200 V series and within 8 V for 400 V series. | |
| | | Is there an error in the display circuit after the sequence protection test? | Test the inverter output protection in both short and open circuit conditions. | The circuit must work according to the sequence. | |
| Cooling system | Cooling fan | Are any of the fan parts loose? | Check all connected parts and tighten all screws. | No abnormality | - |
| Display | Display device | Is the display value normal? | Check the command value on the display device. | Specified and managed values must match. | Voltmeter, Ammeter, etc. |

10.1.3 Bi-annual Inspection

| Inspection area | Inspection item | Inspection details | Inspection method | Judgment standard | Inspection equipment |
|-----------------|-----------------------|---|--|--------------------|----------------------|
| Motor | Insulation resistance | Megger test (between the input, output and earth terminals) | Disconnect the cables for terminals U/ V/ W and test the wiring. | Must be above 5 MΩ | DC 500 V Megger |

⚠ Caution

Do not run an insulation resistance test (Megger) on the control circuit as it may result in damage to the product.

10.2 Real Time Clock (RTC) Battery Replacement

A CR2032 Lithium-Manganese battery to power the inverter's built-in RTC (real time clock) is installed on the main PCB. When the battery charge is low, a low battery voltage level warning is given on the keypad display.

The RTC feature and any other features related to the RTC feature, such as the time event control, do not work properly when the battery runs out. Refer to the following battery specifications when a battery replacement is required.

RTC Battery Specifications

Model type: CR 2032 (lithium-manganese)

Nominal voltage: 3 V

Nominal capacity: 220 mAh

Operating temperature range: -20–80 degrees C

Life span (approximately): 53,300 hrs (inverter on) / 25,800 hrs (inverter off)

Follow the instructions below to replace the RTC battery.

⚠ Caution

ESD (Electrostatic discharge) from the human body may damage sensitive electronic components on the PCB. Therefore, be extremely careful not to touch the PCB or the components on the PCB with bare hands while you work on the main PCB.

To prevent damage to the PCB from ESD, touch a metal object with your hands to discharge any electricity before working on the PCB, or wear an anti-static wrist strap and ground it on a metal object.

- 1 Turn off the inverter and make sure that DC link voltage has dropped to a safe level.
- 2 Loosen the screw on the power cover then remove the power cover.

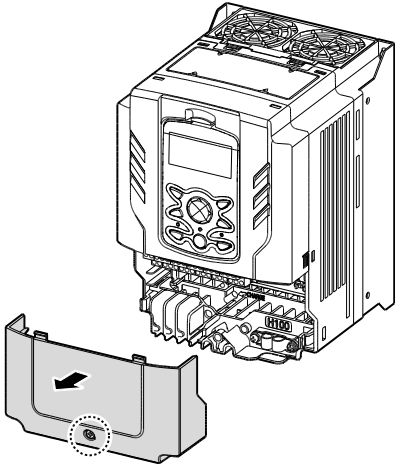

0.75–30 kW Models

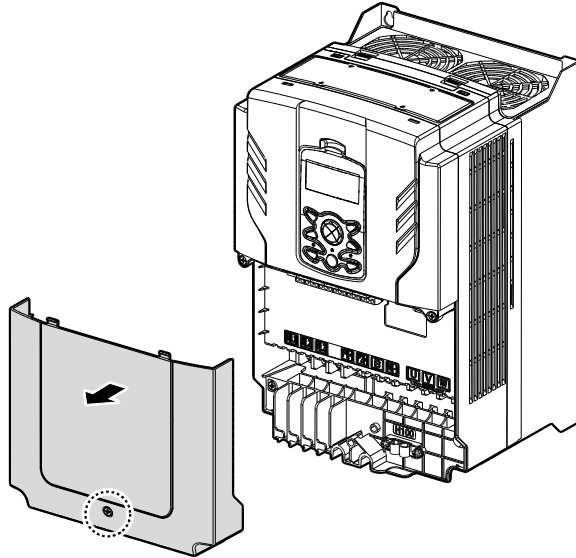

37–90 kW Models

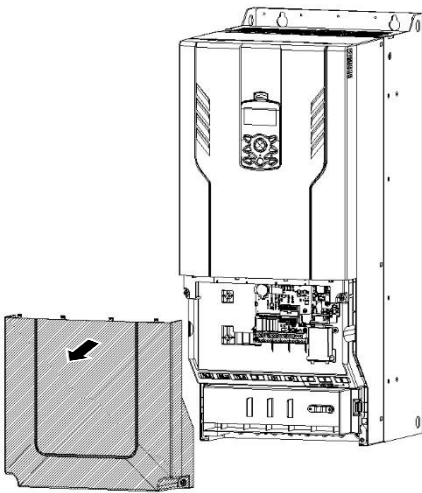

110~185kW Models

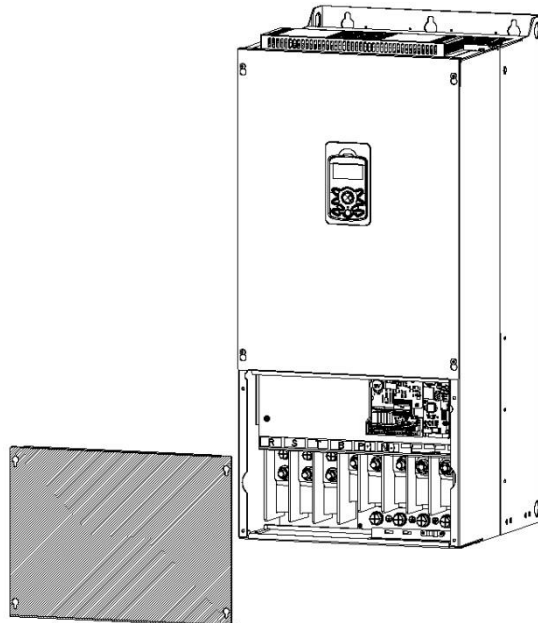

220~500kW Models

- 3 Remove the keypad from the inverter body.

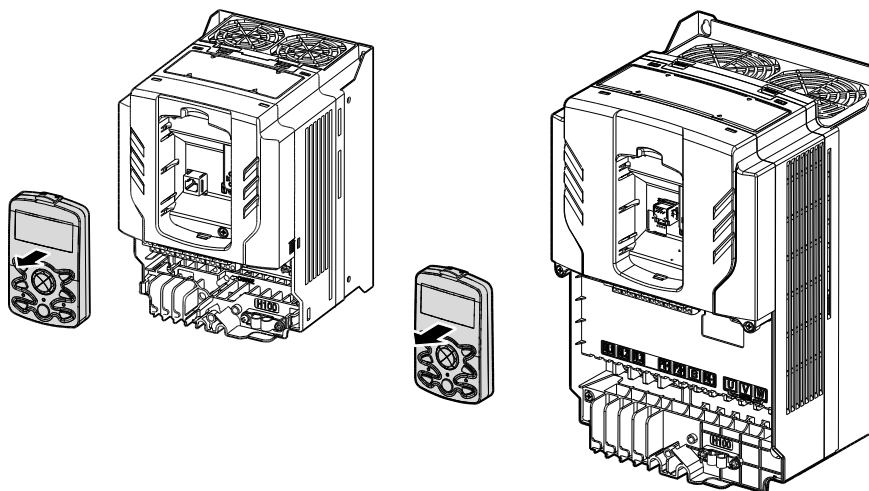

0.75–30 kW Models

37–90 kW Models

- 4 Loosen the screws securing the front cover, and remove the front cover by lifting it. The main PCB is exposed.

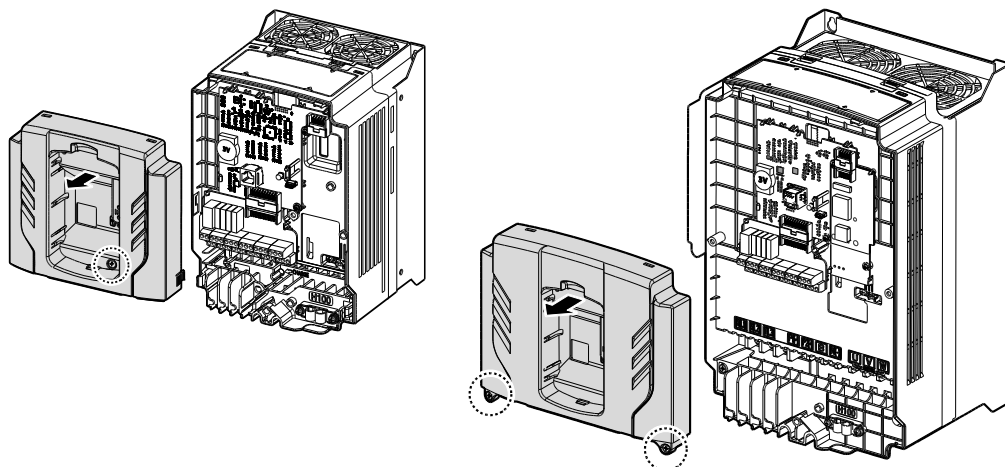

0.75–30 kW Models

37–90 kW Models

- 5 Locate the RTC battery holder on the main PCB, and replace the battery.

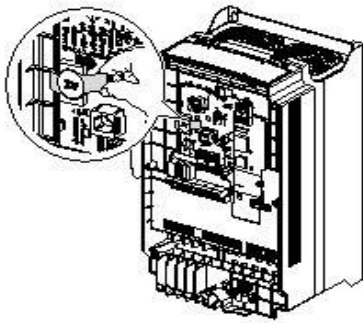

0.75-90kW Models

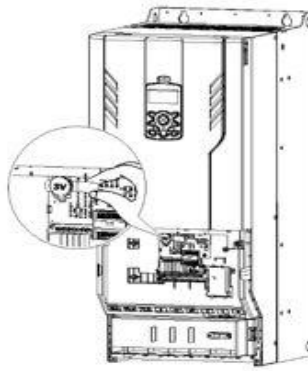

110-185kW Models

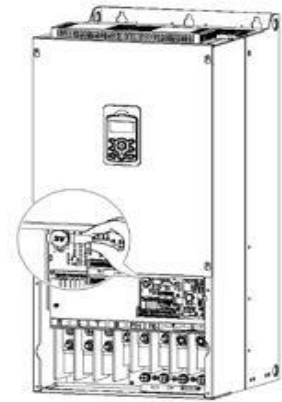

220-500kW Models

6 Reattach the front cover, the power cover, and the keypad back onto the inverter body

⚠ Caution

Ensure that the inverter is turned off and DC link voltage has dropped to a safe level before opening the terminal cover and installing the RTC battery.

10.3 Storage and Disposal

10.3.1 Storage

If you are not using the product for an extended period, store it in the following way:

- Store the product in the same environmental conditions as specified for operation (Refer to Installation Consideration on page 10).
- When storing the product for a period longer than 3 months, store it between -10 °C and 30 °C, to prevent depletion of the electrolytic capacitor.
- Do not expose the inverter to snow, rain, fog, or dust.
- Package the inverter in a way that prevents contact with moisture. Keep the moisture level below 70% in the package by including a desiccant, such as silica gel.
- Do not allow the inverter to be exposed to dusty or humid environments. If the inverter is installed in such environments (for example, a construction site) and the inverter will be unused for an extended period, remove the inverter and store it in a safe place.

10.3.2 Disposal

When disposing of the product, categorize it as general industrial waste. Recyclable materials are included in the product, so recycle them whenever possible. The packing materials and all metal parts can be recycled. Although plastic can also be recycled, it can be incinerated under controlled conditions in some regions.

⚠ Caution

If the inverter has not been operated for a long time, capacitors lose their charging characteristics and are depleted. To prevent depletion, turn on the product once a year and allow the device to operate for 30-60 min. Run the device under no-load conditions.

11 Technical Specification

11.1 Input and Output Specifications

Three Phase 200 V (0.75–3.7 kW)

| Model H100 XXXX-2 | | 0008 | 0015 | 0022 | 0037 | |
|-------------------|----------------------|--------------|---------------------------------|------|------|------|
| Applied Motor | HP | 1.0 | 2.0 | 3.0 | 5.0 | |
| | kW | 0.75 | 1.5 | 2.2 | 3.7 | |
| Rated output | Rated Capacity (kVA) | | 1.9 | 3.0 | 4.5 | 6.1 |
| | Rated Current (A) | Three-Phase | 5 | 8 | 12 | 16 |
| | | Single-Phase | 2.9 | 4.4 | 6.4 | 8.4 |
| | Output Frequency | | 0–400 Hz | | | |
| | Output Voltage (V) | | 3-Phase 200–240 V | | | |
| Rated input | Working Voltage (V) | Three-Phase | 3-Phase 200–240 VAC (-15%–+10%) | | | |
| | | Single-Phase | 1-Phase 240 VAC (-5%–+10%) | | | |
| | Input Frequency | Three-Phase | 50–60 Hz (±5%) | | | |
| | | Single-Phase | 60 Hz(±5%) | | | |
| | Rated Current (A) | | 4.9 | 8.4 | 12.9 | 17.5 |
| Weight (kg) | | 3.3 | 3.3 | 3.3 | 3.3 | |

- The standard motor capacity is based on a standard 4-pole motor.
- The standard used for 200 V inverters is based on a 220 V supply voltage, and 400 V inverters are based on a 440 V supply voltage.
- The rated output current is limited based on the carrier frequency set at CON-04.

Three Phase 200 V (5.5–18.5 kW)

| Model H100 XXXX–2 | | 0055 | 0075 | 0110 | 0150 | 0185 | |
|-------------------|----------------------|--------------|---------------------------------|------|------|------|------|
| Applied Motor | HP | 7.5 | 10 | 15 | 20 | 25 | |
| | kW | 5.5 | 7.5 | 11 | 15 | 18.5 | |
| Rated output | Rated Capacity (kVA) | | 8.4 | 11.4 | 16.0 | 21.3 | 26.3 |
| | Rated Current (A) | Three-Phase | 22 | 30 | 42 | 56 | 69 |
| | | Single-Phase | 11 | 16 | 23 | 30 | 37 |
| | Output Frequency | | 0–400 Hz | | | | |
| | Output Voltage (V) | | 3-Phase 200–240 V | | | | |
| Rated input | Working Voltage (V) | Three-Phase | 3-Phase 200–240 VAC (-15%–+10%) | | | | |
| | | Single-Phase | 1-Phase 240 VAC (-5%–+10%) | | | | |
| | Input Frequency | Three-Phase | 50–60 Hz (±5%) | | | | |
| | | Single-Phase | 60 Hz(±5%) | | | | |
| | Rated Current (A) | | 23.7 | 32.7 | 46.4 | 62.3 | 77.2 |
| Weight (kg) | | 3.3 | 3.3 | 3.3 | 4.6 | 7.1 | |

- The standard motor capacity is based on a standard 4-pole motor.
- The standard used for 200 V inverters is based on a 220 V supply voltage, and 400 V inverters are based on a 440 V supply voltage.
- The rated output current is limited based on the carrier frequency set at CON-04.

Three Phase 400 V (0.75–3.7 kW)

| Model H100 XXXX-4 | | 0008 | 0015 | 0022 | 0037 | |
|-------------------|----------------------|--------------|---------------------------------|------|------|-----|
| Applied Motor | HP | 1.0 | 2.0 | 3.0 | 5.0 | |
| | kW | 0.75 | 1.5 | 2.2 | 3.7 | |
| Rated output | Rated Capacity (kVA) | | 1.9 | 3.0 | 4.5 | 6.1 |
| | Rated Current (A) | Three-Phase | 2.5 | 4 | 6 | 8 |
| | | Single-Phase | 1.6 | 2.4 | 3.5 | 4.6 |
| | Output Frequency | | 0–400 Hz | | | |
| | Output Voltage (V) | | 3-Phase 380–480 V | | | |
| Rated input | Working Voltage (V) | Three-Phase | 3-Phase 380–480 VAC (-15%→+10%) | | | |
| | | Single-Phase | 1-Phase 480 VAC (-5%→+10%) | | | |
| | Input Frequency | Three-Phase | 50–60 Hz (±5%) | | | |
| | | Single-Phase | 60 Hz(±5%) | | | |
| | Rated Current (A) | | 2.4 | 4.2 | 6.5 | 8.7 |
| Weight (kg) | | 3.3 | 3.3 | 3.3 | 3.3 | |

- The standard motor capacity is based on a standard 4-pole motor.
- The standard used for 200 V inverters is based on a 220 V supply voltage, and 400 V inverters are based on a 440 V supply voltage.
- The rated output current is limited based on the carrier frequency set at CON-04.

Three Phase 400 V (5.5–22 kW)

| Model H100 XXXX-4 | | 0055 | 0075 | 0110 | 0150 | 0185 | 0220 | |
|-------------------|---------------------|--------------|---------------------------------|------|------|------|------|------|
| Applied Motor | HP | 7.5 | 10 | 15 | 20 | 25 | 30 | |
| | kW | 5.5 | 7.5 | 11 | 15 | 18.5 | 22 | |
| Rated output | Rated Capacity(kVA) | | 9.1 | 12.2 | 18.3 | 23.0 | 29.0 | 34.3 |
| | Rated Current(A) | Three-Phase | 12 | 16 | 24 | 30 | 38 | 45 |
| | | Single-Phase | 6.8 | 9.2 | 14 | 17 | 22 | 26 |
| | Output Frequency | | 0–400 Hz | | | | | |
| | Output Voltage(V) | | 3-Phase 380–480 V | | | | | |
| Rated input | Working Voltage(V) | Three-Phase | 3-Phase 380–480 VAC (-15%–+10%) | | | | | |
| | | Single-Phase | 1-Phase 480 VAC (-5%–+10%) | | | | | |
| | Input Frequency | Three-Phase | 50–60 Hz (±5%) | | | | | |
| | | Single-Phase | 60 Hz(±5%) | | | | | |
| Rated Current(A) | | 12.2 | 17.5 | 26.5 | 33.4 | 42.5 | 50.7 | |
| Weight(kg) | | 3.3 | 3.3 | 3.4 | 4.6 | 4.8 | 7.5 | |

- The standard motor capacity is based on a standard 4-pole motor.
- The standard used for 200 V inverters is based on a 220 V supply voltage, and 400 V inverters are based on a 440 V supply voltage.
- The rated output current is limited based on the carrier frequency set at CON-04.

Three Phase 400 V (30.0–90.0 kW)

| Model H100 XXXX-4 | | 0300 | 0370 | 0450 | 0550 | 0750 | 0900 | |
|--------------------|----------------------|-------------------|---------------------------------|------|------|-------|-------|-------|
| Applied Motor | HP | 40 | 50 | 60 | 75 | 100 | 125 | |
| | kW | 30 | 37 | 45 | 55 | 75 | 90 | |
| Rated output | Rated Capacity (kVA) | | 46.5 | 57.1 | 69.4 | 82.0 | 108.2 | 128.8 |
| | Rated Current (A) | Three-Phase | 61 | 75 | 91 | 107 | 142 | 169 |
| | | Single-Phase | 36 | 39 | 47 | 55 | 73 | 86 |
| | Output Frequency | | 0–400 Hz | | | | | |
| Output Voltage (V) | | 3-Phase 380–480 V | | | | | | |
| Rated input | Working Voltage (V) | Three-Phase | 3-Phase 380–480 VAC (-15%→+10%) | | | | | |
| | | Single-Phase | 1-Phase 480 VAC (-5%→+10%) | | | | | |
| | Input Frequency | Three-Phase | 50–60 Hz (±5%) | | | | | |
| | | Single-Phase | 60 Hz(±5%) | | | | | |
| | Rated Current (A) | | 69.1 | 69.3 | 84.6 | 100.1 | 133.6 | 160.0 |
| Weight (kg) | | 7.5 | 26 | 35 | 35 | 43 | 43 | |

- The standard motor capacity is based on a standard 4-pole motor.
- The standard used for 200 V inverters is based on a 220 V supply voltage, and 400 V inverters are based on a 440 V supply voltage.
- The rated output current is limited based on the carrier frequency set at CON-04.

Three Phase 400 V (110.0–500.0 kW)

| Model | | H100 | 1320 | 1600 | 1850 | 2200 | 2500 | 3150 | 3550 | 4000 | 5000 | |
|---------------|----------------------|-------------|--------------------------------|-------|-------|-------|-------|-------|-------|-------|-------|-------|
| Applied Motor | HP | 150 | 200 | 250 | 300 | 350 | 400 | 500 | 550 | 650 | 800 | |
| | kW | 110 | 132 | 160 | 185 | 220 | 250 | 315 | 355 | 400 | 500 | |
| Rated output | Rated Capacity (kVA) | | 170 | 201 | 248 | 282 | 329 | 367 | 467 | 520 | 587 | 733 |
| | Rated Current (A) | Three Phase | 223 | 264 | 325 | 370 | 432 | 481 | 613 | 683 | 770 | 962 |
| | Output Frequency | | 0–400 Hz | | | | | | | | | |
| | Output Voltage (V) | | 3-Phase 380–500 V | | | | | | | | | |
| Rated input | Working Voltage (V) | Three Phase | 3-Phase 380–500VAC (-15%–+10%) | | | | | | | | | |
| | Input Frequency | Three Phase | 50–60 Hz (±5%) | | | | | | | | | |
| | Rated Current (A) | | 215.1 | 254.6 | 315.3 | 358.9 | 419.1 | 469.3 | 598.1 | 666.4 | 751.3 | 938.6 |
| Weight (kg) | | 55.8 | 55.8 | 74.7 | 74.7 | 120.0 | 120.0 | 185.5 | 185.5 | 185.5 | 265 | |

- The standard motor capacity is based on a standard 4-pole motor.
- The standard used for 200 V inverters is based on a 220 V supply voltage, and 400 V inverters are based on a 440 V supply voltage.
- The rated output current is limited based on the carrier frequency set at CON-04.

11.2 Product Specification Details

| Items | | Description | | |
|--------------|--|--|--|--|
| Control | Control method | V/F control, Slip compensation. | | |
| | Frequency settings power resolution | Digital command: 0.01 Hz Analog command: 0.06 Hz (60 Hz standard) | | |
| | Frequency accuracy | 1% of maximum output frequency. | | |
| | V/F pattern | Linear, square reduction, user V/F. | | |
| | Overload capacity | 0.75~90kW | Rated current: 120% 1 min. | |
| | | 110~500kW | Rated current: 110% 1 min. | |
| Torque boost | Manual torque boost, automatic torque boost. | | | |
| Operation | Operation type | Select key pad, terminal strip, or communication operation. | | |
| | Frequency settings | Analog type: -10~10 V, 0~10 V, 0~20 mA Digital type: key pad, pulse train input | | |
| | Operation function | PID control 3-wire operation Frequency limit Second function Anti-forward and reverse direction rotation Commercial transition Speed search Power braking Leakage reduction | Up-down operation DC braking Frequency jump Slip compensation Automatic restart Automatic tuning Energy buffering Flux braking Energy Saving | |
| | | Input | Multi function terminal | Select PNP (Source) or NPN (Sink) mode. Functions can be set according to IN-65- IN-71 codes and parameter settings. |

| Items | | Description | | |
|---------------------|--------|--|---|---|
| | | (7EA) P1-P7 | Forward direction operation Reset Emergency stop Multi step speed frequency-high/med/low DC braking during stop Frequency increase 3-wire Select acc/dec/stop MMC Interlock | Reverse direction operation External trip Jog operation Multi step acc/dec-high/med/low Second motor selection Frequency reduction Fix analog command frequency Transition from PID to general operation Pre Heat Pump Cleaning RTC(Time Event) |
| | | Pulse train | 0–32 kHz, Low Level: 0–0.8 V, High Level: 3.5–12 V | |
| | Output | Multi function open collector terminal | | Less than DC 26 V, 50 mA |
| | | Fault signal relay terminal | Fault output and inverter operation status output | N.O.: Less than AC 250 V 2A, DC 30 V, 3A N.C.: Less than AC 250 V 1A, DC 30 V 1A |
| | | Multi function relay terminal | | Less than AC 250 V, 5 A Less than DC 30 V, 5 A |
| | | Analog output | 0–12 Vdc(0–20 mA): Select frequency, output current, output voltage, DC terminal voltage, and others. | |
| Pulse train | | Maximum 32 kHz, 0–12 V | | |
| Protection function | Trip | Over current trip External | Over voltage trip Temperature sensor trip Inverter over heat | |

| Items | | Description | |
|--------------------------------------|------------------------|--|---|
| | | signal trip ARM short circuit current trip Over heat trip Input imaging trip Ground trip Motor over heat trip I/O board link trip No motor trip Parameter writing trip Emergency stop trip Command loss trip External memory error CPU watchdog trip Motor under load trip | Option trip Output imaging trip Inverter overload trip Fan trip Low voltage trip during operation Low voltage trip Analog input error Motor overload trip Pipe broken trip Keypad command lost trip Damper trip Level Detect trip MMC Interlock trip PumpCleannig trip |
| | Alarm | Command loss trip alarm, overload alarm, normal load alarm, inverter overload alarm, fan operation alarm, resistance braking rate alarm, Capacitor life alarm, Pump Clean alarm, Fire Mode Alarm, LDT Alarm. | |
| | Instantaneous blackout | Less than 8 ms: Continue Operation (must be within the rated input voltage and rated output range) More than 8 ms: Auto restart operation | |
| Structure/ working environment | Cooling type | Forced fan cooling structure | |
| | Protection structure | IP 20(0.75~185kW), IP 00(220~500kW) UL Open & Enclosed Type 1 (option) (UL Enclosed Type 1 is satisfied by conduit installation option.) | |
| | Ambient temperature | -10 °C~50 °C (2.5% current derating is applied above 40 °C) No ice or frost should be present. Working under normal load at 50 °C (122 °F), it is | |

| Items | Description |
|-------------------------|--|
| | recommended that less than 75% load is applied. |
| Ambient humidity | Relative humidity less than 95% RH (to avoid condensation forming) |
| Storage temperature. | -20 °C-65 °C (-4-149 °F) |
| Surrounding environment | Prevent contact with corrosive gases, inflammable gases, oil stains, dust, and other pollutants. (0.75~90kW Pollution Degree 3 Environment) (110~500kW Pollution Degree 2 Environment) |
| Operation altitude | Maximum 3,280 ft (1,000m) above sea level for standard operation. After that the driver rated voltage and the rated output current derating by 1% for every extra 328 ft (100m) up to 13,123 ft (4,000m). |
| Operation oscillation | Less than 1.0 G (9.8 m/sec ²). |
| Pressure | 70-106 kPa |

11.3 External Dimensions

0.75–30 kW (3-phase)

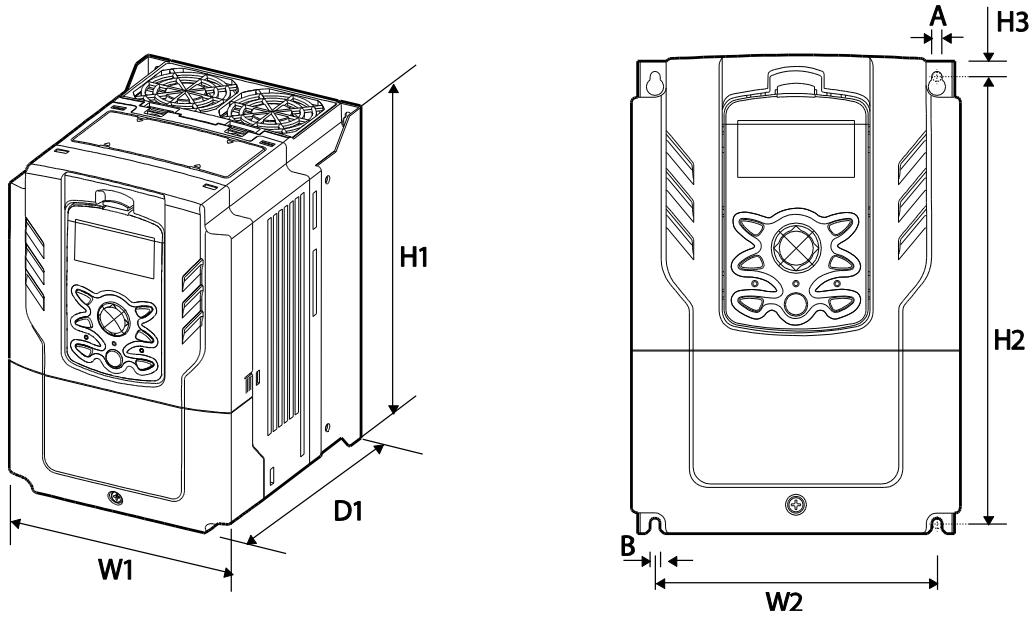

37–90 kW (3-phase)

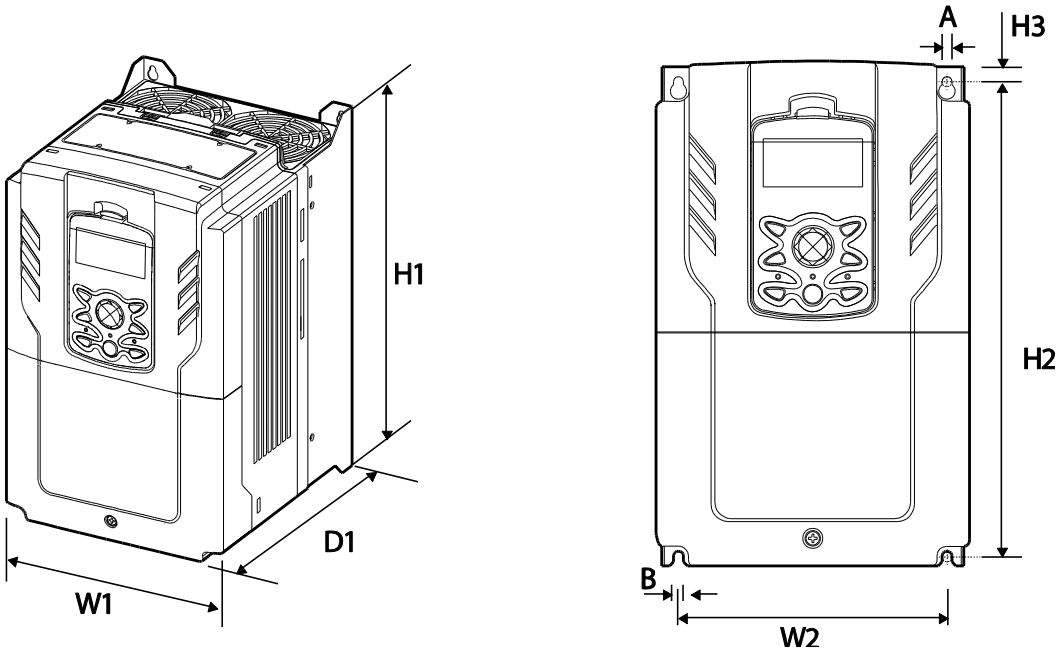

110–185 kW (3-phase)

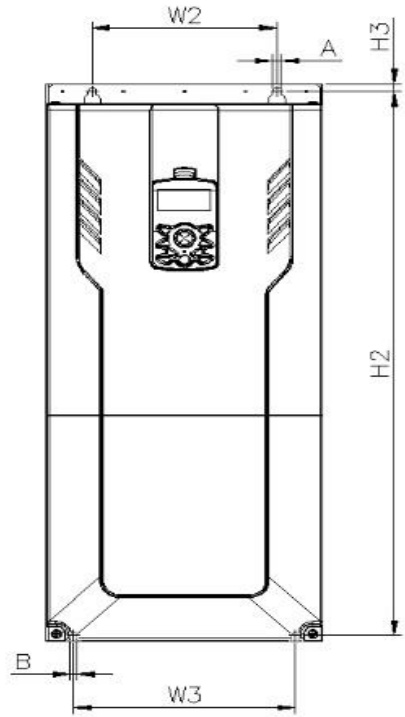
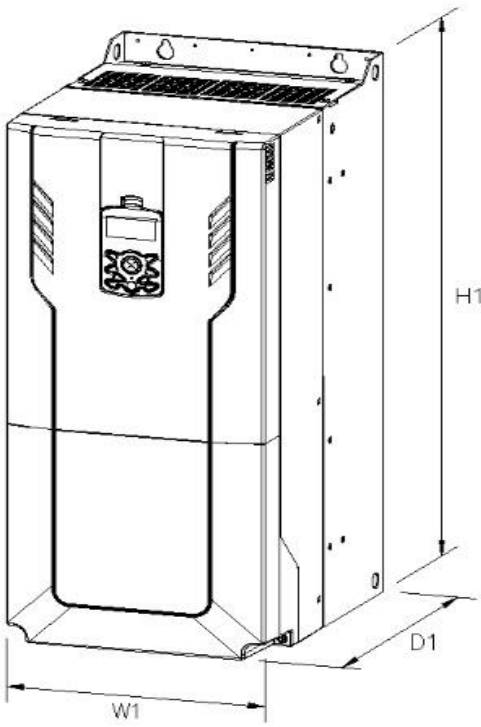

220–500 kW (3-phase)

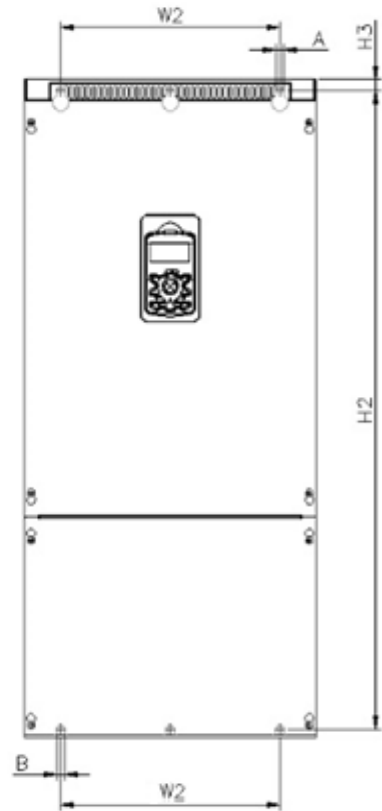
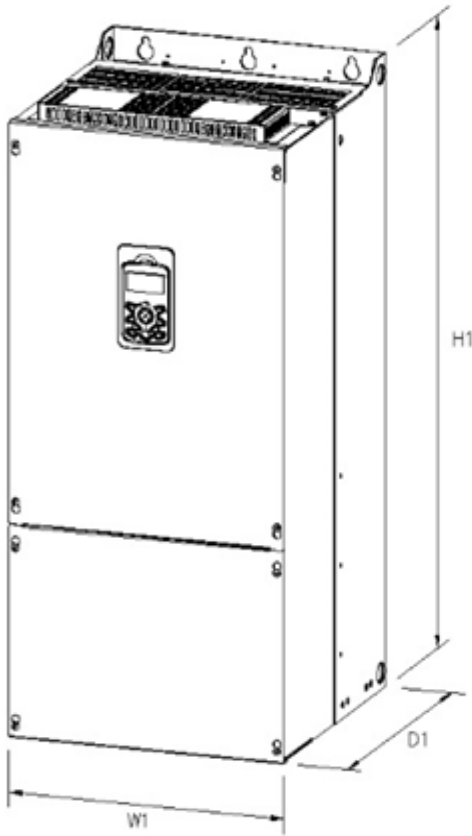

Units: mm

| Items | | W1 | W2 | W3 | H1 | H2 | H3 | D1 | A | B | Φ |
|------------------|------------|-----|-------|----|-----|-------|------|-------|---|---|---|
| 3-phase 200 V | 0008H100-2 | 160 | 137 | - | 232 | 216.5 | 10.5 | 181 | 5 | 5 | - |
| | 0015H100-2 | 160 | 137 | - | 232 | 216.5 | 10.5 | 181 | 5 | 5 | - |
| | 0022H100-2 | 160 | 137 | - | 232 | 216.5 | 10.5 | 181 | 5 | 5 | - |
| | 0037H100-2 | 160 | 137 | - | 232 | 216.5 | 10.5 | 181 | 5 | 5 | - |
| | 0055H100-2 | 160 | 137 | - | 232 | 216.5 | 10.5 | 181 | 5 | 5 | - |
| | 0075H100-2 | 160 | 137 | - | 232 | 216.5 | 10.5 | 181 | 5 | 5 | - |
| | 0110H100-2 | 160 | 137 | - | 232 | 216.5 | 10.5 | 181 | 5 | 5 | - |
| | 0150H100-2 | 180 | 157 | - | 290 | 273.7 | 11.3 | 205.3 | 5 | 5 | - |
| | 0185H100-2 | 220 | 193.8 | - | 350 | 331 | 13 | 223.2 | 6 | 6 | - |
| 3- | 0008H100-4 | 160 | 137 | - | 232 | 216.5 | 10.5 | 181 | 5 | 5 | - |

| | Items | W1 | W2 | W3 | H1 | H2 | H3 | D1 | A | B | Φ |
|----------------|------------|-----|-------|-------|-------|-------|------|-------|----|----|---|
| phase 400 V | 0015H100-4 | 160 | 137 | - | 232 | 216.5 | 10.5 | 181 | 5 | 5 | - |
| | 0022H100-4 | 160 | 137 | - | 232 | 216.5 | 10.5 | 181 | 5 | 5 | - |
| | 0037H100-4 | 160 | 137 | - | 232 | 216.5 | 10.5 | 181 | 5 | 5 | - |
| | 0055H100-4 | 160 | 137 | - | 232 | 216.5 | 10.5 | 181 | 5 | 5 | - |
| | 0075H100-4 | 160 | 137 | - | 232 | 216.5 | 10.5 | 181 | 5 | 5 | - |
| | 0110H100-4 | 160 | 137 | - | 232 | 216.5 | 10.5 | 181 | 5 | 5 | - |
| | 0150H100-4 | 180 | 157 | - | 290 | 273.7 | 11.3 | 205.3 | 5 | 5 | - |
| | 0185H100-4 | 180 | 157 | - | 290 | 273.7 | 11.3 | 205.3 | 5 | 5 | - |
| | 0220H100-4 | 220 | 193.8 | - | 350 | 331 | 13 | 223.2 | 6 | 6 | - |
| | 0300H100-4 | 220 | 193.8 | - | 350 | 331 | 13 | 223.2 | 6 | 6 | - |
| | 0370H100-4 | 275 | 232 | - | 450 | 428.5 | 14 | 284 | 7 | 7 | - |
| | 0450H100-4 | 325 | 282 | - | 510 | 486.5 | 16 | 284 | 7 | 7 | - |
| | 0550H100-4 | 325 | 282 | - | 510 | 486.5 | 16 | 284 | 7 | 7 | - |
| | 0750H100-4 | 325 | 275 | - | 550 | 524.5 | 16 | 309 | 9 | 9 | - |
| | 0900H100-4 | 325 | 275 | - | 550 | 524.5 | 16 | 309 | 9 | 9 | - |
| | 1100H100-4 | 300 | 200 | 240 | 706 | 688.5 | 9.5 | 386 | 9 | 9 | - |
| | 1320H100-4 | 300 | 200 | 240 | 706 | 688.5 | 9.5 | 386 | 9 | 9 | - |
| | 1600H100-4 | 380 | 300 | 300 | 705 | 685.5 | 9.5 | 396 | 9 | 9 | - |
| | 1850H100-4 | 380 | 300 | 300 | 705 | 685.5 | 9.5 | 396 | 9 | 9 | - |
| | 2200H100-4 | 440 | 320 | - | 922.3 | 895.5 | 15.5 | 440 | 11 | 11 | - |
| 2500H100-4 | 440 | 320 | - | 922.3 | 895.5 | 15.5 | 440 | 11 | 11 | - | |
| 3150H100-4 | 600 | 420 | - | 1000 | 972 | 15 | 500 | 14 | 14 | - | |
| 3550H100-4 | 600 | 420 | - | 1000 | 972 | 15 | 500 | 14 | 14 | - | |
| 4000H100-4 | 600 | 420 | - | 1000 | 972 | 15 | 500 | 14 | 14 | - | |
| 5000H100-4 | 776 | 500 | - | 1054 | 1021 | 20 | 500 | 14 | 14 | - | |

Units : inches

Technical Specification

| Items | | W1 | W2 | W3 | H1 | H2 | H3 | D1 | A | B | Φ |
|------------------|------------|-------|-------|-------|-------|-------|-------|-------|------|------|---|
| 3-phase 200 V | 0008H100-2 | 6.30 | 5.39 | - | 9.13 | 8.52 | 0.41 | 7.13 | 0.20 | 0.20 | - |
| | 0015H100-2 | 6.30 | 5.39 | - | 9.13 | 8.52 | 0.41 | 7.13 | 0.20 | 0.20 | - |
| | 0022H100-2 | 6.30 | 5.39 | - | 9.13 | 8.52 | 0.41 | 7.13 | 0.20 | 0.20 | - |
| | 0037H100-2 | 6.30 | 5.39 | - | 9.13 | 8.52 | 0.41 | 7.13 | 0.20 | 0.20 | - |
| | 0055H100-2 | 6.30 | 5.39 | - | 9.13 | 8.52 | 0.41 | 7.13 | 0.20 | 0.20 | - |
| | 0075H100-2 | 6.30 | 5.39 | - | 9.13 | 8.52 | 0.41 | 7.13 | 0.20 | 0.20 | - |
| | 0110H100-2 | 6.30 | 5.39 | - | 9.13 | 8.52 | 0.41 | 7.13 | 0.20 | 0.20 | - |
| | 0150H100-2 | 7.09 | 6.18 | - | 11.42 | 10.78 | 0.45 | 8.08 | 0.20 | 0.20 | - |
| | 0185H100-2 | 8.66 | 7.63 | - | 13.78 | 13.03 | 0.51 | 8.79 | 0.24 | 0.24 | - |
| 3-Phase 400 V | 0008H100-4 | 6.30 | 5.39 | - | 9.13 | 8.52 | 0.41 | 7.13 | 0.20 | 0.20 | - |
| | 0015H100-4 | 6.30 | 5.39 | - | 9.13 | 8.52 | 0.41 | 7.13 | 0.20 | 0.20 | - |
| | 0022H100-4 | 6.30 | 5.39 | - | 9.13 | 8.52 | 0.41 | 7.13 | 0.20 | 0.20 | - |
| | 0037H100-4 | 6.30 | 5.39 | - | 9.13 | 8.52 | 0.41 | 7.13 | 0.20 | 0.20 | - |
| | 0055H100-4 | 6.30 | 5.39 | - | 9.13 | 8.52 | 0.41 | 7.13 | 0.20 | 0.20 | - |
| | 0075H100-4 | 6.30 | 5.39 | - | 9.13 | 8.52 | 0.41 | 7.13 | 0.20 | 0.20 | - |
| | 0110H100-4 | 6.30 | 5.39 | - | 9.13 | 8.52 | 0.41 | 7.13 | 0.20 | 0.20 | - |
| | 0150H100-4 | 7.09 | 6.18 | - | 11.42 | 10.78 | 0.45 | 8.08 | 0.20 | 0.20 | - |
| | 0185H100-4 | 7.09 | 6.18 | - | 11.42 | 10.78 | 0.45 | 8.08 | 0.20 | 0.20 | - |
| | 0220H100-4 | 8.66 | 7.63 | - | 13.78 | 13.03 | 0.51 | 8.79 | 0.24 | 0.24 | - |
| | 0300H100-4 | 8.66 | 7.63 | - | 13.78 | 13.03 | 0.51 | 8.79 | 0.24 | 0.24 | - |
| | 0370H100-4 | 10.83 | 9.13 | - | 17.72 | 16.87 | 0.55 | 11.18 | 0.28 | 0.28 | - |
| | 0450H100-4 | 12.80 | 11.10 | - | 20.08 | 19.15 | 0.63 | 11.18 | 0.28 | 0.28 | - |
| | 0550H100-4 | 12.80 | 11.10 | - | 20.08 | 19.15 | 0.63 | 11.18 | 0.28 | 0.28 | - |
| | 0750H100-4 | 12.80 | 10.83 | - | 21.65 | 20.65 | 0.63 | 12.17 | 0.35 | 0.35 | - |
| | 0900H100-4 | 12.80 | 10.83 | - | 21.65 | 20.65 | 0.63 | 12.17 | 0.35 | 0.35 | - |
| 1100H100-4 | 11.81 | 7.87 | 9.45 | 27.80 | 27.11 | 0.37 | 15.20 | 0.35 | 0.35 | - | |
| 1320H100-4 | 11.81 | 7.87 | 9.45 | 27.80 | 27.11 | 0.37 | 15.20 | 0.35 | 0.35 | - | |
| 1600H100-4 | 14.96 | 11.81 | 11.81 | 27.76 | 26.99 | 0.37 | 15.59 | 0.35 | 0.35 | - | |

| Items | | W1 | W2 | W3 | H1 | H2 | H3 | D1 | A | B | Φ |
|-------|------------|-------|-------|-------|-------|-------|------|-------|------|------|---|
| | 1850H100-4 | 14.96 | 11.81 | 11.81 | 27.76 | 26.99 | 0.37 | 15.59 | 0.35 | 0.35 | - |
| | 2200H100-4 | 17.32 | 12.60 | - | 36.31 | 35.26 | 0.61 | 17.32 | 0.43 | 0.43 | - |
| | 2500H100-4 | 17.32 | 12.60 | - | 36.31 | 35.26 | 0.61 | 17.32 | 0.43 | 0.43 | - |
| | 3150H100-4 | 23.62 | 16.54 | - | 39.37 | 38.27 | 0.59 | 19.69 | 0.55 | 0.55 | - |
| | 3550H100-4 | 23.62 | 16.54 | - | 39.37 | 38.27 | 0.59 | 19.69 | 0.55 | 0.55 | - |
| | 4000H100-4 | 23.62 | 16.54 | - | 39.37 | 38.27 | 0.59 | 19.69 | 0.55 | 0.55 | - |
| | 5000H100-4 | 30.55 | 19.69 | - | 41.50 | 40.20 | 0.79 | 19.69 | 0.55 | 0.55 | - |

11.4 Peripheral Devices

Compatible Circuit Breaker, Leakage Breaker and Magnetic Contactor Models (manufactured by LS ELECTRIC)

⚠ Warning

- Install appropriate branch circuit protection based on required local codes and the user manual.
- The device is suitable for use on a circuit capable of delivering not more than 100kA, 240Vac maximum(200V class) and 480 Vac maximum(400V class) when protected by branch circuit protection devices specified in this manual.

| Product (kW) | Circuit Breaker | | | | Leakage Breaker | | Magnetic Contactor | | |
|------------------|-----------------|---------------|--------|---------------|-----------------|---------------|--------------------|---------------|-----|
| | Model | Rated Current | Model | Rated Current | Model | Rated Current | Model | Rated Current | |
| 3-Phase 200 V | 0.75 | ABS33c | UTE100 | 15 | EBS33c | 15 | MC-9a | 11 | |
| | 1.5 | | | 15 | | 15 | MC-18a | 18 | |
| | 2.2 | | | 30 | | 15 | 30 | MC-32a | 32 |
| | 3.7 | | | 30 | | 15 | 30 | MC-32a | 32 |
| | 5.5 | ABS53c | UTE100 | 50 | EBS53c | 50 | MC-50a | 55 | |
| | 7.5 | ABS63c | | 60 | EBS63c | 60 | MC-65a | 65 | |
| | 11 | ABS103c | | 100 | EBS103c | 100 | MC-85a | 85 | |
| | 15 | | | 100 | | | 100 | MC-130a | 130 |
| 18.5 | ABS203c | 150 | UTS150 | 150 | EBS203c | 200 | MC-150a | 150 | |

Technical Specification

| Product (kW) | | Circuit Breaker | | | | Leakage Breaker | | Magnetic Contactor | |
|------------------|---------|-----------------|---------------|--------|---------------|-----------------|---------------|--------------------|---------------|
| | | Model | Rated Current | Model | Rated Current | Model | Rated Current | Model | Rated Current |
| 3-Phase 400 V | 0.75 | ABS33c | 10 | UTE100 | 15 | EBS33C | 10 | MC-6a | 9 |
| | 1.5 | | 10 | | 15 | | 10 | MC-6a | 9 |
| | 2.2 | | 15 | | 15 | | 15 | MC-9a | 11 |
| | 3.7 | | 15 | | 15 | | 15 | MC-12a | 13 |
| | 5.5 | ABS53c | 50 | UTE100 | 50 | EBS33C | 30 | MC-22b | 22 |
| | 7.5 | | 50 | | 50 | | 30 | MC-32a | 32 |
| | 11 | ABS63c | 60 | UTE100 | 60 | EBS53c | 50 | MC-50a | 50 |
| | 15 | ABS63c | 60 | | 80 | EBS63c | 60 | MC-65a | 65 |
| | 18.5 | ABS103c | 100 | | 100 | EBS103c | 100 | MC-85a | 85 |
| | 22 | ABS103c | 125 | UTS150 | 125 | | 125 | MC-100a | 105 |
| | 30 | ABS103c | 125 | | 125 | 125 | MC-130a | 130 | |
| | 37 | ABS203c | 175 | UTS250 | 175 | EBS203c | 200 | MC-150a | 150 |
| | 45 | ABS203c | 225 | | 225 | | 225 | MC-185a | 185 |
| | 55 | ABS203c | 250 | | 250 | | 250 | MC-185a | 185 |
| | 75 | ABS403c | 300 | UTS400 | 300 | EBS403C | 300 | MC-225a | 225 |
| | 90 | ABS403c | 350 | | 350 | | 350 | MC-330a | 330 |
| | 110 | ABS603c | 500 | UTS600 | 500 | EBS603c | 500 | MC-400a | 400 |
| | 132 | ABS603c | 600 | | 600 | EBS603c | 630 | MC-400a | 400 |
| | 160 | ABS603c | 630 | | 600 | EBS603c | 630 | MC-630a | 630 |
| | 185 | ABS803c | 800 | UTS800 | 800 | EBS803c | 800 | MC-630a | 630 |
| 220 | ABS803c | 800 | 800 | | EBS803c | 800 | MC-800a | 800 | |
| 250 | ABS1003 | 1000 | 800 | | EBS1003 | 1000 | MC-800a | 800 | |
| 315 | ABS1203 | 1200 | UTS1200 | 1200 | EBS1203 | 1200 | 1200a | 1200 | |
| 355 | ABS1203 | 1200 | | 1200 | EBS1203 | 1200 | 1200a | 1200 | |
| 400 | - | 1600 | - | 1600 | | | | | |
| 500 | - | 1600 | - | 1600 | | | | | |
| 3-Phase | 110 | ABS603c | 500 | UTS600 | 500 | EBS603c | 500 | MC-400a | 400 |
| | 132 | ABS603c | 600 | | 600 | EBS603c | 630 | MC-400a | 400 |

| Product (kW) | | Circuit Breaker | | | | Leakage Breaker | | Magnetic Contactor | |
|--------------|-----|-----------------|---------------|---------|---------------|-----------------|---------------|--------------------|---------------|
| | | Model | Rated Current | Model | Rated Current | Model | Rated Current | Model | Rated Current |
| 500V | 160 | ABS603c | 630 | | 600 | EBS603c | 630 | MC-630a | 630 |
| | 185 | ABS803c | 800 | UTS800 | 800 | EBS803c | 800 | MC-630a | 630 |
| | 220 | ABS803c | 800 | | 800 | EBS803c | 800 | MC-800a | 800 |
| | 250 | ABS803c | 800 | | 800 | EBS803c | 800 | MC-800a | 800 |
| | 315 | ABS1203b | 1200 | UTS1200 | 1200 | EBS1203 | 1200 | 1200a | 1200 |
| | 355 | ABS1203b | 1200 | | 1200 | EBS1203 | 1200 | 1200a | 1200 |
| | 400 | - | 1600 | - | 1600 | - | - | - | - |
| | 500 | - | 1600 | - | 1600 | - | - | - | - |

* In the case of inverter 400/500 kW, there is no Circuit Brake capacity qualified as UL standard.
 * If you want to use UL Type products, please use that ACB product.

Maximum allowed prospective short-circuit current at the input power connection is defined in IEC 60439-1 as 100 kA. LSLV-H100 is suitable for use in a circuit capable of delivering not more than 100kA RMS at the drive's maximum rated voltage, depending on the selected MCCB. RMS symmetrical amperes for recommended MCCB are the following table.

| Working Voltage | UTE100 (E/N) | | UTS150 (N/H/L) | | UTS250 (N/H/L) | | UTS400 (N/H/L) | |
|-----------------|--------------|--------|----------------|---------|----------------|---------|----------------|--|
| 240V(50/60Hz) | 50/65kA | | 65/100/150kA | | 65/100/150kA | | 65/100/150kA | |
| 480V(50/60Hz) | 25/35kA | | 35/65/100kA | | 35/65/100kA | | 35/65/100kA | |
| Working Voltage | ABS33c | ABS53c | ABS63c | ABS103c | ABS203c | ABS403c | | |
| 240V(50/60Hz) | 30kA | 35kA | 35kA | 85kA | 85kA | 75kA | | |
| 480V(50/60Hz) | 7.5kA | 10kA | 10kA | 26kA | 26kA | 35kA | | |

11.5 Fuse and Reactors Specifications

| Products(kW) | | AC Input Fuse | | AC reactor | | DC Reactor | |
|------------------|------|---------------|-------------|-----------------|-------------|-----------------|-------------|
| | | Current (A) | Voltage (V) | Inductance (mH) | Current (A) | Inductance (mH) | Current (A) |
| 3-Phase 200 V | 0.75 | 10 | 600[V] | 2.02 | 5 | 4.04 | 5 |
| | 1.5 | 10 | | 1.26 | 8 | 2.53 | 8 |
| | 2.2 | 15 | | 0.78 | 12 | 1.68 | 12 |
| | 3.7 | 20 | | 0.59 | 16 | 1.26 | 16 |
| | 5.5 | 50 | | 0.43 | 24 | 0.93 | 25 |
| | 7.5 | 63 | | 0.31 | 33 | 0.73 | 32 |
| | 11 | 80 | | 0.22 | 46 | 0.53 | 50 |
| | 15 | 100 | | 0.16 | 62 | 0.32 | 62 |
| | 18.5 | 125 | | 0.13 | 77 | 0.29 | 80 |
| 3-Phase 400 V | 0.75 | 10 | | 8.09 | 2.5 | 16.17 | 3 |
| | 1.5 | 10 | | 5.05 | 4 | 10.11 | 4 |
| | 2.2 | 15 | | 3.37 | 6 | 6.74 | 6 |
| | 3.7 | 20 | | 2.25 | 9 | 5.05 | 8 |
| | 5.5 | 32 | | 1.56 | 13 | 3.56 | 13 |
| | 7.5 | 35 | | 1.16 | 17 | 2.53 | 18 |
| | 11 | 50 | | 0.76 | 27 | 1.64 | 26 |
| | 15 | 63 | | 0.61 | 33 | 1.42 | 33 |
| | 18.5 | 70 | | 0.48 | 43 | 0.98 | 42 |
| | 22 | 100 | | 0.40 | 51 | 0.88 | 50 |
| | 30 | 125 | 0.29 | 69 | 0.59 | Built-In | |
| | 37 | | 0.29 | 69 | | | |
| | 45 | 160 | 0.24 | 85 | | | |
| | 55 | 200 | 0.20 | 100 | | | |
| | 75 | 250 | 0.15 | 134 | | | |
| | 90 | 350 | 0.13 | 160 | | | |
| | 110 | 350 | 0.1 | 217 | | | |
| 132 | 400 | 0.08 | 257 | | | | |
| 160 | 450 | 0.07 | 318 | | | | |

| Products(kW) | AC Input Fuse | | AC reactor | | DC Reactor | |
|--------------|---------------|-------------|-----------------|-------------|-----------------|-------------|
| | Current (A) | Voltage (V) | Inductance (mH) | Current (A) | Inductance (mH) | Current (A) |
| 185 | 550 | | 0.06 | 362 | | |
| 220 | 630 | | 0.05 | 423 | | |
| 250 | 700 | | 0.05 | 474 | | |
| 315 | 800 | | 0.04 | 604 | | |
| 355 | 1000 | | 0.03 | 673 | | |
| 400 | 1100 | | 0.03 | 759 | | |
| 500 | 1250 | | 0.03 | 948 | | |

⚠ Caution

Use Class H or RK5 UL Listed Input Fuse and UL Listed Breaker Only. See the table above for the Voltage and Current rating of the fuse and the breaker.

Attention

Utiliser UNIQUEMENT des fusibles d'entrée homologués de Classe H ou RK5 UL et des disjoncteurs UL . Se reporter au tableau ci-dessus pour la tension et le courant nominal des fusibles et des disjoncteurs.

11.6 Terminal Screw Specifications

Input/Output Terminal Screw Specification

| Product (kW) | Terminal Screw Size | Screw Torque (Kgf·c m/Nm) |
|------------------|---------------------|-----------------------------------|
| 3-Phase 200 V | 0.75 | M4 12.2 ~ 14.3 / 1.2 ~ 1.4 |
| | 1.5 | |
| | 2.2 | |
| | 3.7 | |
| | 5.5 | |
| | 7.5 | |
| | 11 | |
| | 15 | M5 20.4 ~ 24.5 / 2.0 ~ 2.4 |
| 18.5 | | |

| Product (kW) | | Terminal Screw Size | Screw Torque (Kgf·c m/Nm) |
|------------------|--------------------|---|-------------------------------|
| 3-Phase 400 V | 0.75 | M4 | 12.2 ~ 14.3 / 1.2 ~ 1.4 |
| | 1.5 | | |
| | 2.2 | | |
| | 3.7 | | |
| | 5.5 | | |
| | 7.5 | | |
| | 11 | | |
| | 15 | M5 | 20.4 ~ 24.5 / 2.0 ~ 2.4 |
| | 18.5 | | |
| | 22 | | |
| | 30 | | |
| | 37 | M8 | 56.12 ~ 67.3 / 5.5 ~ 6.6 |
| | 45 | | |
| | 55 | | |
| | 75 | | |
| | 90 | | |
| | 110 | M10 | 89.7 ~ 122.0 / 8.8 ~ 11.96 |
| | 132 | | |
| | 160 | M12 | 182.4 ~ 215.0 / 17.87 ~ 21.07 |
| | 185 | | |
| 220 | | | |
| 250 | | | |
| 315 | M8 X 2 M12 X 1 | 61.2 ~ 91.8 / 6 ~ 9 182.4 ~ 215.0 / 17.87 ~ 21.07 | |
| 355 | | | |
| 400 | | | |
| 500 | M10 X 2 M16 X 1 | 89.7 ~ 122.0 / 8.8 ~ 11.96 490.9 ~ 511.0 / 48.05 ~ 50.11 | |

Control Circuit Terminal Screw Specification

| Terminal | Terminal Screw Size | Screw Torque(Kgf·cm/Nm) |
|---|---------------------|-------------------------|
| P1-P7/ CM/VR/V1/I2/AO/Q1/EG/24/ TI/TO/SA,SB,SC/S+,S-,SG A1/B1/C1 | M3 | 2.2 ~ 2.5 / 0.22 ~ 0.25 |

⚠ Caution

Apply rated torques to the terminal screws. Loose screws may cause short circuits and malfunctions. Tightening the screw too much may damage the terminals and cause short circuits and malfunctions. Use copper wires only with 600 V, 90 °C rating for the power terminal wiring, and 300 V, 75 °C rating for the control terminal wiring.

Attention

Appliquer des couples de marche aux vis des bornes. Des vis desserrées peuvent provoquer des courts-circuits et des dysfonctionnements. Ne pas trop serrer la vis, car cela risque d'endommager les bornes et de provoquer des courts-circuits et des dysfonctionnements. Utiliser uniquement des fils de cuivre avec une valeur nominale de 600 V, 90 °C pour le câblage de la borne d'alimentation, et une valeur nominale de 300 V, 75 °C pour le câblage de la borne de commande.

11.7 Dynamic breaking unit (DBU) and Resistors

11.7.1 Dynamic breaking unit (DBU)

| UL form | Type | Voltage | Capacity of applied motor | Braking unit | Terminal arrangement & Dimensions |
|---------|--|---------|---------------------------|-------------------|-------------------------------------|
| UL type | Type A (Resistance of DB Resistor refer to the table of "11.7.6 DB Resistors") | 200V | 30, 37 kW | SV370DBU-2U | Refer to the appearance of Group 1. |
| | | | 45, 55 kW | SV550DBU-2U | |
| | | | 75 kW | SV370DBU-2U, 2Set | |
| | | 400V | 30, 37 kW | SV370DBU-4U | |
| | | | 45, 55 kW | SV550DBU-4U | |
| | | | 75 kW | SV750DBU-4U | |
| | | | 90 kW | SV550DBU-4U, 2Set | |
| | | | 110, 132kW | SV750DBU-4U, 2Set | |
| 160kW | SV750DBU-4U, 3Set | | | | |

| | | | | | |
|-------------|--|-----------------------|-----------------------|-----------------|------------------------------------|
| Non UL type | Type B (Resistance of DB Resistor refer to the manual of DB Unit) | 200V | 30, 37 kW | SV037DBH-2 | Refer to the appearance of Group 2 |
| | | 400V | 30, 37 kW | SV037DBH-4 | |
| | | | 45, 55, 75 kW | SV075DBH-4 | |
| | | | | SV075DB-4 | Refer to the appearance of Group 3 |
| | | | 185, 220kW | SV2200DB-4 | Refer to the appearance of Group 4 |
| | 250~355kW | SV2200DB-4, 2Set | | | |
| | Type C (Resistance of DB Resistor refer to the manual of DB Unit) | 200V | 30, 37 kW | LSLV0370DBU-2LN | Refer to the appearance of Group 5 |
| | | | | LSLV0370DBU-2HN | Refer to the appearance of Group 6 |
| | | | 45, 55, 75 kW | LSLV0750DBU-2LN | Refer to the appearance of Group 5 |
| | | | | LSLV0750DBU-2HN | Refer to the appearance of Group 6 |
| | | 400V | 30, 37 kW | LSLV0370DBU-4LN | Refer to the appearance of Group 5 |
| | | | | LSLV0370DBU-4HN | Refer to the appearance of Group 6 |
| | | | 45, 55, 75kW | LSLV0750DBU-4LN | Refer to the appearance of Group 5 |
| | | | 90 kW | LSLV0900DBU-4HN | Refer to the appearance of Group 6 |
| | | | 110, 132kW | LSLV1320DBU-4HN | |
| | | | 160kW | LSLV1600DBU-4HN | |
| | | | 185, 220kW | LSLV2200DBU-4HN | |
| | | 250~355kW | LSLV2200DBU-4HN, 2Set | | |
| 400, 500kW | | LSLV2200DBU-4HN, 2Set | | | |

Note

- It is not necessary to use option type dynamic braking unit for H100 0.75~18.5kW(200V) and 0.75~30kW(400V) because basically the dynamic braking unit is built in.
- You must refer to dynamic braking unit manual for usage recommended dynamic braking unit in the table above due to changeable table.
- Resistance/watt/breaking torque/%ED of DB Resistor for Type A DB Unit refer to the table of "11.7.6 DB Resistors" and Resistance of DB Resistor for type B and C refer to the manual of DB Unit.

11.7.2 Terminal arrangement



| Terminals | Functions |
|-----------|---|
| G | Ground Terminal |
| B2 | Terminal for connection with B2 of DBU |
| B1 | Terminal for connection with B1 of DBU |
| N | Terminal for connection with N of Inverter |
| P | Terminal for connection with P1 of Inverter |

* Note: READ DBU User manual certainly when selecting DB resistors.

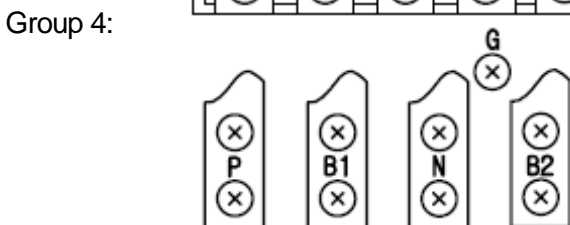
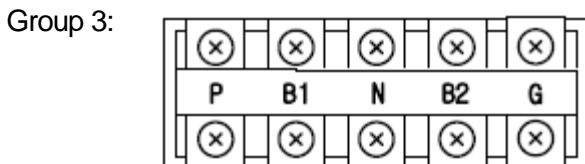

| Terminals | Functions |
|-----------|--|
| G | Ground Terminal |
| B2 | Terminal for connection with B2 of DBU |
| B1 | Terminal for connection with B1 of DBU |
| N | Terminal for connection with N of Inverter |
| P | Terminal for connection with P of Inverter |

Group 5:

P(+) N(-) B1 B2 N.C E

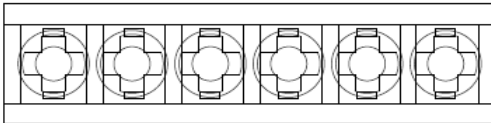

| Terminals | Functions |
|-----------|--|
| P(+) | Terminal for connection with P of Inverter |
| N(-) | Terminal for connection with N of Inverter |
| B1 | Terminal for connection with B1 of DBU |
| B2 | Terminal for connection with B2 of DBU |
| N.C | Unused |
| E | Ground Terminal |

Group6:

A Frame (37kW, 75kW-4)

P(+) N(-) B1 B2 N.C E

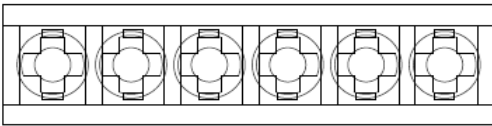

B/C Frame (75kW-2, 90~220kW)

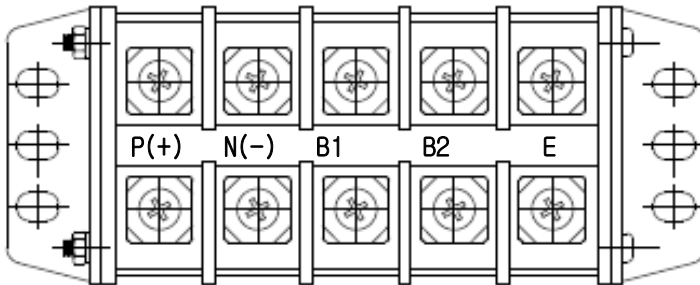

| Terminals | Functions |
|-----------|--|
| P(+) | Terminal for connection with P of Inverter |
| N(-) | Terminal for connection with N of Inverter |
| B1 | Terminal for connection with B1 of DBU |
| B2 | Terminal for connection with B2 of DBU |
| E | Unused |

Note

You must refer to dynamic braking unit manual for choice the braking resistor to use the dynamic braking unit.

11.7.3 Dynamic Breaking (DB)Unit & DB resistor basic wiring

0.75~90kW

110~500kW

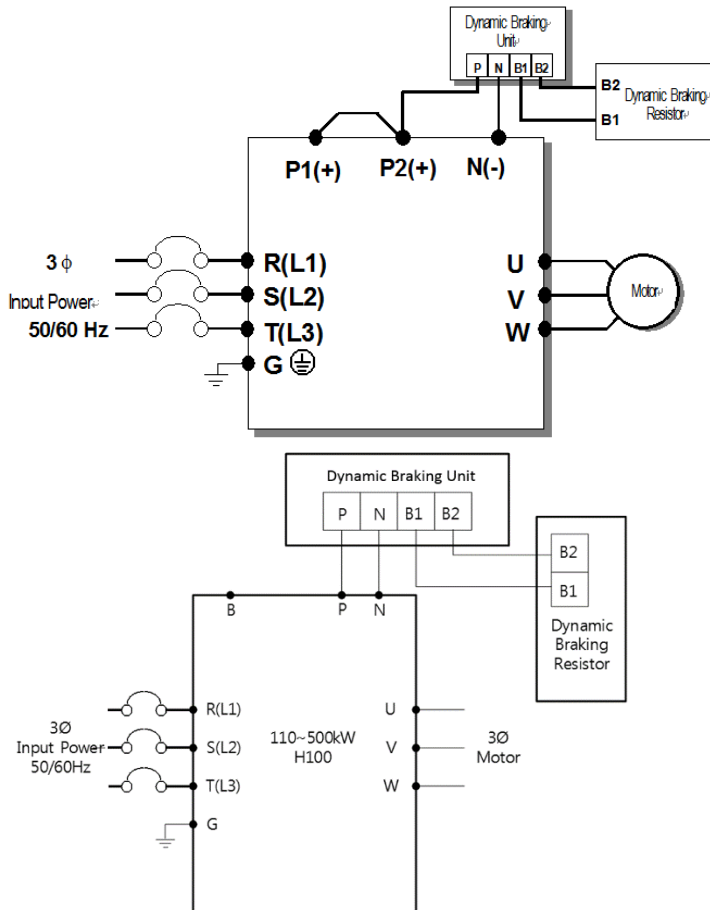

| DBU Terminals | Description |
|---------------|--|
| B1,B2 | Wire correctly referring to wiring diagram. DB Resistors connect with B1, B2 of DB Unit. |

In case of large capacity, it may be necessary to connect more than 2 sets of DB Unit according to the usage environment.

In such cases, check the DB Unit manual.

11.7.4 Dimensions

-Group1

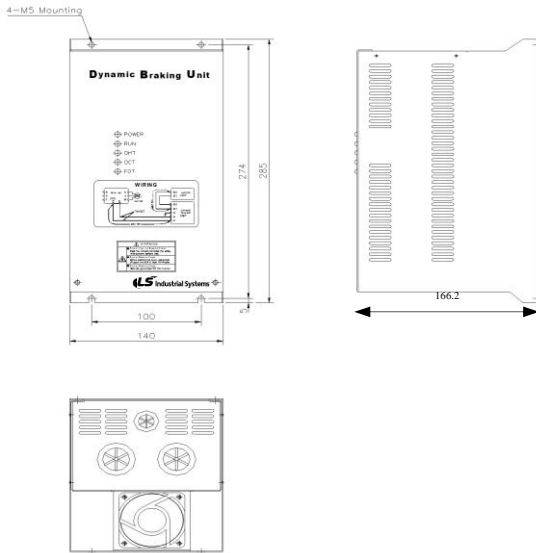

- Group2

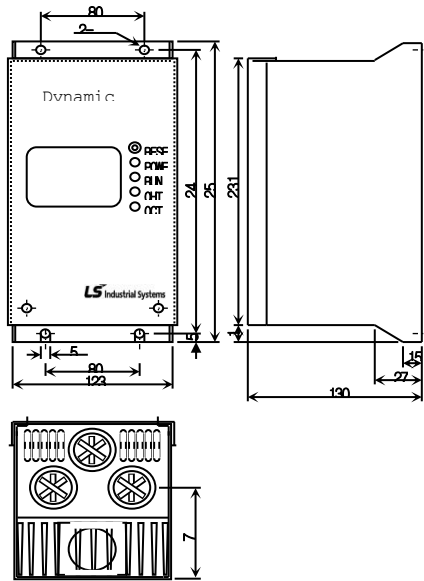

-Group3

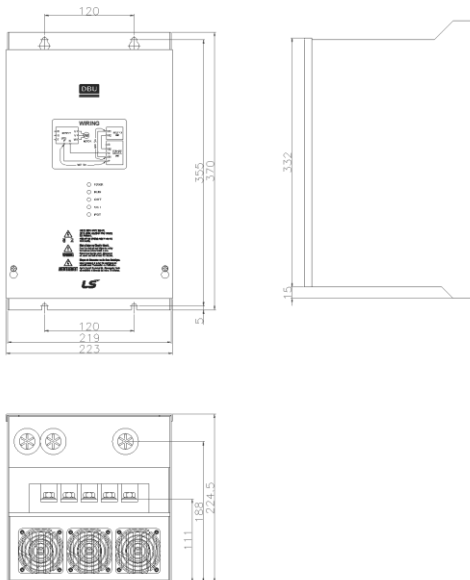

- Group4

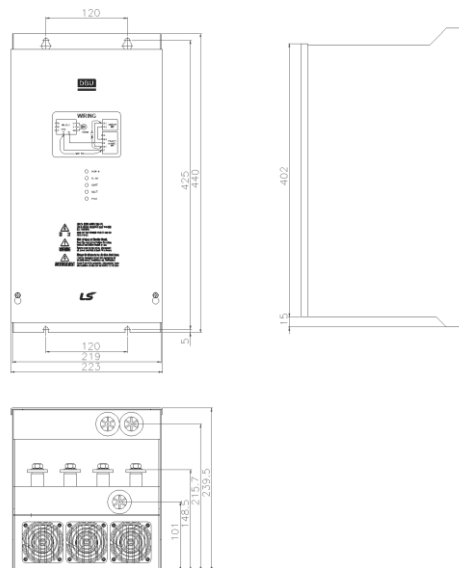

- Group5

Technical Specification

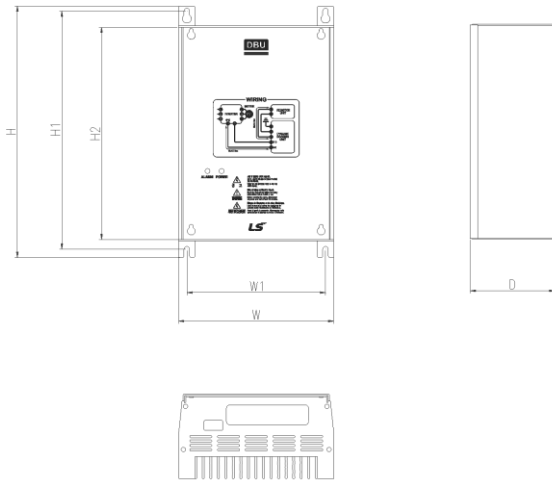

| Voltage | Capacity of applied motor | Dimension (mm) | | | | Hole position for installation (mm) | | Weight | Hole size for installation |
|---------|---------------------------|----------------|-------|-----|------|-------------------------------------|-------|--------|----------------------------|
| | | W | H | H2 | D | W1 | H1 | | |
| 220 | 15 | 140 | 227.4 | 192 | 76.4 | 125 | 215.4 | 1.50 | M4 |
| | 22 | | | | | | | 1.55 | |
| | 37 | | | | | | | 1.57 | |
| | 75 | | | | | | | 1.84 | |
| 440 | 15 | | | | | | | 1.53 | |
| | 22 | | | | | | | 1.55 | |
| | 37 | | | | | | | 1.56 | |
| | 75 | | | | | | | 1.85 | |

- Group6

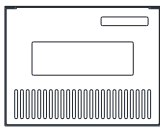
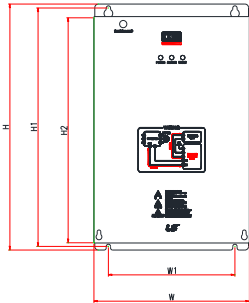
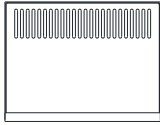

| F R A M E | Volta ge | Capacit y of applied motor | % E D | Dimension (mm) | | | | Hole position for installation (mm) | | Weig ht (Kg) | Hole size for installati on (φ) |
|-----------------------|-------------|-------------------------------------|-------------|----------------|-----|-----|-------|--|-------|------------------------|---|
| | | | | W | H | H2 | D | W1 | H1 | | |
| A Fra me | 220 [V] | 37 [kW] | 50 | 200 | 219 | 190 | 165.2 | 160 | 208.5 | 3.77 | M6 |
| | 440 [V] | 37 [kW] | 50 | | | | | | | 3.84 | |
| | | 75 [kW] | 50 | | | | | | | 3.98 | |
| B Fra me | 220 [V] | 75 [kW] | 50 | 215 | 340 | 311 | 165.2 | 175 | 329.5 | 8.26 | |
| | | 90 [kW] | 50 | | | | | | | 8.48 | |
| | 440 [V] | 90 [kW] | 50 | | | | | | | 8.30 | |
| | | 132 [kW] | 50 | | | | | | | 8.40 | |
| C Fra me | 440 [V] | 160 [kW] | 50 | 240 | 380 | 351 | 165.2 | 200 | 369.5 | 9.40 | |
| | | 220 [kW] | 50 | | | | | | | 9.70 | |

11.7.5 Display Functions

DB Resistors connect with B1, B2 of DB Unit. DBU has 3 LEDs. Red LED which is located in middle displays supplying main power, one Green LED which is right side displays under breaking and another green LED which is left side displays Over Heat Trip(OHT).

| Displays | Function description |
|--------------------|---|
| POWER (Red LED) | POWER LED is turned On when main power is supplied. Generally, POWER LED is turn On while main power supplied because DBU is connected with inverter. |
| RUN (Green LED) | RUN LED is turned off while DBU is ON by regenerative energy of Motor. |
| OHT (Green LED) | Under Breaking, if the temperature is exceeded over setting value due to over heat of Heatsink, Cut the TURN ON signal of DBU and LED is turn on by working overheat protection function. |

11.7.6 DB Resistors

| Product (kW) | DB unit | Torque 100% | | | Torque 150% | | | |
|----------------------|---------|-----------------|----------------------------|-----------------------------|-----------------|----------------------------|-----------------------------|------|
| | | Resistor (Ω) | Wattage [W] (%ED=5%) | Wattage [W] (%ED=10%) | Resistor (Ω) | Wattage [W] (%ED=5%) | Wattage [W] (%ED=10%) | |
| 3- Phase 200 V | 0.75 | - | 200 | 100 | 200 | 150 | 150 | 300 |
| | 1.5 | - | 100 | 200 | 400 | 60 | 300 | 600 |
| | 2.2 | - | 60 | 300 | 600 | 50 | 400 | 800 |
| | 3.7 | - | 40 | 500 | 1000 | 33 | 600 | 1200 |
| | 5.5 | - | 33 | 600 | 1200 | 20 | 800 | 1600 |
| | 7.5 | - | 20 | 800 | 1600 | 15 | 1200 | 2400 |
| | 11 | - | 15 | 1200 | 2400 | 10 | 2400 | 4800 |
| | 15 | - | 10 | 2400 | 4800 | 8 | 2400 | 4800 |
| | 18.5 | - | 8 | 2400 | 4800 | 6 | 2600 | 5200 |
| 3- Phase 400 V | 0.75 | - | 900 | 100 | 200 | 600 | 150 | 300 |
| | 1.5 | - | 450 | 200 | 400 | 300 | 300 | 600 |
| | 2.2 | - | 300 | 300 | 600 | 200 | 400 | 800 |
| | 3.7 | - | 200 | 400 | 800 | 130 | 600 | 1200 |
| | 5.5 | - | 120 | 700 | 1400 | 85 | 1000 | 2000 |
| | 7.5 | - | 90 | 1000 | 2000 | 60 | 1200 | 2400 |
| | 11 | - | 60 | 1200 | 2400 | 40 | 2000 | 4000 |

| Product (kW) | DB unit | Torque 100% | | | Torque 150% | | |
|--------------|---|--------------|-------------------------|--------------------------|--------------|-------------------------|--------------------------|
| | | Resistor (Ω) | Wattage [W] (%ED=5%) | Wattage [W] (%ED=10%) | Resistor (Ω) | Wattage [W] (%ED=5%) | Wattage [W] (%ED=10%) |
| 15 | | 45 | 2000 | 4000 | 32 | 2400 | 4800 |
| 18.5 | - | 35 | 2400 | 4800 | 20 | 3600 | 7200 |
| 22 | - | 30 | 2400 | 4800 | 20 | 3600 | 7200 |
| 30 | - | 20 | 3600 | 7200 | 16 | 5000 | 10000 |
| 37 | DBU-U | 16.9 | 3200 | 6400 | - | - | - |
| | DBH | 16.9 | 3200 | 6400 | 12 | 5000 | 10000 |
| | LSLV-DB | 16.9 | 3200 | 6400 | 12 | 5000 | 10000 |
| 45 | DBU-U | 11.4 | 4800 | 9600 | - | - | - |
| | DBH | 11.4 | 4800 | 9600 | 10 | 6400 | 12800 |
| | LSLV-DB | 11.4 | 4800 | 9600 | 10 | 6400 | 12800 |
| 55 | DBU-U | 11.4 | 4800 | 9600 | - | - | - |
| | DBH | 11.4 | 4800 | 9600 | 8.4 | 7200 | 14400 |
| | LSLV-DB | 11.4 | 4800 | 9600 | 8.4 | 7200 | 14400 |
| 75 | DBU-U | 8.4 | 6400 | 12800 | - | - | - |
| | DBH | 8.4 | 6400 | 12800 | 6 | 10000 | 20000 |
| | DB | 8.4 | 6400 | 12800 | 6 | 10000 | 20000 |
| 90 | LSLV-DB | 6 | 10000 | 20000 | 5 | 13000 | 26000 |
| 110 | LSLV-DB | 5 | 13000 | 26000 | 4 | 16000 | 32000 |
| 132 | LSLV-DB | 4 | 16000 | 32000 | 3.4 | 20000 | 40000 |
| 160 | LSLV-DB | 3.4 | 20000 | 40000 | 2.8 | 24000 | 48000 |
| 185 | LSLV-DB | 2.8 | 24000 | 48000 | 2.4 | 26000 | 52000 |
| 220 | LSLV-DB | 2.4 | 26000 | 52000 | 2 | 30000 | 60000 |
| 250 | 132kW DB Unit and Resistor * 2 Set (Parallel) | | | | | | |
| 315 | 160kW DB Unit and Resistor * 2 Set (Parallel) | | | | | | |
| 355 | 185kW DB Unit and Resistor * 2 Set (Parallel) | | | | | | |
| 400 | 220kW DB Unit and Resistor * 2 Set (Parallel) | | | | | | |
| 500 | 185kW DB Unit and Resistor * 3 Set (Parallel) | | | | | | |

Note

- It is not necessary to use option type dynamic braking unit for H100 0.75~18.5kW(200V) and 0.75~30kW(400V) because basically the dynamic braking unit is built in.
- The resistance/rated capacity/breaking torque/%ED of DB Resistor are valid only for the DB unit of type A and the values of DB Resistor for type B and C refer to the manual of DB Unit..
- Rating Watt of DBU has to be doubled when %ED is doubled.

11.8 Inverter Continuous Rated Current Derating

Derating by carrier frequency

The continuous rated current of the inverter is limited based on the carrier frequency. Refer to the following graph.

<200[V], 0.75[kW]–18.5[kW], 400[V] 0.75–30[kW] Current Derating Rate>

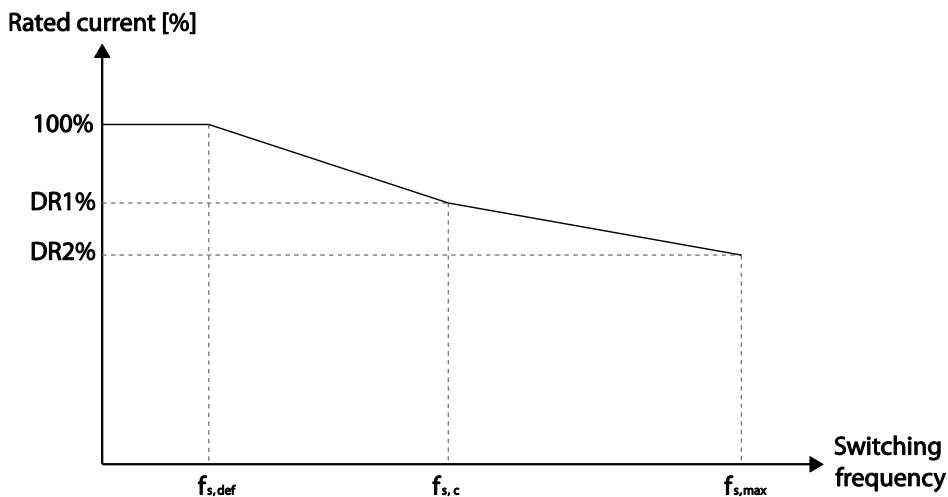

<400[V] 37–500[kW] Current Derating Rate >

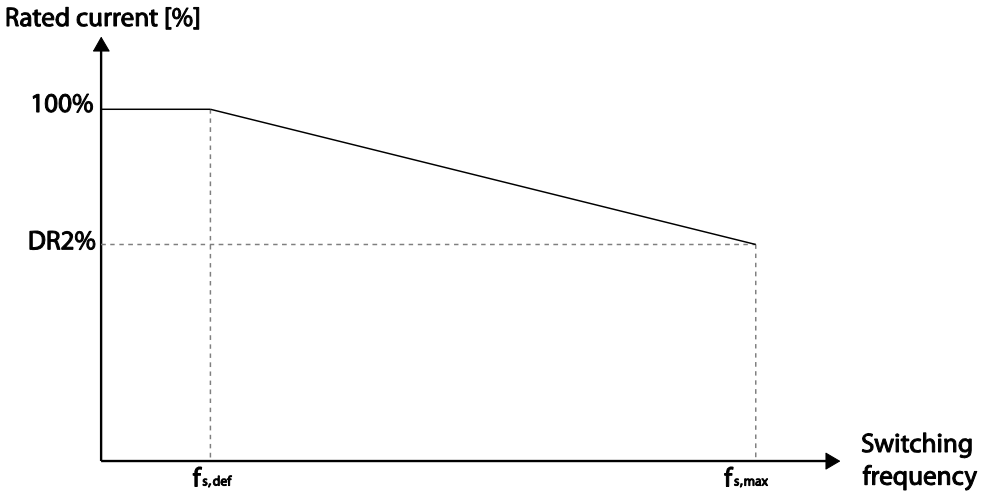

| Item | Unit | 200 V | 400 V | | | | | | |
|-------------|------|--------------|--------------|----------|----------|----------|------------|--------|--------|
| | | 0.75–18.5 kW | 0.75–18.5 kW | 22–30 kW | 37–55 kW | 75–90 kW | 110–355 kW | 400 kW | 500 kW |
| $f_{s,def}$ | kHz | 3 | 3 | 3 | 3 | 3 | 2 | 1.5 | 1.5 |
| $f_{s,c}$ | kHz | 8 | 8 | 8 | - | - | - | 2 | 4 |
| $f_{s,max}$ | kHz | 15 | 15 | 15 | 10 | 7 | 5 | 4 | 4 |
| DR1 % | % | 70 | 65 | 65 | - | - | - | 95 | 92 |
| DR2 % | % | 60 | 55 | 50 | 60 | 55 | 76 | 75 | 65 |

* $f_{s,def}$: Switching frequency for continued operation

$f_{s,c}$: Switching frequency where the first current derating ends.

$f_{s,max}$: The maximum switching frequency (where the second current derating begins)

Derating by Input Voltage

The continuous rated current of the inverter is limited based on the input voltage. Refer to the following graph.

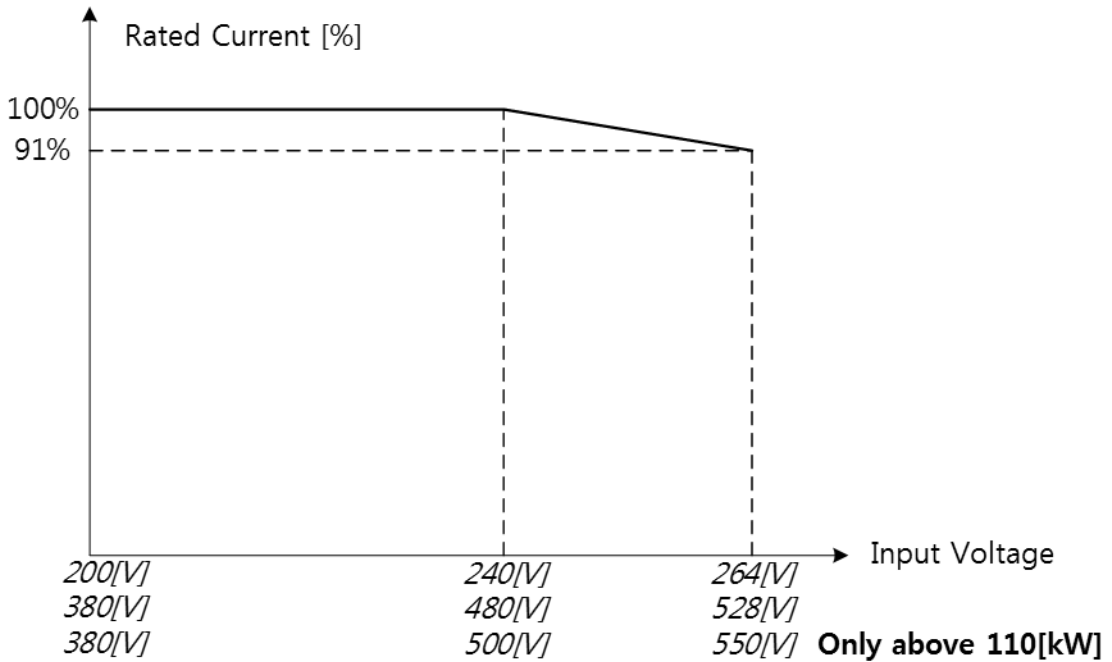

Derating by Ambient Temperature and Installation Type

Ambient temperature and installation type determine the constant-rated current of the inverter. Refer to the following graph. A 2.5% current derating is applied during operation when the ambient temperature is above 40°C. The inverter must be operated at less than 75% of its rated capacity when the ambient temperature is above 50°C.

12 Applying Drives to Single-phase Input Application

12.1 Introduction

LSLV-H100 is a three-phase standard variable frequency drive(VFD). When applying single-phase power to a three-phase VFD, there are several constraints that need to be considered. Standard Pulse-Width-Modulated (PWM) VFDs use a 6-pulse diode rectifier. The 6-pulse rectification results in 360 Hz DC bus ripple when used with a three-phase 60 Hz supply.

However, under single-phase use, the DC bus ripple becomes 120 Hz and the VFDs DC bus circuit is subject to higher stress in order to deliver equivalent power.

Additionally, input currents and harmonics increase beyond those encountered with three-phase input.

Input current distortion of 90% THD and greater can be expected under single-phase input, compared to approximately 40% with three-phase input as indicated in Figure 2.

Therefore, single-phase use requires the three-phase VFD power rating be reduced (derated) to avoid over stressing the rectifier and DC link components.

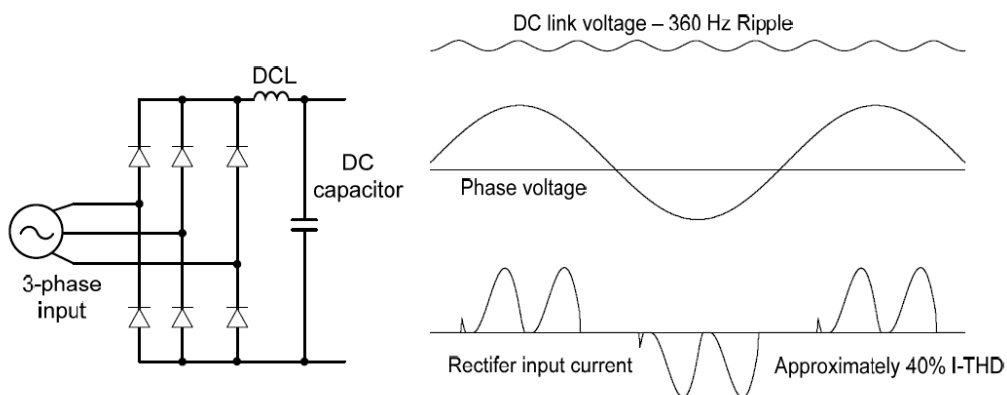

Figure-1 Typical Three-Phase Configuration

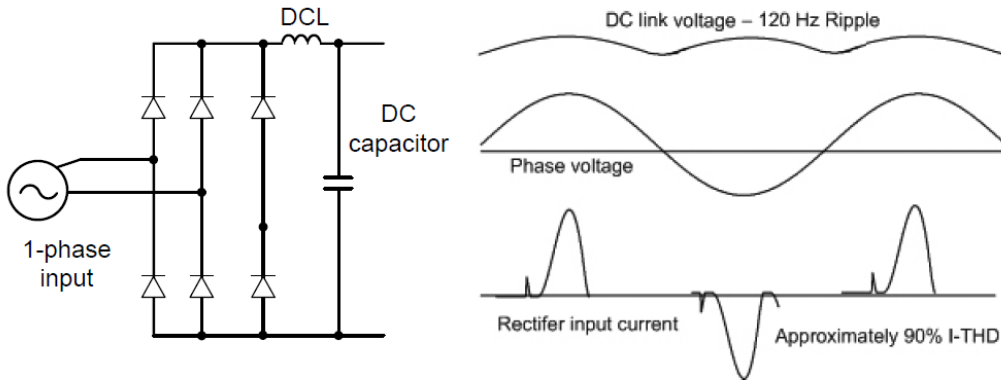

Figure-2 Typical Single-Phase Configuration

12.2 Power(HP), Input Current and Output Current

When using a three-phase VFD with single-phase input, derating the drive's output current and horsepower will be necessary because of the increase in DC bus ripple voltage and current.

In addition, the input current through the remaining two phases on the diode bridge converter will approximately double, creating another derating consideration for the VFD. Input current harmonic distortion will increase beyond that with a three-phase supply making the overall input power factor low. Input current distortion over 100% is likely under single-phase conditions without a reactor.

Therefore, the reactor is always required. When using a motor that is selected by the three-phase drive rating criteria when using single-phase input, it may result in poor performance, premature drive failure. The selected drive of single-phase current ratings must meet or exceed the motor current rating.

In case of single-phase input, the rating of the inverter is smaller than that of the motor. Please check the rating table of 11.1.

12.3 Input Frequency and Voltage Tolerance

The single-phase current ratings are valid for 60Hz input only.

For single-phase input AC voltage, products with 90 kW or less are within -5% to + 10% of 240/480 Vac. Products with 110 kW or more are in the range of -5% to + 10% of 380/500 Vac. Standard product with three-phase voltage input has an allowable range of +10% to – 15%. Therefore, a stricter input voltage tolerance of +10 to –5% applies when using the drive with a single-phase supply. The average bus voltage with single-phase input is lower than the equivalent of a three-phase input.

Therefore, the maximum output voltage (motor voltage) will be lower with a single-phase input. The minimum input voltage must be no less than 228Vac for 240 volt models and 456Vac for 480 volt models, to ensure motor voltage production of 207Vac and 415Vac, respectively.

Thus, if full motor torque must be developed near base speed (full power) it will be necessary to maintain a rigid incoming line voltage so that adequate motor voltage can be produced. Operating a motor at reduced speed (reduced power), or using a motor with a base voltage that is lower than the incoming AC supply rating (ex. 208Vac motor with a 240Vac supply), will also minimize the effect of voltage deprivation. (240VAC Input 208V motor, 480VAC Input 400V motor)

12.4 Wiring

Please connect single-phase input to R(L1) and T(L3).

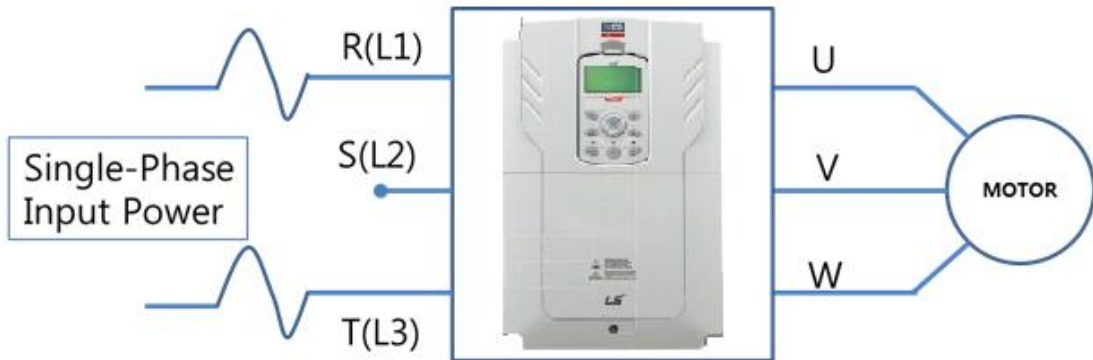

Figure-3 Terminal Wiring Diagram

12.5 Precautions for 1-phase input to 3-phase drive

- Please connect single-phase input to R(L1) and T(L3).
- AC or DC reactor is necessary to reduce DC ripple. Please select built-in reactor type for 37~500kW. For 0.75~30kW, external AC or DC reactor should be installed.
- Same peripheral devices (including a fuse and reactor) as 3 phases can be used for single phase as well.
- If phase open trip occurs, please turn off the input phase open protection(PRT-05).
- Protection for output current like OCT or IOLT is based on 3-phase input ratings which is larger than single-phase input. User should set the parameters that are relative to motor information(BAS-11~16), overload trip(PRT-17~22) and E-thermal functions(PRT-40~43).
- The minimum input voltage must be larger than 228Vac for 240Vac supply and 456Vac for 480Vac supply to ensure motor voltage production of 207Vac and 415Vac, respectively.
- To minimize the effect of voltage deprivation, please choose 208Vac motor for 240Vac supply and 400Vac motor for 480Vac supply.

Product Warranty

Warranty Information

Fill in this warranty information form and keep this page for future reference or when warranty service may be required.

| | | | |
|----------------------|----------------------------------|-----------------------------|--|
| Product Name | LS ELECTRIC Standard Inverter | Date of Installation | |
| Model Name | LSLV-H100 | Warranty Period | |
| Customer Info | Name (or company) | | |
| | Address | | |
| | Contact Info. | | |
| Retailer Info | Name | | |
| | Address | | |
| | Contact info. | | |

Warranty Period

The product warranty covers product malfunctions, under normal operating conditions, for 12 months from the date of installation. If the date of installation is unknown, the product warranty is valid for 18 months from the date of manufacturing. Please note that the product warranty terms may vary depending on purchase or installation contracts.

Warranty Service Information

During the product warranty period, warranty service (free of charge) is provided for product malfunctions caused under normal operating conditions. For warranty service, contact an official LS ELECTRIC agent or service center.

Non-Warranty Service

A service fee will be incurred for malfunctions in the following cases:

- intentional abuse or negligence
- power supply problems or from other appliances being connected to the product
- acts of nature (fire, flood, earthquake, gas accidents, etc.)
- modifications or repair by unauthorized persons
- missing authentic LS ELECTRIC rating plates
- expired warranty period

Visit Our Website

Visit us at <http://www.lselectric.co.kr> for detailed service information.

UL mark



The UL mark applies to products in the United States and Canada. This mark indicates that UL has tested and evaluated the products and determined that the products satisfy the UL standards for product safety. If a product received UL certification, this means that all components inside the product had been certified for UL standards as well. Suitable for Installation in a Compartment Handling Conditioned Air

CE mark



The CE mark indicates that the products carrying this mark comply with European safety and environmental regulations. European standards include the Machinery Directive for machine manufacturers, the Low Voltage Directive for electronics manufacturers and the EMC guidelines for safe noise control.

Low Voltage Directive

We have confirmed that our products comply with the Low Voltage Directive (EN 61800-5-1).

EMC Directive

The Directive defines the requirements for immunity and emissions of electrical equipment used within the European Union. The EMC product standard (EN 61800-3) covers requirements stated for drives.

EAC mark



The EAC (EurAsian Conformity) mark is applied to the products before they are placed on the market of the Eurasian Customs Union member states.

It indicates the compliance of the products with the following technical regulations and requirements of the Eurasian Customs Union:

Technical Regulations of the Customs Union 004/2011 “On safety of low voltage equipment”

Technical Regulations of the Customs Union 020/2011 “On electromagnetic compatibility of technical products”

EC DECLARATION OF CONFORMITY

We, the undersigned,

Representative: **LS ELECTRIC Co., Ltd.**
Address: **LS Tower, 127, LS-ro, Dongan-gu,
Anyang-si, Gyeonggi-do,
Korea⁺**

Manufacturer: **LS ELECTRIC Co., Ltd.⁺**
Address: **56, Samseong 4-gil, Mokcheon-eup,
Dongnam-gu, Cheonan-si, Chungcheongnam-
do,
Korea**

Certify and declare under our sole responsibility that the following apparatus:

Type of Equipment: **Inverter (Power Conversion Equipment)**

Model Name: **LSLV-H100 series⁺**

Trade Mark: **LS ELECTRIC Co., Ltd.**

Conforms with the essential requirements of the directives:

2014/35/EU Directive of the European Parliament and of the Council on the harmonisation of the laws of the Member States relating to the making available on the market of electrical equipment designed for use within certain voltage limits

2014/30/EU Directive of the European Parliament and of the Council on the harmonisation of the laws of the Member States relating to electromagnetic compatibility

Based on the following specifications applied:

**EN 61800-3:2004/A1:2012
EN 61800-5-1:2007**

and therefore complies with the essential requirements and provisions of the 2014/35/CE and 2014/30/CE Directives..

Place: **Cheonan, Chungnam,
Korea**

이성문 2016.1.13

(Signature Date)

**Mr. Sang Chun Moon / General Manager
(Full name / Position)**

EMI / RFI POWER LINE FILTERS

LS inverters, H100 series

VMC
vector motor control

RFI FILTERS

THE LS RANGE OF POWER LINE FILTERS FLDIA AND FEP (Standard) SERIES, HAVE BEEN SPECIFICALLY DESIGNED WITH HIGH FREQUENCY LS INVERTERS. THE USE OF LS FILTERS, WITH THE INSTALLATION ADVICE OVERLEAF HELP TO ENSURE TROUBLE FREE USE ALONG SIDE SENSITIVE DEVICES AND COMPLIANCE TO CONDUCTED EMISSION AND IMMUNITY STANDARDS TO EN 5061.

CAUTION

IN CASE OF A LEAKAGE CURRENT PROTECTIVE DEVICES IS USED ON POWER SUPPLY, IT MAY BE FAULT AT POWER-ON OR OFF. IN AVOID THIS CASE, THE SENSE CURRENT OF PROTECTIVE DEVICE SHOULD BE LARGER

RECOMMENDED INSTALLATION INSTRUCTIONS

To conform to the EMC directive, it is necessary that these instructions be followed as closely as possible. Follow the usual safety procedures when working with electrical equipment. All electrical connections to the filter, inverter and motor must be made by a qualified electrical technician.

- 1-) Check the filter rating label to ensure that the current, voltage rating and part number are correct
- 2-) For best results the filter should be fitted as closely as possible to the incoming mains supply of the wiring enclosure, usually directly after the enclosures circuit breaker or supply switch.
- 3-) The back panel of the wiring cabinet of board should be prepared for the mounting dimensions of the filter. Care should be taken to remove any paint etc... from the mounting holes and face area of the panel to ensure the best possible earthing of the filter.
- 4-) Mount the filter securely.
- 5-) Connect the mains supply to the filter terminals marked **LINE**, connect any earth cables to the earth stud provided. Connect the filter terminals marked **LOAD** to the mains input of the inverter using short lengths of appropriate gauge cable.
- 6-) Connect the motor and fit the ferrite core (output chokes) as close to the inverter as possible. Armoured or screened cable should be used with the 3 phase conductors only threaded twice through the center of the ferrite core. The earth conductor should be securely earthed at both inverter and motor ends. The screen should be connected to the enclosure body via an earthed cable gland.
- 7-) Connect any control cables as instructed in the inverter instructions manual.

IT IS IMPORTANT THAT ALL LEAD LENGTHS ARE KEPT AS SHORT AS POSSIBLE AND THAT INCOMING MAINS AND OUTGOING MOTOR CABLES ARE KEPT WELL SEPARATED.

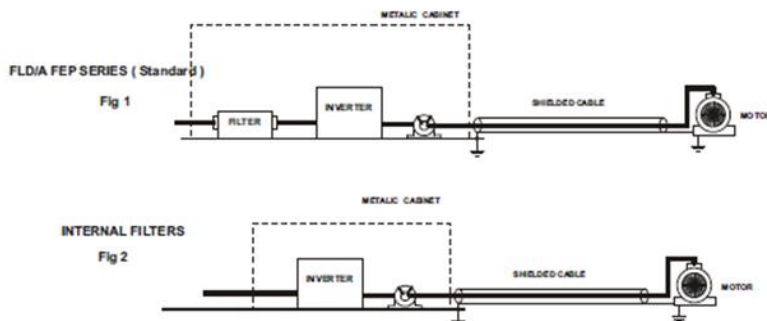

PR0066

| LSLV series / Standard Filters | | | | | | | | | | | | | | |
|--------------------------------|--------|------------|---------|---------|-----------------|------------|------|-----|----------|-----|--------|-------|------|--------------|
| INVERTER | POWER | CODE | CURRENT | VOLTAGE | LEAKAGE CURRENT | DIMENSIONS | | | MOUNTING | | WEIGHT | MOUNT | FIG. | OUTPUT CHOKE |
| | | | | | | NOM. | MAX. | | | | | | | |
| LSLV0008H100-2 | 0.75kW | FLDIA 3007 | 7A | 250VAC | 0.9mA 27mA | 190 | 40 | 70 | 20 | 180 | 1.1Kg | -- | A | FS-1 |
| LSLV0015H100-2 | 1.5kW | FLDIA 3016 | 16A | 250VAC | 0.9mA 27mA | 250 | 45 | 70 | 25 | 235 | 1.7Kg | -- | A | FS-1 |
| LSLV0022H100-2 | 2.2kW | FLDIA 3030 | 30A | 250VAC | 0.9mA 27mA | 270 | 50 | 85 | 30 | 255 | 1.8Kg | -- | A | FS-1 |
| LSLV0037H100-2 | 3.7kW | FLDIA 3030 | 30A | 250VAC | 0.9mA 27mA | 270 | 50 | 85 | 30 | 255 | 1.8Kg | -- | A | FS-2 |
| LSLV0055H100-2 | 5.5kW | FLDIA 3042 | 42A | 250VAC | 0.9mA 27mA | 310 | 50 | 85 | 30 | 295 | 2.4Kg | -- | A | FS-2 |
| LSLV0075H100-2 | 7.5kW | FLDIA 3055 | 55A | 250VAC | 0.9mA 27mA | 250 | 85 | 90 | 60 | 235 | 2.9Kg | -- | A | FS-2 |
| LSLV0110H100-2 | 11kW | FLDIA 3075 | 75A | 250VAC | 0.9mA 27mA | 270 | 80 | 135 | 60 | 255 | 3.6Kg | -- | A | FS-2 |
| LSLV0150H100-2 | 15kW | FLDIA 3100 | 100A | 250VAC | 0.79mA 130mA | 270 | 90 | 135 | 65 | 255 | 5Kg | -- | A | FS-3 |
| LSLV0185H100-2 | 18.5kW | FLDIA 3130 | 130A | 250VAC | 0.79mA 130mA | 270 | 90 | 150 | 65 | 255 | 6.8Kg | -- | A | FS-3 |

EN 55011 CLASS A IEC/EN 61800-3 C3

| LSLV series / Standard Filters | | | | | | | | | | | | | | |
|--------------------------------|-------|-----------|---------|------------|-----------------|-------------|---------|--------|----------|---|--------|-------|------|--------------|
| INVERTER | POWER | CODE | CURRENT | VOLTAGE | LEAKAGE CURRENT | DIMENSIONS | | | MOUNTING | | WEIGHT | MOUNT | FIG. | OUTPUT CHOKE |
| | | | | | | NOM. | MAX. | | | | | | | |
| LSLV1100H100-4 | 110kW | FEP-T320 | 320A | 220-480VAC | 13mA 190mA | 300x260x116 | 240x235 | 14.2Kg | -- | B | FS-4 | | | |
| LSLV1320H100-4 | 132kW | FEP-T320 | 320A | 220-480VAC | 13mA 190mA | 300x260x116 | 240x235 | 14.2Kg | -- | B | FS-4 | | | |
| LSLV1600H100-4 | 160kW | FEP-T400 | 400A | 220-480VAC | 13mA 190mA | 300x260x116 | 240x235 | 14.2Kg | -- | B | FS-4 | | | |
| LSLV1850H100-4 | 185kW | FEP-T600 | 600A | 220-480VAC | 13mA 190mA | 300x260x116 | 240x235 | 16.8Kg | -- | B | FS-4 | | | |
| LSLV2200H100-4 | 220kW | FEP-T600 | 600A | 220-480VAC | 13mA 190mA | 300x260x116 | 240x235 | 16.8Kg | -- | B | FS-4 | | | |
| LSLV2500H100-4 | 250kW | FEP-T600 | 600A | 220-480VAC | 13mA 190mA | 300x260x116 | 240x235 | 16.8Kg | -- | B | FS-4 | | | |
| LSLV3150H100-4 | 315kW | FEP-T1000 | 1000A | 220-480VAC | 13mA 190mA | 350x280x166 | 290x255 | 22.5Kg | -- | B | FS-4 | | | |
| LSLV3550H100-4 | 355kW | FEP-T1000 | 1000A | 220-480VAC | 13mA 190mA | 350x280x166 | 290x255 | 22.5Kg | -- | B | FS-4 | | | |
| LSLV4000H100-4 | 400kW | FEP-T1000 | 1000A | 220-480VAC | 13mA 190mA | 350x280x166 | 290x255 | 22.5Kg | -- | B | FS-4 | | | |
| LSLV5000H100-4 | 500kW | FEP-T1600 | 1600A | 220-480VAC | 13mA 190mA | 400x300x166 | 340x275 | 27.4Kg | -- | B | FS-4 | | | |

EN 55011 CLASS A IEC/EN 61800-3 C3

| LSLV series / Internal Filters | | | |
|--------------------------------|--------|------|--------------|
| INVERTER | POWER | FIG. | OUTPUT CHOKE |
| THREE PHASE | | | |
| LSLV0008H100-4 | 0.75kW | 2 | FS-1 |
| LSLV0015H100-4 | 1.5kW | 2 | FS-1 |
| LSLV0022H100-4 | 2.2kW | 2 | FS-1 |
| LSLV0037H100-4 | 3.7kW | 2 | FS-2 |
| LSLV0055H100-4 | 5.5kW | 2 | FS-2 |
| LSLV0075H100-4 | 7.5kW | 2 | FS-2 |
| LSLV0110H100-4 | 11kW | 2 | FS-2 |
| LSLV0150H100-4 | 15kW | 2 | FS-3 |
| LSLV0185H100-4 | 18.5kW | 2 | FS-3 |
| LSLV0220H100-4 | 22kW | 2 | FS-3 |
| LSLV0300H100-4 | 30kW | 2 | FS-3 |
| LSLV0370H100-4 | 37kW | 2 | FS-3 |
| LSLV0450H100-4 | 45kW | 2 | FS-4 |
| LSLV0550H100-4 | 55kW | 2 | FS-4 |
| LSLV0750H100-4 | 75kW | 2 | FS-4 |
| LSLV0900H100-4 | 90kW | 2 | FS-4 |

EN 55011 CLASS A IEC/EN 61800-3 C3

FIG. 2

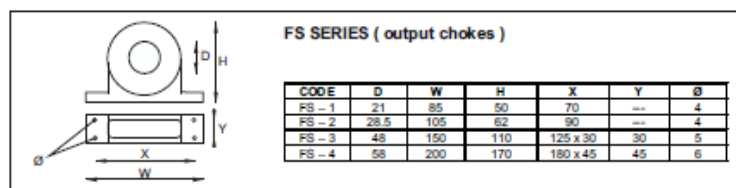

Index

I

| | |
|--------------------------------|----|
| [AUTO] key | 53 |
| [DOWN] key..... | 53 |
| [ESC] key | 53 |
| [HAND] key..... | 53 |
| [LEFT] key..... | 53 |
| [Mode] key..... | 53 |
| [MULTI] key..... | 53 |
| [MULTI] key configuration..... | 55 |
| [OFF] key..... | 53 |
| [PROG / Ent] key..... | 53 |
| [RIGHT] key..... | 53 |
| [UP] key..... | 53 |

2

| | |
|---------------------------------------|--------|
| 24 terminal..... | 40, 41 |
| 2 nd motor operation | 243 |
| 2 nd operation mode..... | 137 |
| 2 nd command source | 137 |
| Shared command (Main Source)..... | 137 |
| Shared command (Main Source)..... | 137 |

3

| | |
|-----------------------|-----|
| 3-wire operation..... | 152 |
|-----------------------|-----|

4

| | |
|----------------------------|---------------------------------|
| 4-pole standard motor..... | 560, 561, 562, 563, 564, 565 |
|----------------------------|---------------------------------|

A

| | |
|---|---------------------------------------|
| A terminal (Normally Open)..... | 139 |
| A1/C1/B1 terminal..... | 40 |
| AC power input terminal | Refer to R/S/T terminal |
| Acc/Dec pattern | 79, 117 |
| linear pattern | 117 |
| S-curve pattern | 117 |
| Acc/Dec reference | 113 |
| Delta Freq..... | 112 |
| Max Freq | 112 |
| Acc/Dec reference frequency | 112 |
| Ramp T Mode..... | 112 |
| Acc/Dec stop..... | 79, 120 |
| Acc/Dec time..... | 111 |
| Acc/Dec time switch frequency..... | 116 |
| configuration via multi-function terminal | 113 |
| maximum frequency | 111 |
| operation frequency | 113 |
| Acc/Dec time configuration..... | 79 |
| accelerating start..... | 80 |
| add User group | |
| UserGrp SelKey | 251 |
| ADV (advanced) | 60 |
| ADV (Expanded function group)..... | 408 |
| advanced features group..... | 60 |
| Advanced function group..... | Refer to ADV (advanced) |
| function group | |
| analog frequency hold..... | 100 |
| analog hold..... | 100 |
| analog hold..... | Refer to <i>analog frequency hold</i> |
| analog input..... | 38, 60 |
| I2 current input | 94 |
| I2 voltage input..... | 96 |
| T1 pulse input..... | 97 |
| V1 voltage input..... | 88 |

| | |
|---|-------------------------------|
| analog input selection switch (SW2)..... | 96 |
| analog input selection switch (SW4)..... | 36 |
| analog output..... | 39, 293 |
| AO terminal..... | 39 |
| pulse output..... | 296 |
| voltage and current output..... | 293 |
| analog output selection switch (SW5)..... | 36, 293 |
| anti-hunting regulation..... | 231 |
| AO terminal..... | 39, 293 |
| analog output selection switch (SW5)..... | 36 |
| AP1 (Application 1 function group)..... | 459 |
| AP1 (Application1 function group)..... | 60 |
| AP2 (Application 2 function group)..... | 60, 467 |
| AP3 (Application 3 function group)..... | 60, 472 |
| ARM short current fault trip..... | Refer to <i>Over Current2</i> |
| ASCII code..... | 356 |
| asymmetric ground power..... | 43 |
| asymmetric ground structure | |
| disabling the EMC filter..... | 43 |
| asynchronous communications system..... | 342 |
| auto restart..... | 239 |
| auto restart settings..... | 239 |
| auto torque boost..... | 126 |
| auto torque boost 1..... | 126 |
| auto torque boost 2..... | 126 |
| auto tuning..... | 211 |
| auto tuning..... | 211, 405 |
| All (rotating)..... | 213 |
| All (static)..... | 214 |
| default parameter setting..... | 212 |
| automatic reset after a trip..... | 79 |
| automatic start-up at power-on..... | 79 |
| automatic torque boost..... | 80 |
| auto-tuning..... | 211 |
| auxiliary command source..... | 81 |
| auxiliary frequency..... | 143 |
| auxiliary frequency reference configuration.... | 144 |
| auxiliary reference..... | 143 |
| auxiliary reference gain..... | 144 |
| final command frequency calculation..... | 145 |

| | |
|---------------------------------------|----------|
| main reference..... | 143 |
| auxiliary motor PID compensation..... | 283, 284 |

B

| | |
|--|-------------------------------------|
| B terminal (Normally Closed)..... | 139 |
| BACnet..... | 344, 381 |
| analog input object..... | 387 |
| analog value object..... | 386 |
| binary input object..... | 390 |
| binary object..... | 387 |
| communication standard..... | 381 |
| data link layer..... | 384 |
| defining..... | 381 |
| error message..... | 391 |
| MAC ID/Sevice object Instance..... | 384 |
| Max Master Property..... | 384 |
| multi-state input object..... | 391 |
| multi-state object..... | 387 |
| object map..... | 384 |
| parameter setup..... | 381 |
| protocol..... | 381 |
| protocol implement..... | 384 |
| quick start..... | 381 |
| BACnet object | |
| analog..... | 386 |
| analog input..... | 387 |
| binary..... | 387 |
| binary input..... | 390 |
| error message..... | 391 |
| multi-state..... | 387 |
| multi-state input..... | 391 |
| BAS (Basic function group)..... | 402 |
| BAS (Basic group)..... | 60 |
| basic configuration diagram | 18 |
| Basic group..... | Refer to BAS (Basic function group) |
| basic operation..... | 52 |
| battery replacement..... | 555 |
| bipolar..... | 39, 92 |
| bit 139 | |
| bit (Off)..... | 139 |
| bit (On)..... | 139 |
| bit setting..... | 139 |
| multi-function input setting..... | 139, 140 |

| | |
|--|--------------------------------------|
| multi-function output setting | 303 |
| Reset Restart configuration | 240 |
| speed search configuration | 236 |
| stall prevention | 317 |
| brake unit | 292 |
| braking resistor | 31 |
| braking resistors | 18 |
| broadcast | 353 |
| built-in communication | Refer to <i>RS-485</i> BX340, 538 |

C

| | |
|--|----------------------|
| cable | 14, 27, 28, 29, 36 |
| ground cable specifications | 14 |
| power cable specifications | 14 |
| selection | 14, 27, 28, 29, 36 |
| shielded twisted pair | 49 |
| cable tie | 40 |
| CAP. Warning | 540 |
| carrier frequency | 241 |
| derating | 592 |
| factory default | 242 |
| charge indicator | 26, 536, 544 |
| charge lamp | 26 |
| Circulation Pump (MC5) | 519 |
| cleaning | 551 |
| CleanRPTerr | 539 |
| CM terminal | 38, 41 |
| COM (Communication function group) | 60 |
| command | 103 |
| Cmd Source | 103 |
| configuration | 103 |
| command source | |
| fwd/rev command terminal | 104 |
| keypad | 103 |
| RS-485 | 106 |
| commercial power source transition | 244 |
| common terminal | Refer to EG terminal |
| communication | 342 |
| BACnet | 381 |

| | |
|--|--|
| command loss protective operation | 346 |
| communication address | 358 |
| communication line connection | 343 |
| communication parameters | 344 |
| communication speed | 344 |
| communication standards | 342 |
| memory map | 349 |
| parameter group for data transmission | 349 |
| PLC | 342 |
| saving parameters defined by communication | 348 |
| setting virtual multi-function input | 348 |
| Communication function group | Refer to COM (communication function group) |
| communication system configuration | 343 |
| compatible common area parameter | 361 |
| CON (Control function group) | 60, 415 |
| Config (CNF) mode | 254 |
| inverter S/W version | 254 |
| keypad S/W version | 254 |
| keypad title update | 254 |
| LCD contrast | 254 |
| reset cumulative power consumption | 254 |
| Config mode | 493 |
| Config mode (CNF) | 494 |
| configuration mode | 59 |
| considerations for installation | |
| air pressure | 10 |
| considerations for installation | 10 |
| altitude/vibration | 10 |
| ambient humidity | 10 |
| ambient temperature | 10 |
| environmental factors | 10 |
| storing temperature | 10 |
| Control group | Refer to CON (control function group) |
| control terminal board wiring | 36 |
| cooling fan | |
| cumulated fan operation time | 307 |
| fan control | 245 |
| fan malfunctions | 329 |
| initialize cumulated fan operation time | 307 |
| Cooling Tower (MC4) | 516 |

| | |
|-------------------|----|
| cursor keys | 53 |
| [DOWN] key | 53 |
| [LEFT] key | 53 |
| [RIGHT] key..... | 53 |
| [UP] key | 53 |

D

| | |
|---------------------------------|---------------------------------|
| damper..... | 188 |
| Damper Err Trip..... | Refer to <i>Damper Err Trip</i> |
| damper operation..... | 188 |
| damper open delay time | 188 |
| DB resistor | |
| braking resistor circuit..... | 326 |
| DB Warn %ED | 326 |
| DB Warn %ED..... | 326, 540 |
| DC braking after start..... | 128 |
| DC braking after stop..... | 130 |
| DC braking frequency | 130 |
| DC link voltage | 141 |
| Dec valve ramping..... | 200 |
| deceleration stop | 80 |
| delta wiring..... | 43 |
| derating | 242, 592 |
| digital output..... | 298 |
| display..... | 54 |
| command source | 54 |
| display mode table..... | 59 |
| display modes | 58 |
| frequency reference..... | 54 |
| operation mode | 54 |
| rotational direction..... | 54 |
| disposal..... | 551, 559 |
| draw operation | 141 |
| Drive group..... | Refer to DRV (Drive group) |
| DRV (Drive function group)..... | 60 |
| DRV (Drive group)..... | 397 |
| dwell operation..... | 155 |
| Acc/Dec dwell frequency | 155 |
| acceleration dwell | 155 |
| deceleration dwell | 155 |

| | |
|--|-----|
| dynamic braking (DB) resistor configuration..... | 326 |
|--|-----|

E

| | |
|---|---|
| earth leakage breaker..... | 547 |
| Easy Start On..... | 252 |
| EEP Rom Empty..... | 247 |
| EG terminal | 40 |
| electronic thermal overheating protection (ETH) | |
| | 310 |
| EMC filter | 43 |
| asymmetric power source | 43 |
| disabling | 43, 44, 45, 46 |
| enable | 44 |
| enabling | 44, 45, 46 |
| emergency stop fault trip..... | Refer to <i>BX</i> |
| Enclosed Type 1 | 568 |
| energy saving..... | 192 |
| energy saving operation | 234 |
| automatic energy saving operation..... | 234 |
| manual energy saving operation..... | 234 |
| EPID (EPID control) group..... | 60 |
| EPID (External PID function group)..... | 452 |
| EPID control | |
| external PID | 178 |
| EPID control group..... | 60 |
| ETH..... | Refer to <i>electronic thermal overheating protection (ETH)</i> |
| E-Thermal..... | 537 |
| Exception Date..... | 215 |
| Exhaust Fan (MC3)..... | 504 |
| external 24V power terminal.... | Refer to 24 terminal |
| External Trip..... | 538 |
| external trip signal..... | 321 |

F

| | |
|--------------------------|-----|
| falut trips..... | 536 |
| fan life estimation..... | 337 |

| | | | |
|--|-------------------|--|---------|
| fan replacement level | 337 | Over Load Trip | 339 |
| fan time | 337 | Over Voltage | 339 |
| fan operation warning | 340 | ParaWrite Trip | 339 |
| fan replacement warning..... | 541 | Pipe Broken Trip | 339 |
| Fan Trip..... | 329, 538 | Pipe Broken Warning | 340 |
| Fan Warning..... | 329, 540 | Under Load Trip..... | 339 |
| fatal | 536 | FE (Frame Error)..... | 356 |
| fault..... | 339 | ferrite..... | 40 |
| fatal..... | 536 | fieldbus..... | 86, 103 |
| latch..... | 536 | communication option..... | 137 |
| level | 536 | FIFO/FILO..... | 263 |
| major fault..... | 339 | filter time constant..... | 88 |
| fault monitoring..... | 75 | filter time constant number..... | 138 |
| multiple fault trips | 76 | Fire mode..... | 232 |
| fault signal output terminal | Refer to A1/C1/B1 | Fire Mode Warning..... | 540 |
| terminal | | flow compensation | 191 |
| fault trip mode..... | 59 | maximum compensation value | 191 |
| fault/warning list..... | 339 | flux braking..... | 316 |
| braking resistor braking rate warning..... | 340 | forward or reverse run prevention..... | 107 |
| capacitor lifetime warning..... | 340 | free-run stop..... | 81, 131 |
| CleanRPTErr Trip | 339 | frequency hold by analog input | 100 |
| CPU Watch Dog fault trip | 340 | frequency jump | 81, 136 |
| Damper Err Trip..... | 339 | frequency limit | 81, 133 |
| E-Thermal..... | 339 | frequency jump | 136 |
| External Trip | 339 | frequency upper and lower limit value..... | 134 |
| fan replacement warning..... | 340 | maximum/start frequency | 133 |
| Fan Trip | 339 | frequency reference | 87, 128 |
| Fan Warning..... | 340 | frequency reference for 0–10V input..... | 88 |
| Fire mode Warning | 340 | frequency reference for -10–10V Input..... | 92 |
| Ground Trip..... | 339 | frequency reference source configuration | 78 |
| In Phase Open | 339 | frequency setting | 86 |
| IO Board Trip | 339 | I2 current input | 94 |
| Level Detect trip | 339 | I2 voltage input..... | 96 |
| Level Detect Warning | 340 | keypad | 87 |
| Lost Command | 340 | RS-485 | 99 |
| Low Battery Warning | 340 | T1 pulse input..... | 97 |
| Low Voltage..... | 340 | V1 voltage input..... | 88 |
| Low Voltage2..... | 339 | frequency setting (Pulse train) terminal..Refer to <i>V1</i> | |
| No Motor Trip..... | 339 | <i>terminal</i> | |
| NTC Open | 339 | frequency setting(voltage) terminal.....Refer to <i>V1</i> | |
| Option Trip-x..... | 339 | <i>terminal</i> | |
| Out Phase Open | 339 | | |
| Over Current1 | 339 | | |
| Over Current2 | 339 | | |
| Over Heat | 339 | | |

| | |
|---------------------------------------|-----|
| frequency upper and lower limit value | |
| Frequency lower limit value | 134 |
| Frequency upper limit value..... | 134 |
| fuse specifications..... | 578 |

G

| | |
|----------------------------------|-----------------------------|
| ground..... | 28 |
| class 3 ground..... | 29 |
| ground cable specifications..... | 14 |
| ground fault trip..... | Refer to <i>Ground Trip</i> |
| Ground Trip..... | 537 |

H

| | |
|--|-----|
| H100 expansion common area parameter..... | 365 |
| control area parameter (Read/Write) | 376 |
| memory control area parameter (Read/Write) | |
| | 379 |
| monitor area parameter (read only) | 366 |
| half duplex system..... | 342 |

I

| | |
|--|-------------------------------|
| I/O point map..... | 393 |
| I2 39 | |
| analog input selection switch (SW4)..... | 39 |
| frequency setting(current/voltage) terminal | 39 |
| I2 Terminal | 94 |
| IA (illegal data address)..... | 356 |
| ID (illegal data value) | 356 |
| IF (illegal function)..... | 356 |
| IN (Input terminal function group) | 60, 418 |
| In Phase Open..... | 537 |
| initializing accumulated electric energy count...254 | |
| input and output specifications..560, 596, 597, 598 | |
| input open-phase fault trip..... | Refer to <i>In Phase Open</i> |
| input phase open | |
| input open-phase protection | 320 |
| input power frequency..... | 246 |

| | |
|--|---|
| input power voltage | 246 |
| input power voltage settings..... | 246 |
| input terminal | 38, 139 |
| A (NO) or B (NC) terminal configuration..... | 139 |
| bit setting | 139 |
| CM terminal..... | 38 |
| I2 terminal..... | 39 |
| NO/NC configuration | 139 |
| P1–P7 terminal | 38 |
| T1 terminal | 39 |
| V1 terminal | 38 |
| VR terminal | 38 |
| input terminal contact | |
| A contact..... | 321 |
| B contact..... | 321 |
| Input terminal function group..... | Refer to IN (Input terminal function group) |
| inspection | |
| annual inspection..... | 552 |
| bi-annual inspection | 554 |
| daily inspection | 551 |
| installation..... | 17 |
| basic configuration diagram | 18 |
| installation flowchart | 17 |
| location | 11 |
| mounting the Inverter | 19 |
| side-by-side installation..... | 12 |
| wiring..... | 26 |
| installation conditions..... | 10 |
| INV Over Load | |
| Inv Over Load Warning | 540 |
| Inverter OLT..... | 537 |
| inverter overload protection (IOLT)..... | 322 |
| Inverter overload warning..... | 340 |
| IO Board connection fault trip..... | Refer to <i>IO Board Trip</i> |
| IO Board Trip | 539 |
| IP 20 | 568 |
| IP 20 Type external dimensions..... | 570 |

| | |
|--|-----|
| J | |
| Jog operation..... | 148 |
| FWD Jog..... | 148 |
| Jog frequency..... | 148 |
| Jog operation 2 by terminal input | 149 |
| Jog operation 2-Rev Jog by terminal input..... | 149 |
| jump frequency..... | 136 |

| | |
|--------------------------------|--------|
| K | |
| keypad..... | 52 |
| [AUTO] key..... | 53 |
| [ESC] key..... | 53 |
| [HAND] key..... | 53 |
| [Mode] key..... | 53 |
| [MULTI] key | 53, 56 |
| [OFF] key..... | 53 |
| [PROG / Ent] key | 53 |
| code information | 57 |
| Config mode (CNF) | 494 |
| configuration mode | 59 |
| cursor keys..... | 53 |
| display | 52, 54 |
| display item..... | 57 |
| display mode | 58 |
| LCD brightness/contrast..... | 254 |
| monitor mode | 59 |
| monitor mode cursor..... | 55 |
| monitor mode item | 55 |
| navigating between groups..... | 58 |
| operating status..... | 55, 57 |
| operation keys | 52 |
| operation mode | 56 |
| parameter group | 56 |
| parameter mode | 59 |
| parameter value | 57 |
| rotational direction..... | 56 |
| SW version | 254 |
| set value..... | 57 |
| setting range..... | 57 |
| status bar configuration | 55 |
| trip mode | 59 |
| User & Macro mode | 59 |
| wiring length | 40 |
| keypad display..... | 54 |

| | |
|--|-----|
| keypad features | |
| fault monitoring | 75 |
| navigating directly to different codes..... | 68 |
| navigating through the codes | 66 |
| operation modes..... | 62 |
| parameter settings..... | 70 |
| selecting a display mode | 61 |
| selecting the status bar display item..... | 73 |
| setting the monitor display items..... | 72 |
| switching between groups in Parameter Display mode..... | 64 |
| switching between groups in User & Macro mode..... | 65 |
| keypad title update | 254 |
| keypad trip mode..... | 493 |
| kinetic energy buffering..... | 229 |

| | |
|---------------------------------------|----------|
| L | |
| latch..... | 536 |
| LCD display..... | 54 |
| leakage breaker..... | 575 |
| learning basic features..... | 78 |
| level..... | 536 |
| level detectiontrip restart time..... | 203 |
| Level Detect..... | 539 |
| Level Detect Warning..... | 540 |
| Level Detect Trip..... | 339 |
| level detection control | 203 |
| lift-type load..... | 117, 125 |
| linear pattern | 117 |
| linear V/F operation..... | 80 |
| linear V/F pattern operation..... | 121 |
| base frequency | 121 |
| start frequency | 121 |
| load tuning..... | 201 |
| Lost Command..... | 539 |
| command loss fault trip warning | 340 |
| command loss trip | 340 |
| Lost Command Warning..... | 540 |
| Lost KeyPad..... | 538 |
| Lost KeyPad Warning | 540 |

| | |
|---|----------|
| Low Battery | |
| low battery warning..... | 541 |
| low battery warning..... | 327 |
| low voltage..... | 330 |
| low voltage fault trip | 330, 340 |
| Low Voltage..... | 537 |
| Low voltage fault trip during operation | Refer to |
| <i>Low Voltage2 Trip</i> | |
| Low Voltage2..... | 537 |
| LowLeakage PWM | 241 |
| LS INV 485 communication..... | 348 |
| LS INV 485 Detailed Read Protocol..... | 353 |
| LS INV 485 Detailed Write Protocol..... | 354 |
| LS INV 485 error code | 356 |
| FE (Frame Error)..... | 356 |
| IA (illegal data address) | 356 |
| ID (illegal data value)..... | 356 |
| IF (illegal function) | 356 |
| WM (write mode error) | 356 |
| LS INV 485 protocol | 352 |
| LSINV 485 | 344 |
| lubrication..... | 190 |
| lubrication operation..... | 190 |

M

| | |
|--|-----|
| M2 (Secondary Motor function group)..... | 489 |
| M2 (secondary motor-related features) group..... | 60 |
| Macro | |
| Circulation Pump (MC5)..... | 519 |
| Constant Torque (MC7)..... | 532 |
| Cooling Tower (MC4)..... | 516 |
| Exhaust Fan (MC3) | 504 |
| Supply Fan (MC2) | 503 |
| Vacuum Pump (MC6)..... | 523 |
| Macro function group..... | 499 |
| Macro group..... | 499 |
| Macro mode..... | 61 |
| macro selection | 255 |
| Macro selection | |

| | |
|---|--------------------|
| Basic | 255 |
| Circulation Pump | 255 |
| Compressor | 255 |
| Constant Torque | 255 |
| Coolong Tower..... | 255 |
| Supply Fan..... | 255 |
| Vacuum Pump | 255 |
| magnetic contactor | 575 |
| main capacitor life estimation..... | 335 |
| CAP Level 1 | 336 |
| CAP Level 2 | 336 |
| maintenance | 551 |
| manual torque boost..... | 80, 125 |
| master | 343 |
| maximum allowed prospective short-circuit | |
| current | iii |
| megger test..... | 552, 555 |
| Metasys-N2 | 344 |
| analog input..... | 394 |
| analog output | 393 |
| binary input..... | 395 |
| binary output | 394 |
| communication standard | 392 |
| error code | 396 |
| I/O point map | 393 |
| protocol..... | 392 |
| metasys-N2 communication..... | 392 |
| Metasys-N2 I/O map | |
| analog input..... | 394 |
| analog output | 393 |
| binary input..... | 395 |
| binary output | 394 |
| MMC..... | 257 |
| auto cahnge | 269, 270, 281, 282 |
| auto change aux | 275 |
| basic sequence..... | 264 |
| interlock | 277 |
| Regular Bypass | 286, 287, 288, 289 |
| MMC Interlock | 539 |
| Modbus-RTU..... | 344 |
| Modbus-RTU communication | 348 |
| Modbus-RTU function code and protocol | 358 |
| Modbus-RTU protocol | |

| | |
|--|----------|
| exception code | 361 |
| read holding register | 358 |
| read input register | 358 |
| momentary power interruption..... | 237, 238 |
| monitoring | |
| monitor mode | 59 |
| monitor mode cursor..... | 55 |
| monitor mode display | 54 |
| monitor mode item | 55 |
| monitor registration protocol details | 355 |
| operation state monitoring..... | 305 |
| operation time monitoring..... | 307 |
| motor features | |
| capacity | 157 |
| efficiency | 157 |
| no-load current | 157 |
| operation display options | 78 |
| output voltage adjustment..... | 127 |
| overheat sensor | 312 |
| protection | 310 |
| rotation control..... | 79 |
| thermal protection(ETH) | |
| E-Thermal..... | 310 |
| verifying rotational direction..... | 51 |
| Motor overheat fault trip..... | 339 |
| motor thermal protection(ETH) | |
| ETH trip | 310 |
| mounting bolt | 19 |
| Multi Key | |
| Multi key item..... | 496 |
| Multi Key Sel..... | 496 |
| multi-drop link system..... | 342 |
| multi-function input terminal | 38 |
| factory default..... | 38 |
| IN 65–71 | 421 |
| multi-function input terminal Off filter | 138 |
| multi-function input terminal On filter | 138 |
| P1–P7 | 38 |
| Px Define | 421 |
| Px terminal configuration..... | 421 |
| multi-function input terminal control | 138, 140 |
| multi-function input terminals | |
| factory default..... | 38 |
| multi-function output terminal | |

| | |
|---|-----|
| multi-function output category (Q1 Define) | 430 |
| multi-function output on/off control | 290 |
| multi-function output terminal and relay settings | 298 |
| multi-function output terminal delay time settings | 304 |
| multi-function relay1 category (Relay 1)..... | 429 |
| multi-function relay2 category (Relay 2)..... | 430 |
| multi-function relay3category (Relay 3)..... | 430 |
| multi-function relay4 category (Relay 4)..... | 430 |
| multi-function relay5 category (Relay 5)..... | 430 |
| trip output by multi-function output terminal and relay | 303 |
| multi-function terminal configuration..... | 81 |
| multiple motor control | 257 |
| multi-step frequency | 101 |
| setting | 101 |
| Speed-L/Speed-M/Speed-H | 102 |
| multi-step speed (frequency)..... | 78 |

N

| | |
|-----------------------------|--------|
| no motor trip | 332 |
| No Motor Trip..... | 537 |
| noise..... | 43, 90 |
| Normal PWM..... | 241 |
| NPN mode (Sink)..... | 42 |
| NTC Open..... | 538 |
| number of motor poles | 157 |

O

| | |
|--|-----------------------------------|
| open-phase protection..... | 320 |
| operation frequency | Refer to <i>frequency setting</i> |
| operation mode selection..... | 78 |
| operation noise | 241 |
| carrier frequency..... | 241 |
| frequency jump | 136 |
| operation time | 307 |
| cumulated operation time | 307 |
| initialize cumulated operation time..... | 307 |
| inverter power-on time | 307 |

| | |
|--|---|
| option trip..... | 332, Refer to <i>Option Trip-x</i> |
| Option Trip-1..... | 539 |
| Option Trip-x | |
| option trip..... | 339 |
| OUT (Output terminal function group)..... | 60, 427 |
| Out Phase Open..... | 537 |
| output block by multi-function terminal..... | 331 |
| output open-phase fault trip..... | Refer to <i>Out Phase Open</i> |
| output terminal..... | Refer to R/S/T terminal |
| Output terminal function group..... | Refer to OUT (Output terminal function group) |
| output/communication terminal..... | 39 |
| 24 terminal | 40 |
| A1/C1/B1 terminal | 40 |
| AO terminal | 39 |
| EG terminal | 40 |
| S+/S-/SG terminal | 40 |
| over current trip..... | Refer to <i>Over Current1</i> |
| Over Current1..... | 537 |
| Over Current2..... | 537 |
| Over Heat..... | 537 |
| over heat fault trip..... | Refer to <i>Over Heat</i> |
| Over Load..... | 536 |
| Over Load Warning..... | 540 |
| overload fault trip..... | 339 |
| overload warning..... | 340 |
| Over Voltage..... | 537 |
| over voltage trip..... | Refer to <i>Over Voltage</i> |
| overload..... | Refer to <i>Over Load</i> |
| overload trip..... | 314 |
| overload warning..... | 314 |
| overload rate..... | 242 |
| overload trip..... | Refer to <i>Over Load</i> |

P

| | |
|---|--------|
| P(+) terminal (+ DC link terminal)..... | 33, 34 |
| P/I gain..... | 238 |
| P1+ terminal (+ DC link terminal)..... | 31 |

| | |
|---|-----------------------------------|
| P2+ terminal (+ DC link terminal)..... | 31, 32 |
| P2+/B terminal..... | 31 |
| P3+ terminals (+ DC link terminal)..... | 32 |
| parameter..... | 70 |
| display changed parameter..... | 250 |
| hide parameter mode..... | 249 |
| initializing the parameters..... | 77 |
| parameter initialization | 248 |
| parameter lock..... | 249 |
| parameter settings..... | 70 |
| password..... | 249 |
| Parameter Initialization..... | 248 |
| parameter mode..... | 59 |
| parameter setting mode..... | 60 |
| ParaWrite Trip..... | 539 |
| parameter | |
| read/write/save..... | 247 |
| part names..... | 3 |
| parts illustrated..... | 3 |
| parts life..... | 335 |
| capacitor life estimation..... | 335 |
| fan life..... | 337 |
| password..... | 249, 380 |
| payback counter..... | 192 |
| peripheral devices..... | 575 |
| phase-to-phase voltage..... | 546 |
| PID | |
| flow control..... | 158 |
| pressure control..... | 158 |
| speed control..... | 158 |
| temperature control..... | 158 |
| PID (Advanced function group)..... | 440 |
| PID (PID control) group..... | 60 |
| PID control | |
| PID openloop..... | 177 |
| PID operation sleep mode..... | 175 |
| PID operation switching..... | 177 |
| PID reference..... | 169 |
| PID control group..... | Refer to PID (PID control) group) |
| pipe break..... | 207 |

| | |
|--|---|
| pipe break detection control | |
| Pipe Broken | 207 |
| pipe break detection control | |
| Pipe Broken | 539 |
| Pipe Broken Warning | 540 |
| Pipe Broken fault trip | Refer to <i>PipeBroken Trip</i> |
| PNP mode (Source) | 41 |
| PNP/NPN mode selection switch (SW2) | 36 |
| NPN mode (Sink) | 42 |
| PNP mode (Source) | 41 |
| post-installation checklist | 48 |
| potentiometer | 38 |
| power braking | 81 |
| power consumption | 306, 307 |
| power input terminal | Refer to <i>R/S/T terminal</i> , Refer to <i>R/S/T terminal</i> |
| power output terminal | Refer to <i>R/S/T terminal</i> , Refer to <i>R/S/T terminal</i> |
| power terminal board wiring | 29 |
| power terminals | 32, 33 |
| P(+) terminal | 33, 34 |
| P(+)/B terminal | 33 |
| P1+ terminal | 31 |
| P2+ terminal | 31, 32 |
| P2+/B terminal | 31 |
| P3+ terminal | 32 |
| R/S/T terminals | 31, 32, 33, 34 |
| U/V/W terminal | 31, 32, 33, 34 |
| PowerOn Resume | 308 |
| PowerOn Resume by serial communication | 308 |
| Power-on Run | 108 |
| pre-heating | 209 |
| preparing the installation | 1 |
| press regeneration prevention | 291 |
| P gain/l gain | 292 |
| product identification | 1 |
| product specification details | 566 |
| protocol | |
| BACnet protocol | 381 |
| LS INV 485 protocol | 352 |
| Metasys-N2 protocol | 392 |

| | |
|---------------------------------------|---------------------------------|
| PRT (protection features) group | 60 |
| PRT (Protection function group) | 479 |
| Pulse output terminal | Refer to TO terminal |
| pump clean | 194 |
| Pump clean trip | Refer to <i>Pump Clean Trip</i> |
| PWM | 241 |
| frequency modulation | 241 |

Q

| | |
|-----------------------|----|
| quantizing | 90 |
| Quantizing | |
| noise | 90 |
| quick reference | iv |

R

| | |
|-------------------------------|---------------------|
| R/S/T terminals | 31, 32, 33, 34, 544 |
| R/S/T terminals | 35 |
| rating | |
| derating | 592 |
| rated motor current | 157 |
| rated motor voltage | 211 |
| rated slip frequency | 157 |
| rated slip speed | 157 |
| rating plate | 1 |
| reactor | 18, 19 |
| reactors specifications | 578 |
| real-time clock | 23 |
| regenerated energy | 132 |
| Reset Restart | 110 |
| settings | 240 |
| resonance frequency | |
| carrier frequency | 241 |
| restarting after a trip | |
| Reset Restart | 110 |
| retry number | 110 |
| ripple | 91 |
| RS-232 | 343 |
| communication | 343 |

| | |
|--|---------|
| RS-485..... | 342 |
| communication..... | 343 |
| converter..... | 343 |
| integrated communication..... | 99 |
| setting command and frequency..... | 346 |
| signal terminal..... | 40, 99 |
| RS-485 signal input terminal..... Refer to S+/S-/SG terminal | |
| RTC battery..... | 23, 555 |
| enabling..... | 23 |
| replacing..... | 555 |
| specifications..... | 555 |
| run prevention | |
| Fwd..... | 107 |
| Rev..... | 107 |

S

| | |
|--|--------|
| S/W version..... | 254 |
| inverter..... | 254 |
| keypad..... | 254 |
| S+/S-/SG terminal..... | 40 |
| safe operation mode..... | 153 |
| safety information..... | ii |
| screw specification | |
| control circuit terminal screw..... | 581 |
| input/output terminal screw..... | 581 |
| screw size..... | 581 |
| screw torque..... | 581 |
| S-curve pattern..... | 117 |
| actual Acc/Dec time..... | 119 |
| secondary motor-related features group..... Refer to M2 (the secondary motor-related features) group | |
| selecting operation modes..... | 62, 81 |
| auto mode operation..... | 82 |
| basic operation..... | 83 |
| function codes..... | 84 |
| hand mode operation..... | 81 |
| mode keys and indicators..... | 82 |
| Power-on Run/PowerOn Resume in each mode..... | 85 |
| switching between the modes..... | 84 |

| | |
|---|--------|
| sequence common terminal..Refer to <i>CM terminal</i> | |
| side-by-side installation..... | 12 |
| slave..... | 343 |
| slip..... | 157 |
| slip compensation operation..... | 157 |
| soft fill control | |
| soft fill operation..... | 173 |
| speed command loss..... | 323 |
| speed search operation..... | 235 |
| Flying Start-1..... | 236 |
| Flying Start-2..... | 236 |
| options..... | 236 |
| P/I gain..... | 238 |
| speed unit selection (Hz or Rpm)..... | 101 |
| square reduction..... | 80 |
| square reduction load..... | 122 |
| V/F pattern operation..... | 122 |
| stall..... | 316 |
| bit On/Off..... | 317 |
| stall prevention..... | 316 |
| start after DC braking..... | 80 |
| start at power-on | |
| PowerOn Resume..... | 109 |
| Power-on Run..... | 108 |
| start mode..... | 128 |
| acceleration start..... | 128 |
| start after DC braking..... | 128 |
| Start&End Ramp operation..... | 198 |
| Station ID..... | 358 |
| stop mode..... | 129 |
| DC braking after stop..... | 130 |
| deceleration stop..... | 129 |
| free run stop..... | 131 |
| power braking..... | 132 |
| storage..... | 559 |
| Supply Fan (MC2)..... | 503 |
| surge killer..... | 35, 49 |
| SW1..... Refer to Terminating Resistor selection switch (SW1) | |
| SW2..... Refer to PNP/NPN mode selection switch (SW2) | |

| | |
|--|----|
| SW3 ... Refer to V1/T1 (PTC) mode selection switch (SW3) | |
| SW4 .. Refer to analog input selection switch (SW4) | |
| SW5 Refer to analog output selection switch (SW5) | |
| switch | |
| analog input selection switch (SW4)..... | 36 |
| analog output selection switch (SW5)..... | 36 |
| PNP/NPN mode selection switch (SW2)..... | 36 |
| Terminating Resistor selection switch (SW1)... | 36 |
| V1/T1 (PTC) mode selection switch (SW3) | 36 |
| Switches..... | 36 |

T

| | |
|---|-----------------|
| target frequency | |
| Cmd frequency..... | 397 |
| Temperature sensor fault trip..... | <i>NTC Open</i> |
| terminal | |
| A terminal..... | 139, 304 |
| B terminal..... | 139, 304 |
| terminal for frequency reference setting..... Refer to <i>VR terminal</i> | |
| terminal screw specifications | 579 |
| Terminating Resistor selection switch (SW1) | 36 |
| test run..... | 50 |
| Thermal Trip | 538 |
| TI terminal..... | 39, 97 |
| Time Event..... | 215 |
| time event scheduling..... | 215 |
| Exception Date..... | 215 |
| module types | 215 |
| parameters | 215 |
| RTC battery | 215 |
| RTC clock | 215 |
| Time Event..... | 215 |
| Time Period Module | 215 |
| Time Period Module..... | 215 |
| time scale setting..... | 112 |
| 0.01sec | 112 |
| 0.1sec..... | 112 |

| | |
|--|----------|
| 1sec | 112 |
| timer | 256 |
| protection features groupPRT (protection features) group | |
| TO terminal..... | 296 |
| torque..... | 26 |
| torque boost..... | 125 |
| auto torque boost..... | 126 |
| manual torque boost | 125 |
| overexcitation..... | 125 |
| trip | 536 |
| erasing trip history | 254 |
| fault/waring list | 339 |
| trip no motor trip..... | 332, 334 |
| trip status reset..... | 331 |
| troubleshooting | 541 |
| Trip mode..... | 59 |
| Trip mode..... | 493 |
| troubleshooting..... | 536 |
| fault trips | 541 |
| other faults..... | 544 |

U

| | |
|---------------------------------|----------------------------|
| U&M mode..... | 252, 351 |
| U/V/W terminals..... | 31, 32, 33, 34, 35, 544 |
| Under Load | |
| Under Load Trip..... | 328, 536 |
| Under Load Warning..... | 328, 540 |
| underload fault trip | 339 |
| underload warning..... | 340 |
| underload fault trip | Refer to <i>Under Load</i> |
| Unipolar..... | 39 |
| up-down operation..... | 150 |
| User & Macro mode..... | 58, 59, 61 |
| User group | 251 |
| delete parameters | 252 |
| parameter registration | 251 |
| User mode..... | 61 |
| user V/F pattern operation..... | 123 |
| User/Macro group | |

| | |
|-----------------------|-----|
| parameter group | 351 |
| U&M mode | 351 |
| using the keypad..... | 61 |

V

| | |
|--|--------|
| V/F control..... | 121 |
| linear V/F pattern operation | 121 |
| square reduction V/F pattern operation | 122 |
| user V/F pattern operation | 123 |
| V/F pattern configuration | 80 |
| V1 terminal..... | 38, 88 |
| V1/T1 (PTC) mode selection switch (SW3)..... | 36 |
| V2 | |
| analog input selection switch (SW4)..... | 39 |
| V2 input..... | 96 |
| I2 voltage input | 96 |
| Vacuum Pump (MC6) | 523 |
| variable torque load..... | 122 |
| vent cover | 12 |
| virtual multi-function input..... | 348 |

| | |
|--------------------------------------|----------------------|
| voltage/current output terminal..... | Refer to AO terminal |
| VR terminal..... | 38 |

W

| | |
|-------------------------------------|--------------------------------|
| warning | 339, 536 |
| fault/warning list | 339 |
| warning message | 540 |
| Warning..... | 340 |
| wiring..... | 14, 26 |
| circuit breaker..... | 575 |
| control terminal board wiring | 36 |
| copper cable | 26 |
| disassembling the cover | 27 |
| ferrite | 40 |
| ground | 28 |
| power terminal board | 29 |
| re-assembling the cover | 47 |
| wiring length | 40 |
| WM (write mode error)..... | 356 |
| Write parameter fault trip | Refer to <i>ParaWrite Trip</i> |



www.lselectric.co.kr

LS ELECTRIC Co., Ltd.

■ Headquarter

LS-ro 127(Hogye-dong) Dongan-gu, Anyang-si, Gyeonggi-Do, 14119, Korea

■ Seoul Office

LS Yongsan Tower, 92, Hangang-daero, Yongsan-gu, Seoul, 04386, Korea

Tel: 82-2-2034-4033, 4888, 4703 Fax: 82-2-2034-4588

E-mail: automation@lselectric.co.kr

■ Overseas Subsidiaries

• LS ELECTRIC Japan Co., Ltd. (Tokyo, Japan)

Tel: 81-3-6268-8241 E-Mail: jschuna@lselectric.biz

• LS ELECTRIC (Dalian) Co., Ltd. (Dalian, China)

Tel: 86-411-8730-6495 E-Mail: jiheo@lselectric.com.cn

• LS ELECTRIC (Wuxi) Co., Ltd. (Wuxi, China)

Tel: 86-510-6851-6666 E-Mail: sblee@lselectric.co.kr

• LS ELECTRIC Vietnam Co., Ltd.

Tel: 84-93-631-4099 E-Mail: jhchoi4@lselectric.biz (Hanoi)

Tel: 84-28-3823-7890 E-Mail: sjbaik@lselectric.biz (Hochiminh)

• LS ELECTRIC Middle East FZE (Dubai, U.A.E.)

Tel: 971-4-886-5360 E-Mail: salesme@lselectric.biz

• LS ELECTRIC Europe B.V. (Hoofddorf, Netherlands)

Tel: 31-20-654-1424 E-Mail: europartner@lselectric.biz

• LS ELECTRIC America Inc. (Chicago, USA)

Tel: 1-800-891-2941 E-Mail: sales.us@lselectricamerica.com

■ Overseas Branches

• LS ELECTRIC Tokyo Office (Japan)

Tel: 81-3-6268-8241 E-Mail: jschuna@lselectric.biz

• LS ELECTRIC Beijing Office (China)

Tel: 86-10-5095-1631 E-Mail: khpaek@lselectric.com.cn

• LS ELECTRIC Shanghai Office (China)

Tel: 86-21-5237-9977 E-Mail: tsjun@lselectric.com.cn

• LS ELECTRIC Guangzhou Office (China)

Tel: 86-20-3818-2883 E-Mail: chenxs@lselectric.com.cn

• LS ELECTRIC Chengdu Office (China)

Tel: 86-28-8670-3201 E-Mail: yangcf@lselectric.com.cn

• LS ELECTRIC Qingdao Office (China)

Tel: 86-532-8501-2065 E-Mail: wangzy@lselectric.com.cn

• LS ELECTRIC Nanjing Office (China)

Tel: 86-25-8467-0005 E-Mail: ylong@lselectric.com.cn

• LS ELECTRIC Bangkok Office (Thailand)

Tel: 66-90-950-9683 E-Mail: sjleet@lselectric.biz

• LS ELECTRIC Jakarta Office (Indonesia)

Tel: 62-21-2933-7614 E-Mail: dioh@lselectric.biz

• LS ELECTRIC Moscow Office (Russia)

Tel: 7-499-682-6130 E-Mail: jdpark1@lselectric.biz

• LS ELECTRIC America Western Office (Irvine, USA)

Tel: 1-949-333-3140 E-Mail: vwun@lselectricamerica.com

10310001336

Disclaimer of Liability

LS ELECTRIC has reviewed the information in this publication to ensure consistency with the hardware and software described. However, LS ELECTRIC cannot guarantee full consistency, nor be responsible for any damages or compensation, since variance cannot be precluded entirely. Please check again the version of this publication before you use the product.

© LS ELECTRIC Co., Ltd 2020 All Right Reserved.

LSLV-H100 / 2020.05

